



CLEARPATH-EC USER MANUAL

ETHERCAT COMPLIANT CLEARPATH MOTORS

DC INPUT, FRACTIONAL HORSEPOWER, IP67-RATED

NEMA 23 AND NEMA 34 FRAME SIZES

VERSION 1.18 / MARCH 27, 2026



THIS PAGE INTENTIONALLY LEFT BLANK

TABLE OF CONTENTS

TABLE OF CONTENTS	3
SAFETY WARNINGS	6
Personal Safety Warnings.....	6
Machine, Shock, and Fire Safety Compliance Warnings	6
General Disclaimer	7
INTRODUCTION	8
What is a ClearPath-EC Motor?	8
Parts of a ClearPath-EC Motor	10
TOP TIPS FOR CLEARPATH-EC USERS	11
QUICK START GUIDE	12
Read Me: User Warning	12
ClearPath Quick Setup.....	13
Required Items	13
Recommended Items.....	13
Secure Your Motor	13
Power Up Your ClearPath-EC Motor.....	14
Power-Up Procedure	16
Setting Up ClearView 3.0 Software	17
ClearView 3.0 Minimum System Requirements.....	17
Download and Install ClearView 3.0.....	17
Connecting a ClearPath-EC Motor to Your PC	18
Open ClearView 3.0 (Motor Setup Program).....	19
Test Spin Your Motors Using Motion Generator	20
If You See Exceptions, Warnings, or Motor Shutdowns.....	21
Auto-Tuning.....	21
Before You Seek Technical Help.....	22
CONNECTING TO AN ETHERCAT NETWORK	24
ClearPath-EC Connections Overview	24
EtherCAT Master	24
M12 Adapter (Teknic P/N: M12-ENET-CON)	25
INPUTS AND OUTPUTS	27
Overview: ClearPath-EC I/O Circuits.....	27
ClearPath-EC Inputs.....	29
Automatic Input Features.....	29
Input Current Draw	29
Input Wiring Examples	30
ClearPath-EC Outputs	32
Output Wiring Examples	33
Wiring An Axis Brake (Output B only).....	36
POWERING CLEARPATH-EC	37
Introduction.....	37
DC Bus Motor Power Supply (24-75VDC)	37
Logic Power Backup Supply (12-75VDC)	37
Before Powering a ClearPath.....	37
Power Distribution Boards	38
POWER4-HUB-S.....	38

POWER4-HUB-S System Diagram	39
POWER4-HUB-S Expanded System Diagram.....	39
POWER4-HUB-S: Things to Know	40
POWER4-STRIP-S.....	41
POWER4-STRIP-S: Things to Know.....	41
Other Power Supply Topics	43
The "Ideal" DC Bus Power Supply.....	43
Teknic IPC-3 and IPC-5.....	43
Underpowered DC Bus Motor Power Supplies	44
Switching Power Supplies.....	44
Power Supply Compliance Notes.....	44
Power Supply Switching and Fusing	45
FAQ: "What size DC Bus Motor Power Supply should I use?"	45
SOFTWARE (CLEARVIEW 3.0)	46
Minimum System Requirements.....	46
Installing ClearView 3.0 Software	46
ClearView 3.0 Software Tour.....	46
Manual Motor Controls	47
Dashboard.....	48
Soft Scope.....	49
ClearView 3.0 Menus	54
File Menu	54
Edit Menu	55
Setup Menu	56
Action Menu.....	58
Additional Features Menu	59
EtherCAT Parameters Menu	62
Access Menu.....	63
Using the Diagnostic Port.....	64
Terms Used in this Section	64
Connecting to the Motor Diagnostic Port	64
CLEARPATH-EC SOFTWARE REFERENCE	66
APPENDIX A: TROUBLESHOOTING	67
LED Blink Codes	67
APPENDIX B: MECHANICAL REFERENCE	68
Dimensioned Drawings (Links).....	68
Motors	68
Power Distribution Boards	68
Accessories	68
Motor Mounting Considerations.....	69
Connecting ClearPath to a Mechanical System.....	69
Motor Connection: General Tips and Guidelines.....	70
Notes on Coupling Selection.....	72
Installing Pulleys and Pinions	73
About End-of-Travel Stops	74
Hard Blocks.....	74
Elastomeric (rubber) Stops.....	74
Pneumatic (dashpots).....	74

End Stops and Hard Stop Homing.....	74
Fan Mounting (Optional)	75
APPENDIX C: CONNECTOR AND CABLE REFERENCE	76
Mating Connectors.....	76
Power4-Hub-S, Power4-Strip-S, IPC-5.....	76
M12 Adapter (P/N: M12-ENET-CON)	77
Cable Drawings (Links To Teknic.com)	78
APPENDIX D: SPECIFICATIONS.....	79
ClearPath-EC Motor: Common Specifications.....	79
POWER4-HUB-S	82
POWER4-STRIP-S.....	83
APPENDIX E: GROUNDING AND SHIELDING	84
Protective Earth (PE) Connection	84
Grounding and Shielding.....	84
Power Returns	85
APPENDIX F: CLEARPATH PART KEY.....	86
APPENDIX G: M12 ADAPTER SCHEMATIC.....	87
APPENDIX H: CABLES FOR CONTINUOUS-FLEX	
APPLICATIONS.....	88
Case 1: Motor I/O <i>Is Not</i> Used (simplest configuration)	88
Case 2: Motor I/O <i>Is</i> Used	89
EtherCAT Cabling Considerations	90
APPENDIX I: MISCELLANEOUS	91
How to make a Logic Power Supply cable for your POWER4- HUB-S	91
Other Product Notes.....	92
Re: Electrical Fast Transient (EFT) Testing.....	92
ClearPath EMC Instructions.....	92

SAFETY WARNINGS

IMPORTANT: Please read this safety information before attempting to install, apply power to, or operate a ClearPath motor. Failure to understand and follow the safety information presented in this document could result in property damage, bodily injury or death.

PERSONAL SAFETY WARNINGS

- Read and follow all safety information and warnings.
- Do not wear loose clothing or unconfined long hair when using ClearPath motors. Remove ties, rings, watches and other jewelry before operating an unguarded motor.
- Do not operate a ClearPath motor if your alertness, cognitive function, or motor skills are impaired.
- Always handle, and carry a ClearPath motor by the housing (don't carry it by the shaft or hanging from its cables).
- Be aware that in certain modes of operation ClearPath is designed to spin as soon as DC Bus Motor Power is applied.
- Install and test all emergency stop devices and controls before using ClearPath.
- Before applying DC power, secure the ClearPath motor to a sturdy work surface and install a finger-safe guard or barrier between the user and the motor shaft.
- Provide appropriate space around the ClearPath motor for ventilation and cable clearances.
- Do not allow cables or other loose items to drape over, or rest near the ClearPath motor shaft.
- Never place fingers, hands, or other body parts on or near a powered ClearPath motor.
- Thoroughly test all ClearPath applications at low speed to ensure the motor, controls, and safety equipment operate as expected.

MACHINE, SHOCK, AND FIRE SAFETY COMPLIANCE WARNINGS

- Do not open device enclosure. There are no user serviceable parts inside this product.
- Follow all instructions and use the product only as directed.
- Safety of any system incorporating this equipment is the responsibility of the system designers and builders.
- The machine designers need to recognize and incorporate required warning symbols, guards and shields for ClearPath motors that are used in applications that can result in the external accessible parts of their machine exceeding a temperature of 65 Celsius. This is required as a method to reduce burns. A tool shall be required to remove any guards and/or shields.

- ClearPath motors require that a conductive path exist between the motor chassis and the Protective Earth (PE) connection of the machine to which it is affixed. (Note: The PE connection is often satisfied by simply bolting the motor to the machine; however it is the users responsibility to verify the PE connection.) If an external grounding wire is required, use the same or larger wire gauge as used between the DC power supply and ClearPath Motor.
- Any maintenance or repair guide created by the user shall state that power shall be removed before the Protective Earth ground conductor is disconnected. When reconnecting power, the Protective Earth ground conductor shall be the first wire reconnected. Main power may be reconnected only after the Safety Ground connection is secure.

GENERAL DISCLAIMER

The User is responsible for determining the suitability of products for their different applications. The User must ensure that Teknic's products are installed and utilized in accordance with all local, state, federal and private governing bodies and meet all applicable health and safety standards.

Teknic has made all reasonable efforts to accurately present the information in the published documentation and shall not be responsible for any incorrect information which may result from oversights. Due to continuous product improvements, the product specifications as stated in the documentation are subject to change at any time and without notice. The User is responsible for consulting a representative of Teknic for detailed information and to determine any changes of information in the published documentation.

If Teknic's products are used in an application that is safety critical, the User must provide appropriate safety testing of the products, adequate safety devices, guarding, warning notices and machine-specific training to protect the operator from injury.

INTRODUCTION

WHAT IS A CLEARPATH-EC MOTOR?

ClearPath-EC is an all-in-one servo system consisting of a precision brushless servo motor (with encoder) combined with a powerful integrated servo drive, internal servo controller and EtherCAT interface, all contained in a housing that's about the size of a typical standalone servo motor. ClearPath-EC brings affordable, user-friendly, precision motion control to EtherCAT users.

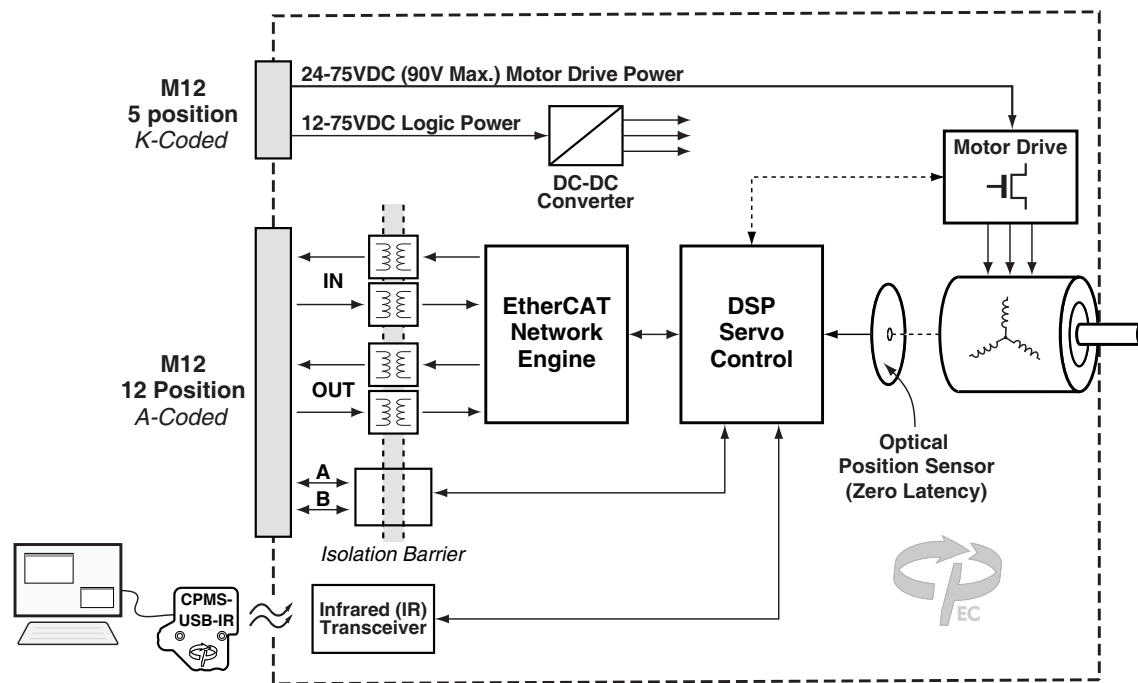

ClearPath-EC Block Diagram

ClearPath-EC is a professional level, industrial grade product.

The ClearPath-EC motor subsystem is based on Teknic's [Hudson family](#) of brushless servo motors, with the same oversized bearings, stainless steel shaft, high temperature windings, and powerful rare earth magnets.

The position sensing element is a high-resolution optical encoder with superior accuracy and ultra-low latency for improved servo response as compared to magnetic encoders. The servo drive electronics and motion control firmware employ the same state-of-the-art technology and advanced control algorithms as Teknic's high-end, non-integrated servo control products.

ClearPath-EC Simplicity begins with a quick, uncomplicated setup.

Install the included ClearView 3.0 software, connect ClearPath to your PC via USB, and configure and tune your ClearPath. Once setup is complete, disconnect ClearPath from your PC and start moving using your EtherCAT Master. ClearPath-EC includes two independently isolated I/O points that can be configured as general-purpose inputs or outputs and can be also configured for automatic functions, e.g., axis brake or touch probe.

ClearView 3.0 software is written in plain English with plenty of tips and annotations. Use ClearView 3.0 to tune your system, set parameters and options, and troubleshoot axis issues using the included Soft Scope.

Flexibility. ClearPath-EC motors support:

- Cyclic Synchronous Position (CSP)
- Cyclic Synchronous Velocity (CSV)
- Cyclic Synchronous Torque (CST)
- Profile Position (PP)
- Profile Velocity (PV)
- Profile Torque (TQ)
- Homing mode

ClearPath-EC motors are at home in applications ranging from variable speed conveyors to multi-axis positioning robots, to kinetic sculptures. And, while most ClearPath customers have a specific application in mind, it's reassuring to know that your ClearPath-EC can be reconfigured to perform a different job in just a few minutes.

Safety and self-protection features are standard. ClearPath will rapidly shut down if it becomes overloaded, overheated, detects a hard stop, or exceeds any of the safety or motion limits you specify.

Machine Safety features are standard. You have direct access to the motor drive power, so it's easy to implement Safe Torque Off (STO) by interrupting the ClearPath-EC's motor drive DC power. Only one interrupting circuit at a central point is required to render all ClearPath-EC motors in your machine safe, eliminating significant STO wiring. (ClearPath-EC's Logic Power input keeps EtherCAT communications, I/O and position feedback fully functional when ClearPath-EC's motor drive DC power is interrupted- so there is no loss of other functionality or information during a machine safety event.)

Absolute Position Feedback functionality is standard. Logic Power for a group of ClearPath-EC motors can be supplied by a battery and charger, preserving position information even during a power loss, lockout, or machine safety event.

Made in USA. Each ClearPath motor is built and tested in our New York manufacturing facility, so you can be certain you're getting a high quality, fully tested motion control product right out of the box. Additionally, Teknic backs up each ClearPath motor with a generous three-year warranty.

PARTS OF A CLEARPATH-EC MOTOR

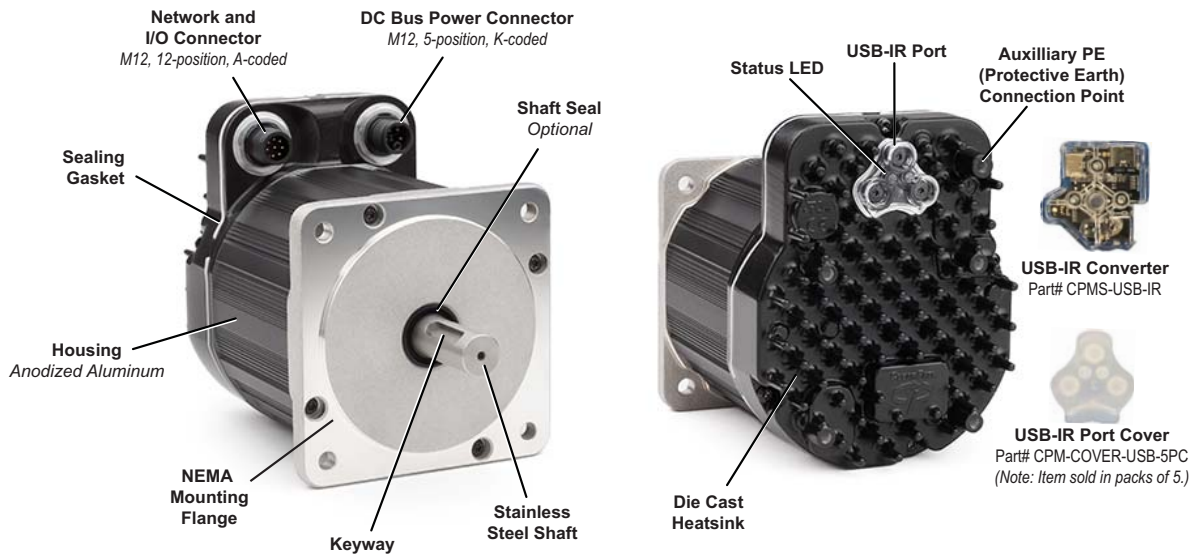

ClearPath-EC Motor

DC Power Connector - This M12, 5-position, K-coded connector takes in DC Bus Motor Power (24-75VDC) and Logic Power (12-75 VDC).

Network & I/O Connector - This M12, 12-position, A-coded connector provides access to the EtherCAT in and out ports and the two I/O circuits.

USB-IR Port - This is a watertight IR (infrared) communication port. It is used in conjunction with the USB-IR Converter to connect ClearPath to a Windows PC running ClearView 3.0.

USB-IR Converter - (Teknic part# CPMS-USB-IR) This device translates USB signals to and from high speed infrared light pulses facilitating communication between a ClearPath motor and a PC running ClearView 3.0 software. This device attaches magnetically to the ClearPath motor's USB-IR Port.

USB-IR Port Cover - (Teknic part# CPM-COVER-USB-5PC) Prevents accumulation of dirt and/or particulate on the USB-IR port when not in use. Sold in packs of 5. **Note: The USB-IR Port is waterproof with or without this cover installed.**

Status LED - Tri-color LED indicates the operational status of ClearPath device. See Appendix A for ClearPath LED codes.

Auxiliary PE (Protective Earth) Connection Point - Use is optional. Provides an alternative means of connecting the ClearPath motor to the machine's Protective Earth Terminal if the motor mounting bracket and/or plate is not properly bonded to PE. To use, connect a wire between this screw boss and a part of the machine frame/chassis that is bonded to machine PE.

TOP TIPS FOR CLEARPATH-EC USERS

These tips apply to the ClearPath-EC, IP66K/IP67 rated motors discussed in this document.

TOP TIPS

- ✓ **Avoid Right-Angle M12 Cable Connectors!** Teknic *strongly* discourages the use of right-angle M12 connectors with your ClearPath-EC motors because even a relatively small lever force applied to a right angle M12 connector can cause irreparable damage to the motor's on-body connectors.
- ✓ **Tightening M12 Connectors.** For a reliable seal, tighten the M12 communication and power cables between 0.8Nm-1.4Nm. **Tip:** When M12 cable connectors are properly tightened, there should be no more than 1-2 threads visible on the motor connectors.
- ✓ **Remove DC Bus Power** whenever connecting/disconnecting a power cable from your motor's power connector. Removing power will prevent electrical arcing from damaging the motor pins and cable contacts over time.
- ✓ **Small Noise at Power Up?** Your ClearPath motor will make a brief (<1 sec.) buzzing sound upon first power up as the motor initializes itself. This is normal and necessary.
- ✓ **Motor Killer!** Never reverse DC Bus Motor Power polarity (positive vs. negative) to your ClearPath motor. Doing so will irreparably damage the motor.
- ✓ **USB Cables.** If you are having USB communication problems, verify that you are using a **USB-IF certified cable** to communicate with your ClearPath-EC motor. [Teknic USB cables](#) are USB-IF certified. Need [more information?](#)
- ✓ **Cover Your Motor's USB-IR Port** when not in use. This will help prevent IR communication issues caused by dust and debris buildup on the IR port.
- ✓ **Auto-Tune Your Motor Fully Loaded.** Always run Auto-Tune with your ClearPath-EC motor coupled to the mechanical system, exactly as it will run during normal machine operation. **Note:** *The default motor tuning file that comes with your motor is designed for no-load operation.*
- ✓ **Don't Operate Under Water.** The sealed ClearPath complies with the IP66K/IP67 rating but is not designed to be operated submerged.

QUICK START GUIDE

This section was designed to help you get your ClearPath-EC motor up and running quickly and safely.

IN THIS SECTION

- Downloading and installing *ClearView 3.0* (setup and configuration software)
- How to power up your ClearPath-EC motor
- How to connect your ClearPath-EC to a PC and establish communication
- How to spin your unloaded¹ ClearPath motor under ClearView 3.0 software control

READ ME: USER WARNING

Always use caution and common sense when handling motion control equipment. Even the smallest ClearPath motor is powerful enough to seriously damage fingers, turn a tie into a noose, or tear out a patch of hair and/or scalp in just a few milliseconds (by comparison, it takes between 100 and 400 milliseconds to blink). We're not trying to scare you (...OK maybe a *little*) but we do want all ClearPath users to stay safe and *fully intact*. **These devices are very powerful and can be extremely dangerous if used carelessly.** Please read and understand all safety warnings in the ClearPath User Manual before operating a ClearPath motor.

¹ Unloaded means *with nothing attached to the motor shaft*. ClearPath comes factory preconfigured for unloaded operation. **ClearPath must be tuned** whenever it is connected to a new type of mechanical system.

CLEARPATH QUICK SETUP

REQUIRED ITEMS

- Windows PC (Win 10, 11) with ClearView 3.0
- ClearPath-EC motor
- DC Bus Motor Power Supply (with cables) 24-75 VDC
- Power distribution board (POWER4-HUB-S or POWER4-STRIP-S)
- Logic Power Backup Supply (12-75VDC). *Required only if using Power4-HUB-S.*
- USB-IR Converter (Teknic PN CPMS-USB-IR)
- USB A-C data cable, Teknic PN: CPM-CABLE-USB-118AC

RECOMMENDED ITEMS

- M12 Adapter, P/N M12-ENET-CON
- Network & I/O cables

SECURE YOUR MOTOR

Injury Warning: Your motor may buck and jump during tuning and operation. To prevent injuries and property damage, **please secure your ClearPath motor to a stable work surface** before operating it.

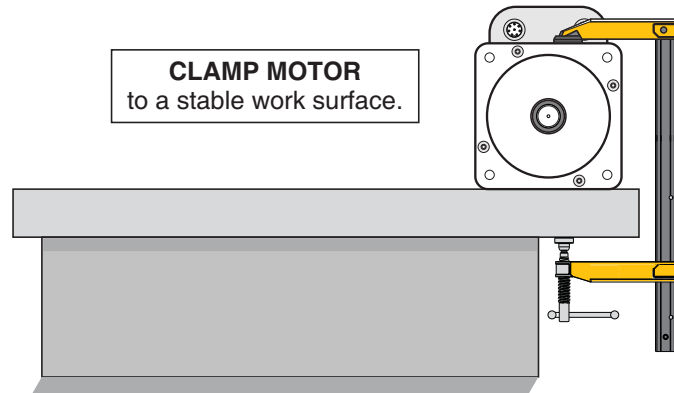

Clamp it!

POWER UP YOUR CLEARPATH-EC MOTOR

THINGS YOU'LL NEED

- DC Bus Motor Power Supply: Teknic/IPC-5, 75VDC Bus Motor Power Supply or equivalent, cables as shown below.
- Power distribution board: POWER4-HUB-S or POWER4-STRIP-S. **Note:** for POWER4-HUB-S users, a separate Logic Supply is required (12-75VDC). A separate Logic Supply *is not* required when using a POWER4-STRIP-S.
- Cables as shown below.

Tightening M12 connectors. For a reliable seal, tighten the communication and power cables between 0.8 Nm-1.4 Nm. **Tip:** When M12 cable connectors are properly tightened there should be no more than 1-2 threads visible on the motor connectors.

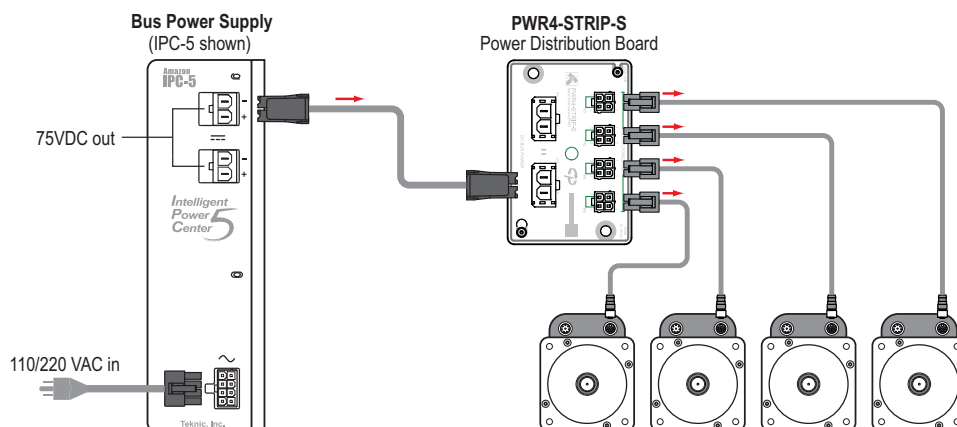
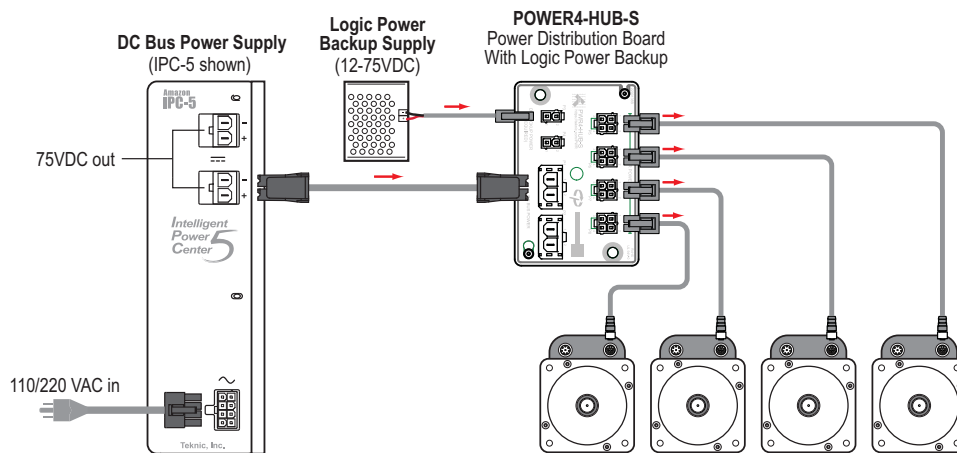

ClearPath-EC Power Connections using a POWER4-HUB-S or POWER4-STRIP-S

TEST DC POWER POLARITY

IMPORTANT: Reversing DC Bus Power polarity *will* permanently damage your ClearPath motor.

Important Notes

- If using Teknic manufactured cables, you can safely skip this test.
 - **Do not force or jam DMM probes into the connector.** Use smaller probe tips or find a safe alternative way to verify that polarity is correct.
1. Start with the 5-position power connector disconnected from your ClearPath-EC motor and the AC unplugged.
 2. Power-up your DC Bus Motor Power Supply.
 3. **Measure DC Bus Motor Power Supply voltage and polarity.** With a multimeter, measure the DC voltage from Bus Motor Power+ (positive) to Bus Motor Power- (negative).
 4. Power-up your logic power supply.
 5. **Measure Logic Supply voltage and polarity.** With a DMM, carefully measure the Logic Supply voltage between Logic Power+ and Logic Power.

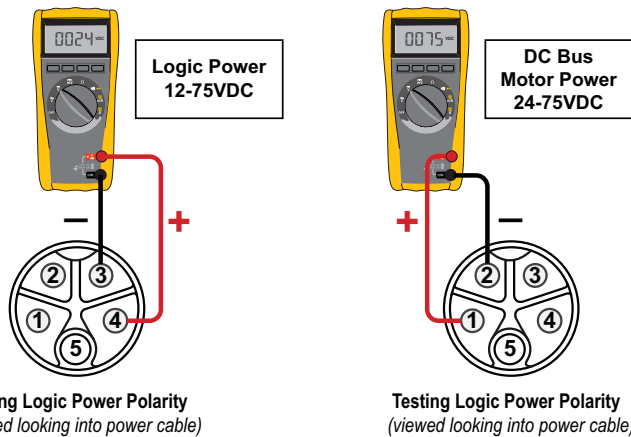

Terminal Assignment Table			
Position	Wire Size	Color	Signal
1	16 AWG	Red	Bus Motor Power +
2	16 AWG	Black	Bus Motor Power -
3	22 AWG	Blue	Logic Power -
4	22 AWG	Orange	Logic Power +
5	N.C.	-	N.C.

Check power polarity with a DMM

Note: See [Appendix C](#) for links to cable drawings and pinouts.

POWER-UP PROCEDURE

1. **IMPORTANT:** Start with power supplies turned off. See note below.
2. Connect cables as shown earlier in this section.
3. Turn on power supplies.

IMPORTANT: Remove DC Bus Power whenever connecting or disconnecting a power cable from your motor's M12 power connector. Removing power will prevent electrical arcing from damaging the motor and connector terminals.

SETTING UP CLEARVIEW 3.0 SOFTWARE

ClearView 3.0 diagnostic and configuration software consists of a suite of powerful tools, including:

- **Auto-Tune** - Easily tune your ClearPath-EC motor using this built in utility.
- **Soft Scope** - View multiple system variables on an oscilloscope-like display. such as measured torque, velocity, following error, and many more.
- View and manage alerts, exceptions, and warnings in real time.
- **Move Generator** - Command motion, even prior to having Master or an EtherCAT network up and running. The built-in Move Generator software features a simple, intuitive set of controls that let you easily jog your motors, make positioning moves, torque moves, and velocity moves with a bare minimum of components.

CLEARVIEW 3.0 MINIMUM SYSTEM REQUIREMENTS

Operating system:	Win 10, 11
Processor:	1 GHz or faster
RAM:	2 GB
Free hard drive space:	550 MB
Monitor:	1280 x 1024 pixels or higher

DOWNLOAD AND INSTALL CLEARVIEW 3.0

1. Download the ClearView 3.0 installer from:
<https://www.teknic.com/downloads/>.
2. Launch the ClearView 3.0 installer. Follow the on-screen prompts to complete installation.

Note: ClearPath-EC motors are compatible with ClearView 3.0 or later.

CONNECTING A CLEARPATH-EC MOTOR TO YOUR PC

1. Power up your ClearPath-EC motor.
2. Connect a high-quality USB cable (A to C or C to C) to the USB-IR Converter (CPMS-USB-IR) and magnetically attach it to the motor's IR communication port. See figure below ².
3. If this is a first-time connection, wait for ClearPath to automatically install its driver software before proceeding. This should only take a few seconds.

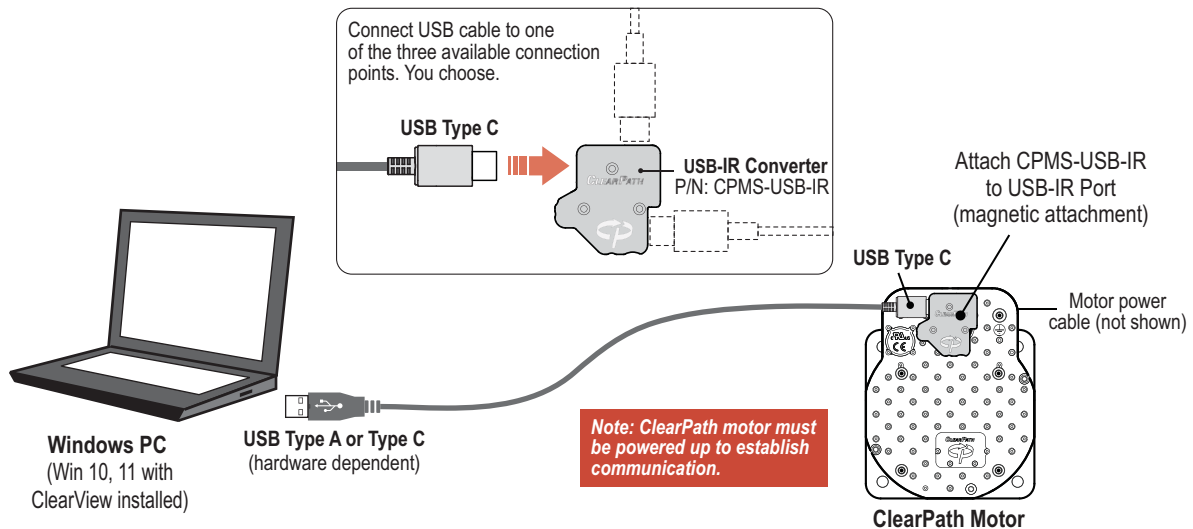

Connect ClearPath to your PC

Important Communication Notes

- For best performance use USB-IF certified cables such as Teknic's [CPM-CABLE-USB-118AC](#). Avoid using USB cables of unknown origin (i.e. found in junk drawer). Cables designed for charging only will not work with this product.
- You may connect your ClearPath to a PC at any time to use ClearView 3.0 configuration and diagnostic software tools.
- ClearPath does not require a USB to PC connection during normal machine operation.

² The diagnostic communication scheme allows all ClearPath-EC motors to be sealed to IP67/66K without having to depend on sealing from auxiliary covers when not in use. NOTE: The CPMS-USB-IR adapter is not sealed and should not be left installed in wet environments.

OPEN CLEARVIEW 3.0 (MOTOR SETUP PROGRAM)

After you open ClearView 3.0, your ClearPath-EC motor will attempt to establish communication with your PC. When successfully connected, the ClearView 3.0 UI will look similar to that of the figure shown below.

MAIN UI FEATURES

- Enable/Disable button
- Clear Exceptions button
- E-Stop button (or Esc key on keyboard)
- Torque Limit Setup
- Move Generator (allows you to command several different move types).
- Jog Motion Controls allow you to manually jog the motor.
- EtherCAT Connection Status
- Motor Status

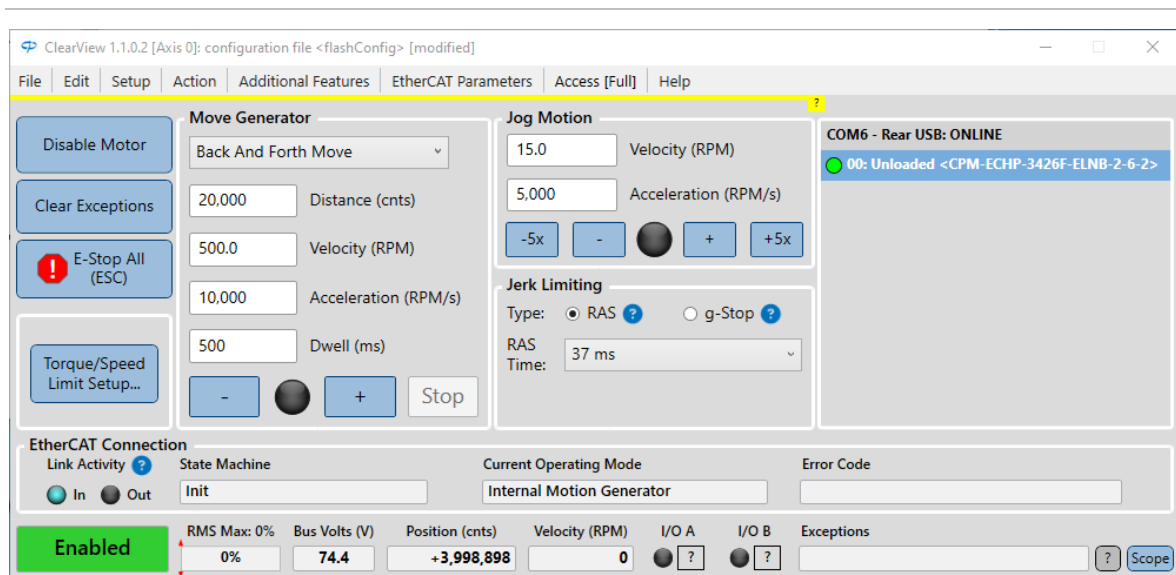

ClearView 3.0 motor setup and configuration software

TEST SPIN YOUR MOTORS USING MOTION GENERATOR

Note: This section describes how to spin an unloaded motor (i.e. a motor with nothing attached to the shaft). Important: ClearPath-EC motors ship out pre-configured for unloaded use only. You must run the Auto-Tune application whenever you connect your motor to a different mechanical system.

Click and spin—no Master required! Once your system is powered up and communicating, you can take your motors for a test spin using ClearView's Move Generator or Jog Motion controls. Refer to instructions below.

Important: To change settings and run moves you must set ClearView to **Full Access mode** using the "Access" dropdown menu.

1. Select the motor you'd like to spin from the Motor List.
2. Set the Move Type: Back and Forth, Single, Repeating, or Constant Velocity.
3. Enter the Move Parameters: Distance, Velocity, Acceleration, and Dwell (Dwell is just the pause time between repeating moves).
4. Click Enable/Disable button to enable the motor.
5. Click "+" to start in the CCW direction. Click "-" to start in the CW direction.
6. Single click the "Stop" button to end motion cycling. Double click the Stop button to stop motion immediately.
7. Click "E-Stop All" or hit your Esc key to stop motion immediately.

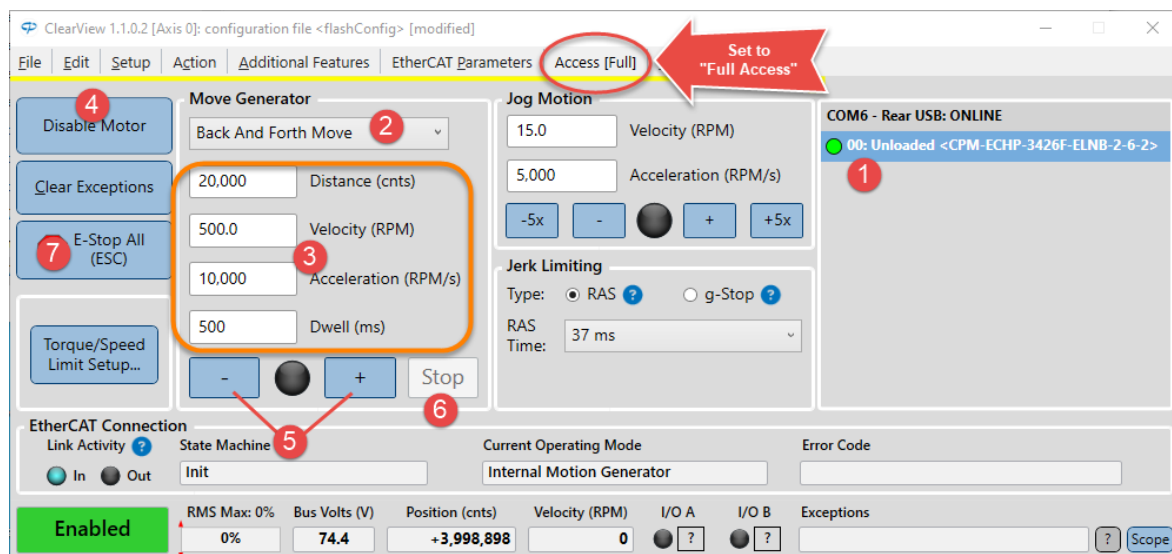

ClearView 3.0 UI

IF YOU SEE EXCEPTIONS, WARNINGS, OR MOTOR SHUTDOWNS

If your motor shuts down while running unloaded, check the Exceptions field in ClearView 3.0 for information and troubleshooting suggestions.

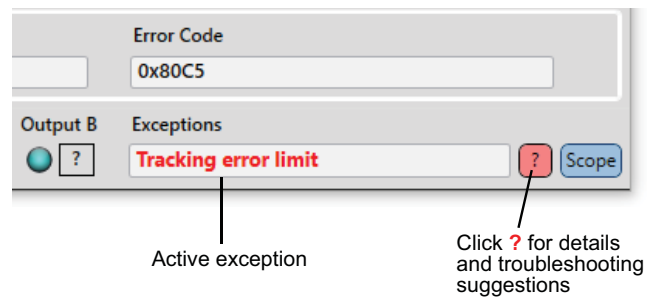

Exception information displayed in ClearView 3.0 UI

- Many shutdowns are caused by non-motor issues such as an undersized power supply, mechanical problems, and/or inappropriate move settings. A shutdown does not automatically mean that the motor is broken.
- If you get Torque Sat, Volt Sat, or Over Speed exceptions, try reducing move acceleration, velocity, or both to see if the exception clears.
- Clear most exceptions by clicking the Clear Exceptions button, but be aware that if the underlying problem isn't fixed, shutdowns may continue to occur.
- IF THE MOTOR'S STATUS LED FLASHES **RED**, your ClearPath motor has identified an internal hardware problem and may need to be returned for repair or replacement. Please contact Teknic if this happens.

AUTO-TUNING

Tuning is required whenever you bolt a ClearPath motor to a new or different mechanical system. The Auto-Tune feature speeds up and simplifies the tuning process in most cases.

BEFORE YOU BEGIN THE AUTO-TUNE PROCESS:

- Disable your motor.
- Recommended: Turn off your PC's sleep mode. If your PC goes into standby, sleep, or hibernation mode during Auto-Tune, the process will fail.
- Tighten all couplings, fasteners, pinions, and belts to the manufacturer's specifications.
- Make sure the axis and machine frame is fully intact.
- Don't try to tune a system on casters or on a flimsy table.
- Use a power supply designed for use with servo motor drives such as Teknic's IPC-3 or IPC-5 series.
- Don't use a low power switching power supply.

STARTING THE AUTO-TUNER

In ClearView 3.0, click **Setup>Tuning>Auto-Tune**.

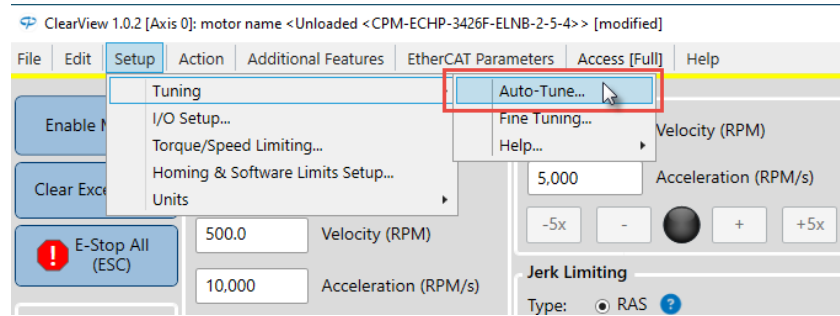

Start the Auto-Tuner

Important: The Auto-Tune application was designed to walk the user through the tuning process in a safe, step-by-step manner. Anyone engaged in Auto-Tuning must be able to read and follow all instructions presented.

DURING THE AUTO-TUNE PROCESS

- **Be careful.** Immobilize your motor with a clamp or vise. Keep your hands, hair and clothing away from the motor shaft and mechanical system.
- **Be patient.** Auto-Tune will take several minutes (5-15 minutes is typical).
- **Be calm.** Expect to hear humming, buzzing, clicks and clacks. Loud squeals and buzzes are perfectly normal while ClearPath explores the limits of your mechanical system.

BEFORE YOU SEEK TECHNICAL HELP

Issue: The status LED on the motor is not lit, and my ClearPath apparently has no power.

- Connect power cable to ClearPath.
- Plug in and turn on power supply.
- Verify wall outlet is powered and no circuit breakers are tripped.
- If you accidentally reversed DC power to your ClearPath motor, it may be damaged and in need of repair or replacement.

Issue: The status LED is working, but my ClearPath and PC are not communicating.

- Disconnect the USB cable from ClearPath and your PC, close ClearView 3.0, restart, and reconnect the USB cable.

Issue: Auto-Tune failed to complete.

- Verify that the motor is sized appropriately for the application. Don't expect a tiny, NEMA 23 motor with no gearing to spin a manhole cover.
- If your power supply is a switcher or an underpowered “bulk” linear supply with insufficient current and/or capacitance, and cannot tolerate regenerated energy, you'll have problems running Auto-Tune. ClearPath motors can operate between 24-75 VDC, but they require adequate power to complete an Auto-Tune.

Issue: My ClearPath is getting shutdowns.

- A shutdown does not automatically mean that the motor is broken or defective.
- Shutdowns with yellow or green blink codes usually mean that ClearPath is reporting a problem but is unlikely to be the source of the problem. Connect ClearPath to your PC running ClearView 3.0 and look in the “Exceptions” field to see what's being reported.
- Check the ClearPath User Manual (Appendix A) for blink code details and suggested fixes.
- If you see a shutdown accompanied by a red flashing LED, you'll probably have to return your ClearPath for repair or replacement. Check the Teknic website for repair/return information.

How do I restore my ClearPath to its factory default settings?

If you need to return ClearPath to its original state (i.e., configured exactly as it was when we shipped it to you), use File>Reset Config File To Factory Defaults. All parameters and settings will be over-written and ClearPath will be returned to its default factory configuration.

CONNECTING TO AN ETHERCAT NETWORK

This section discusses how ClearPath-EC motors can be integrated into your EtherCAT machine topology.

The ClearPath-EC system:

- Features the same compact motor size as other ClearPath models
- Works with standard, off-the-shelf network patch cables (CAT 5 or higher)
- Uses a single, low cost motor-to-M12 Adapter cable (one per motor) available from Teknic in 39", 144" and 315" lengths

CLEARPATH-EC CONNECTIONS OVERVIEW

ClearPath-EC components easily connect to EtherCAT compliant systems.

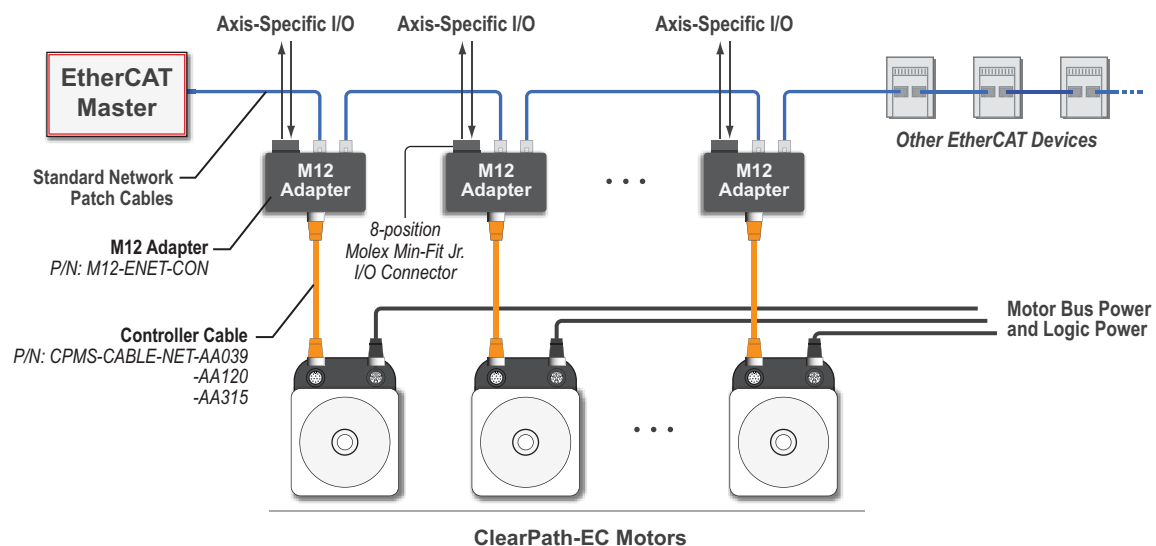

ClearPath-EC EtherCAT system overview

ETHERCAT MASTER

All EtherCAT Masters that support the CiA® 402 device profiles should be compatible with ClearPath-EC motors.

IMPORTANT: It is the user's responsibility to ensure that the Network Interface Card (NIC) in their Master uses an EtherCAT compatible chipset.

M12 ADAPTER (TEKNIC P/N: M12-ENET-CON)

Each ClearPath-EC motor must be paired with an M12 Adapter. M12 Adapters can be mounted wherever it makes sense to route EtherCAT network cables and ClearPath-EC motors. See [Appendix G](#) for a schematic drawing of the M12 Adapter.

M12 Adapter features

- Provides access to EtherCAT network signals via standard network patch cables (CAT-5 and above).
- Provides access to the motor's I/O signals via a Molex Mini-Fit Jr. 8-position connector.
- Supports IP67/66K ingress protection when mounted as directed.
- Low-cost, passive component device.



ClearPath-EC M12 Adapter (P/N: M12-ENET-CON)

The M12 Adapter includes multi-point sealing features as shown below. It can be easily mounted through a bulkhead wall such that IP67/66K compliance is maintained.



M12 Adapter sealing features for mounting to a sealed bulkhead

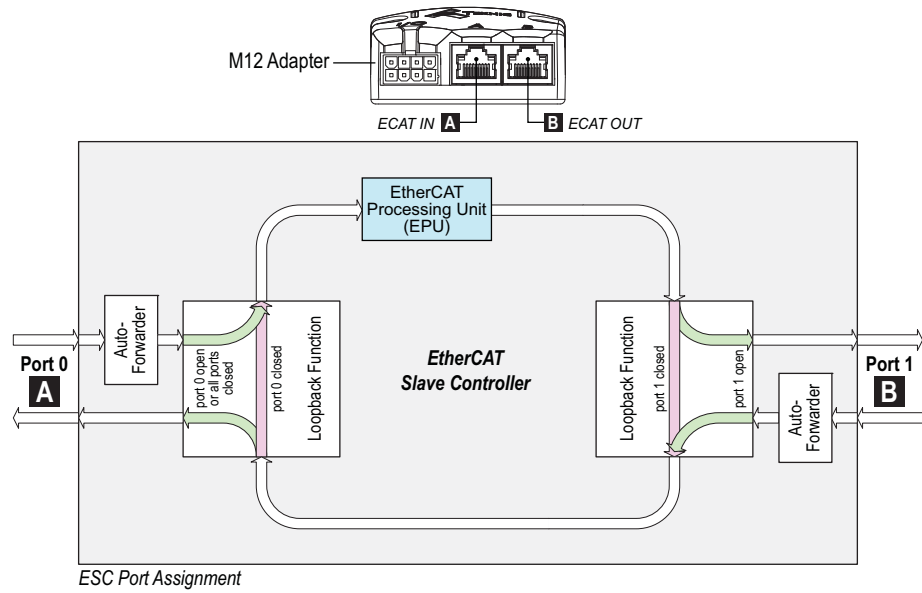

M12 Adapter: EtherCAT Port Topology

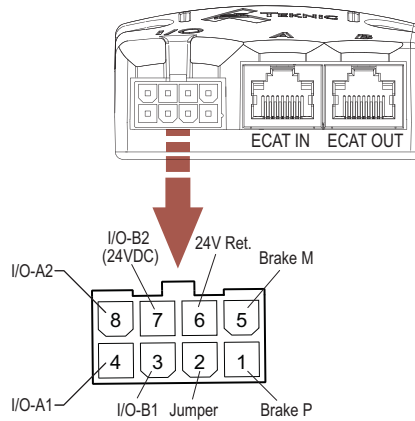

M12 Adapter: I/O Connector

M12 Adapter Schematics

This document includes a schematic of the M12 Adapter in [Appendix G](#) for general reference, *and* for customers who would like to port the functionality of the M12 Adapter into their own custom device. As an example, a machine builder might consider designing a multi-axis version of the M12 Adapter, or adding their own customized I/O functionality.

INPUTS AND OUTPUTS

OVERVIEW: CLEARPATH-EC I/O CIRCUITS

ClearPath-EC motors include two fully-protected, fully-isolated, high-speed digital I/O circuits for connecting sensors, actuators, and logic level devices. These circuits are referred to as **I/O-A** and **I/O-B** in this document.

The I/O signals are routed from the M12 Adapter to the motor by means of a controller cable. The I/O-A and I/O-B circuits are accessible via a Molex MiniFit Jr. 8-pin connector on the M12 Adapter.

- Each of the I/O circuits can be configured as *either* an input or an output.
- **I/O-B only** can be configured as an output to control a typical 24VDC, power-off motor brake. For brake wiring details, see the section [WIRING AN AXIS BRAKE \(Output B Only\)](#) later in this section.

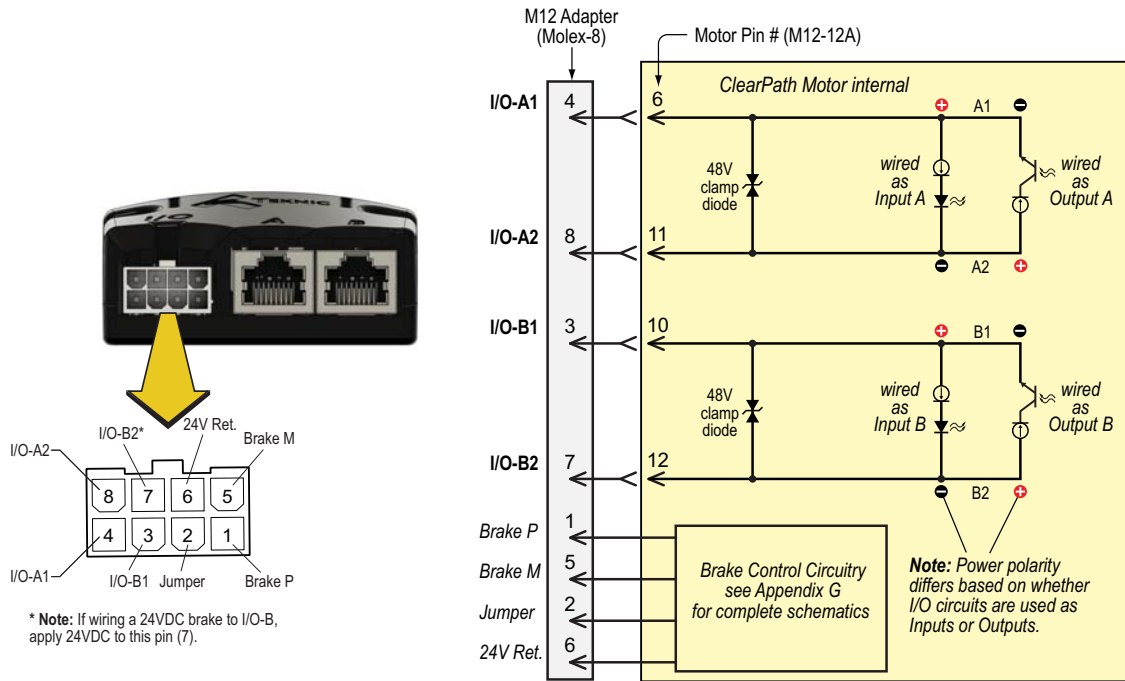

The polarity of I/O circuit power depends on whether the circuit is used as an input or as an output. For example, in the figure above, if I/O-A is used as an *input*, the user would apply power such that pin 4 is (+) and pin 8 is (-). Conversely, if I/O-A is used as an *output* the applied power polarity would be pin 8 (+) and pin 4 (-). The I/O wiring examples later in this section will show this more clearly.

This configuration allows the input and output circuits to be robustly protected while minimizing interference from parasitic circuit elements. Current is limited in both input and output configurations for protection and to eliminate the need for external resistors. Both the input and output circuits operate from 5V logic levels up to 24V industrial circuit levels.

In addition, the I/O circuits are optically isolated from the internal processor *and from each other*. This allows these A and B circuits to sink or source current as outputs, and independently be driven from sinking or sourcing devices when used as inputs.

You may also note that each I/O circuit is protected by a **48V bi-directional clamp diode** to protect against inductive kickback from connected coils (relays, contactors, solenoid valves, etc.)

IMPORTANT: The motor cable connectors must be properly tightened to maintain IP67 (waterproof) rating. Failure to tighten these connectors may result in motor damage due to water ingress. Tighten until 1-2 threads are visible on the motor's M12 connectors.

CLEARPATH-EC INPUTS

When I/O-A or I/O-B are configured as inputs, they support a wide range of input devices including simple toggle switches, limit/home sensors, relays, PLC outputs, microcontroller outputs, and more.

The state of Input A and Input B can be read by the EtherCAT Master. As such, the A and B inputs can be used by the EtherCAT Master to read sensors or digital logic signals.

AUTOMATIC INPUT FEATURES

In addition to adding I/O to the Master, there are a few fixed functions within the ClearPath-EC motor that the inputs can trigger automatically:

1. **Limit.** Use as a limit input can stop the motion in a programmed direction. One, two, or no limit inputs can be used.
2. **Home Registration.** This is used to monitor a switch to register the axis during a homing operation. The axis is then brought to a defined point relative to the switch. Home registration use can be mixed with limit switch use for a linear axis.
3. **Touch Probe.** Input A can be configured to perform a high-speed position capture of the internal encoder signal (for use with a touch probe or other trigger sensor). The captured value is stored and can be read by the EtherCAT Master for use in calibration, on-the-fly registration, etc.
4. **Interlock.** This will disable the servo when triggered. It is not safety rated.

INPUT CURRENT DRAW

See table and graph for minimum input current required for ClearPath input circuits over the range of acceptable input voltages.

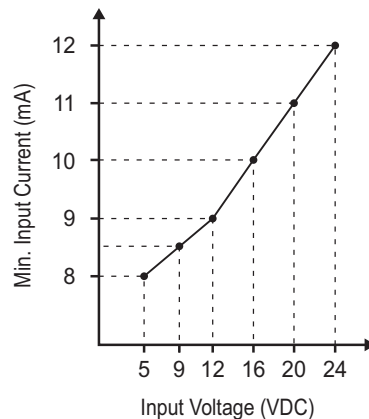

Voltage at ClearPath Input	Minimum Input Current Required*
5 VDC	8 mA
12 VDC	9 mA
24 VDC	12 mA

*To guarantee reliable input operation, the supply used with your ClearPath inputs should be capable of sourcing *at least* the above stated current at the associated voltage for each input used.

Maximum input current for given input voltages

DAMAGE WARNING: CLEARPATH INPUTS

ClearPath-EC inputs are robust, but there are some situations where they can be damaged. For example, connecting 75VDC bus power across an input will kill it.

INPUT WIRING EXAMPLES

Input A, and *Input B*, are designed for use with 5-24VDC logic levels and pulses from a wide variety of signal sources and devices including PLCs, microcontrollers, and mechanical switches.

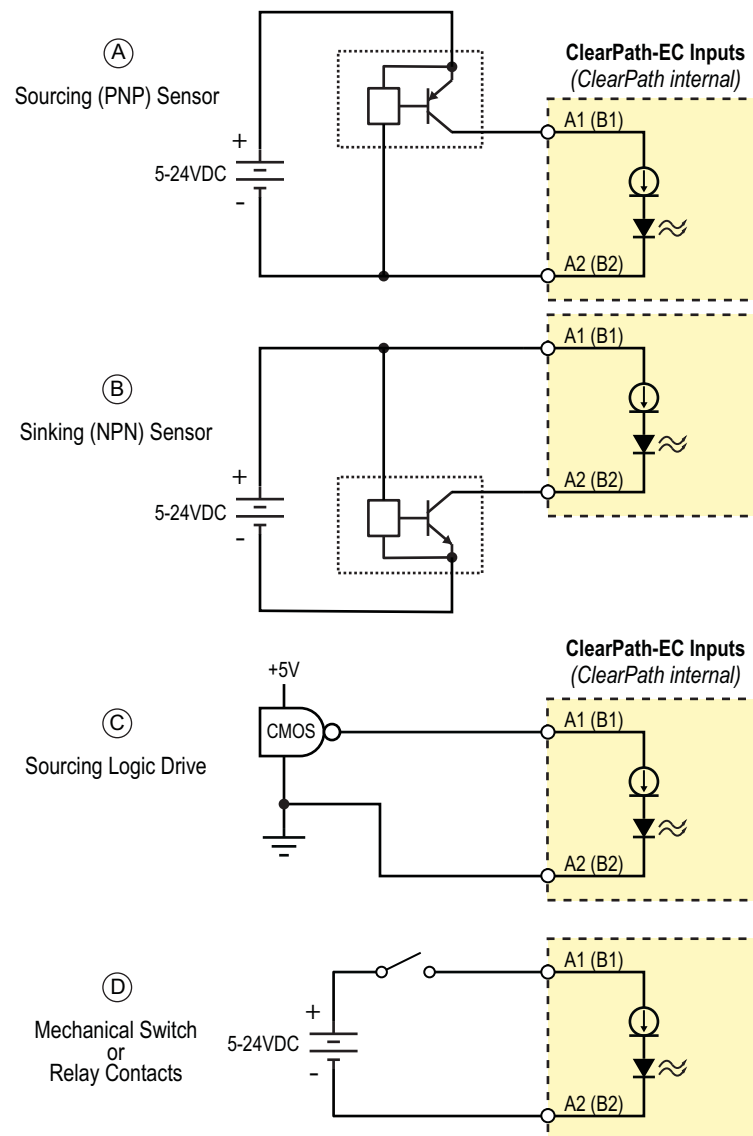

ClearPath Input Wiring

ClearPath inputs are compatible with many standard devices including: A) open-collector sourcing transistor B) open-collector sinking transistor, C) 5V CMOS logic, D) Mechanical switches or relay contacts.

The examples shown above are not exhaustive. The inputs can be controlled from any sinking or sourcing device or totem-pole driven outputs in the 4V to 24V range including outputs from PLCs, sensors, signal generators, microcontrollers and more as long as the connected device can supply the minimum current.

Note: 5V differential outputs are not directly compatible with ClearPath inputs. This is because the output voltage swing of a differential driver is not guaranteed to meet the ClearPath's 4V minimum input voltage requirement.

While differential drivers may work initially, they may fail over time as the environment changes, i.e. the motor heats up, components age, and so forth. This can result in erratic operation that is difficult to debug.

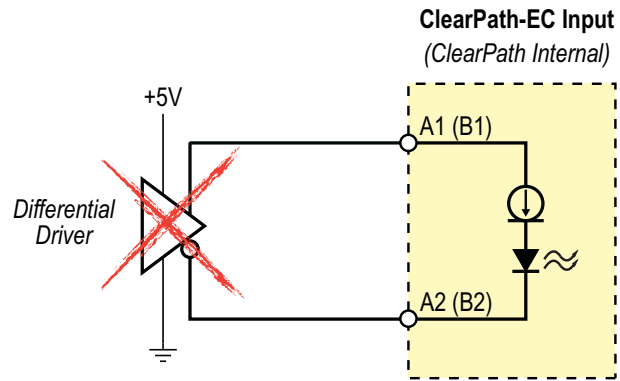

5V differential outputs are not supported

CLEARPATH-EC OUTPUTS

When I/O-A or I/O-B are configured as outputs, they support a wide range of devices including relay coils, logic inputs, LEDs, etc.

Output Notes

- **Output B** can be wired to control a power-off brake. *Output A cannot be used for brake control.*
- Outputs can be turned on and off by the EtherCAT Master.

Note: When used as outputs, the I/O-A and I/O-B circuits are not internally powered, therefore an external power supply is required. The external supply should be 5-24VDC and capable of sourcing/sinking at least 1mA, non-inductive. External power is generally supplied by a PLC, control board, or separate dedicated supply. See Appendix D for complete specifications.

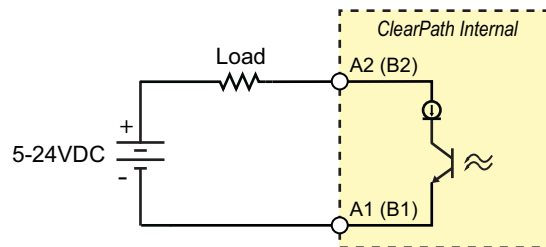

A or B output circuit driving a resistive load

OUTPUT WIRING EXAMPLES

Any external circuit or device to be connected to the ClearPath output should conform to the guidelines below. Proper circuit design/selection greatly reduces the probability of electrically damaging the output, particularly in the event of a common production mistake such as an accidental short or reversed wiring.

SINKING OUTPUTS

Outputs can be used as a sinking output as shown below. This topology provides ClearPath with a high level of immunity from damage if, for example, the circuit is shorted to machine chassis. Such a short would simply make the output appear like a closed circuit.

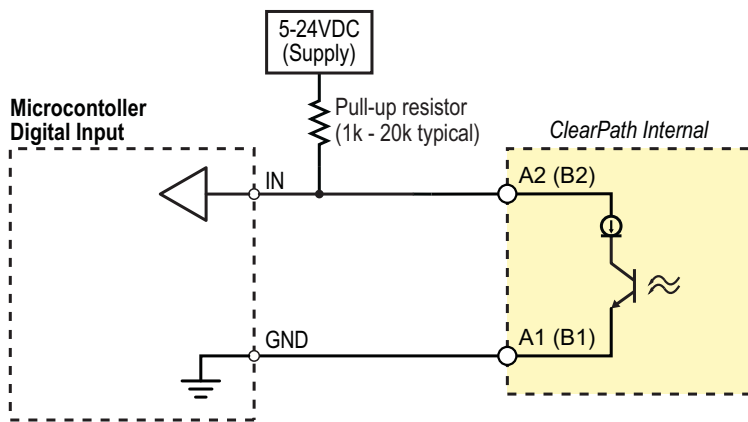
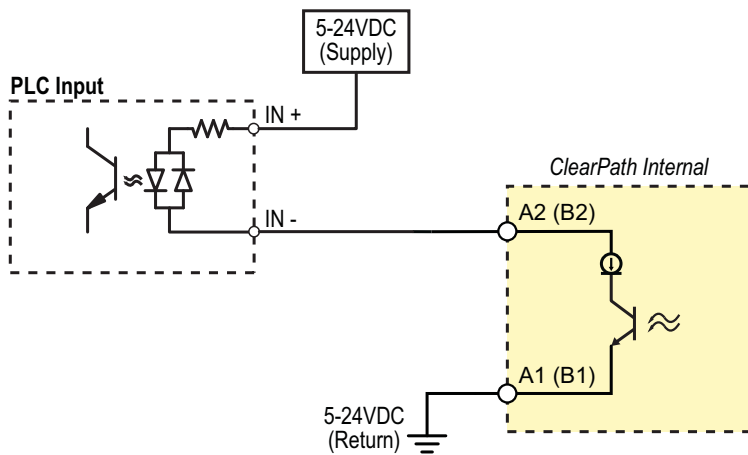

Sinking output examples

SOURCING OUTPUT

A or B can be used as a sourcing switch as shown below.

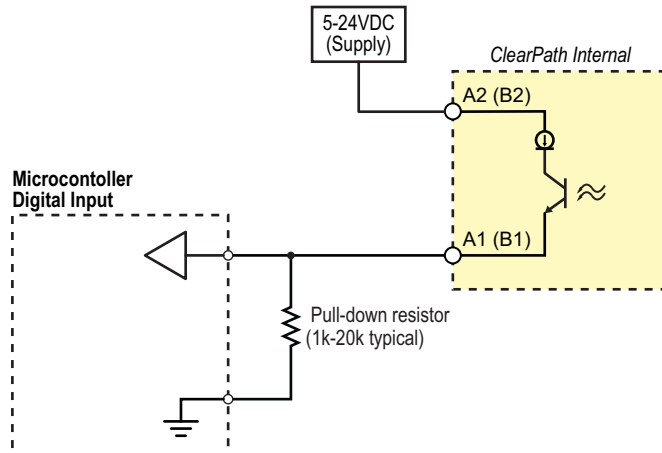
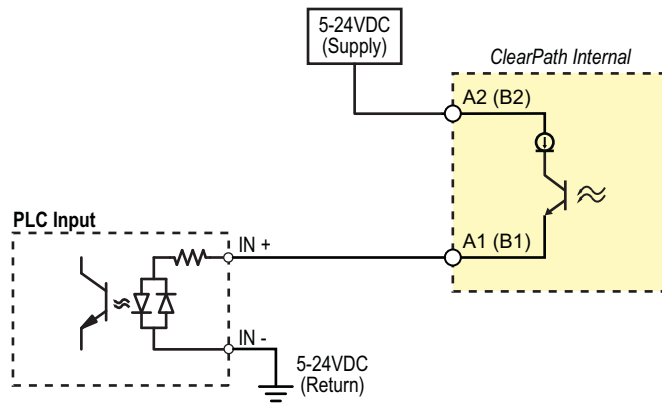

Sourcing output examples

Tips on microcontroller inputs

- Check your microcontroller documentation to see if the inputs already have internal pull-up resistors before adding an external pull-up. If a pull-up/pull-down is too large $>10,000 \Omega$, an additional lower value resistor may be required to minimize noise ingress.

OUTPUT APPLICATION EXAMPLES

Driving an LED

The output circuits are not internally powered; they require an external 5–24VDC power supply capable of supplying at least 10mA. In typical output use, power is supplied by the PLC, control board, or an external supply. See Appendix D for complete specifications.

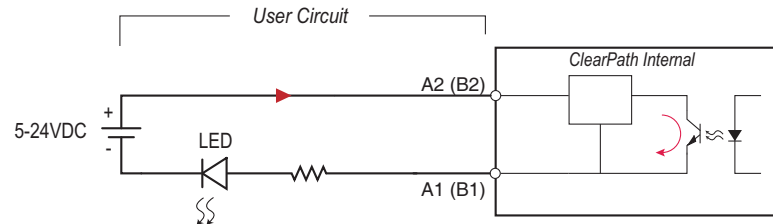

WIRING AN AXIS BRAKE (OUTPUT B ONLY)

The Network Adapter includes a built-in protected circuit designed to drive an axis brake directly. Brakes are commonly used on vertical axes, sprung axes, or axes that must be locked in position during a safety shutdown or other disabling event.

I/O-B (configured as an output) can be wired for brake control as shown in the diagram below:

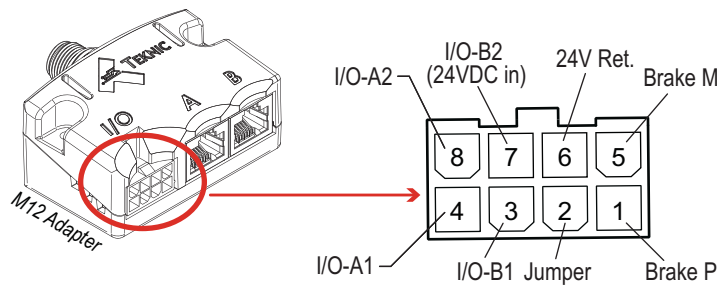
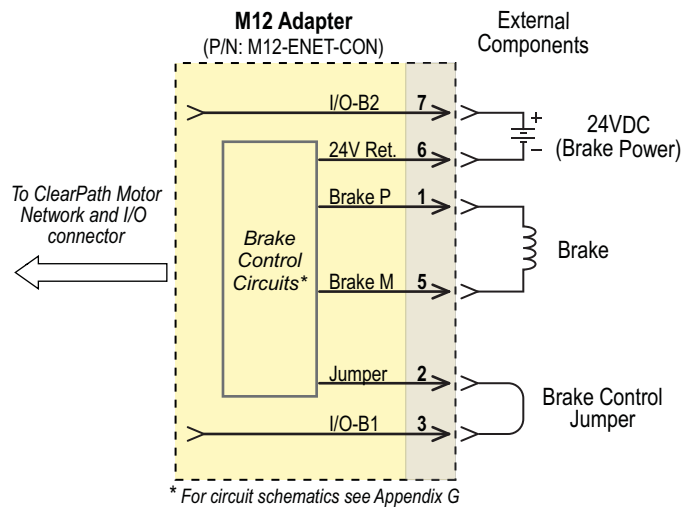

Brake control wiring diagram. (Applies to I/O-B only.)

POWERING CLEARPATH-EC

INTRODUCTION

ClearPath-EC motors in this family require a **DC Bus Motor Power Supply** such as the Teknic IPC-5 (75VDC) described later in this section and online [here](#). **Note:** Properly specified third-party power supplies may also work with ClearPath-EC motors.

ClearPath-EC also supports the use of an optional **Logic Power Backup Supply** for applications requiring uninterrupted Logic Power to keep the motor's processor, communication, and position sensor circuits alive.

DC BUS MOTOR POWER SUPPLY (24-75VDC)

The DC Bus Motor Power Supply provides power to the ClearPath-EC's motor drive circuits. The Teknic IPC-5 (75VDC) is one example of a ClearPath-compatible DC Bus Motor Power Supply.

LOGIC POWER BACKUP SUPPLY (12-75VDC)

Users can opt to use a Logic Power Backup Supply for applications that require uninterrupted power to the motor's low power systems (processor, communication, position sensor circuits, etc.).

Note: Teknic stocks a Logic Backup Power Supply that is 24VDC@6.5A. For more information visit the Teknic webstore and search on part number **PWR-IO-24VDC**, or click [here](#) for a direct link.

The POWER4-HUB-S power distribution board requires a Logic Power Backup Supply in addition to the main DC Bus Motor Power Supply.

Important: Logic Power alone cannot power the motor windings for motion.

BEFORE POWERING A CLEARPATH

- Check for proper DC power polarity before connecting power to a ClearPath. Reversing DC power polarity will permanently damage the motor. Follow this [link](#) for more information.
- Before connecting a power cable to a ClearPath-EC motor, verify that the supply is turned off and discharged to prevent electrical arcing from damaging the connectors.
- **Note:** When a ClearPath motor is powered up, a startup routine energizes the motor for a few milliseconds. During this startup routine a small amount of motion may occur at the motor shaft (<1° typical).

On tightening M12 connectors. For a reliable seal, tighten the communication and power cables between 0.8 Nm-1.4 Nm. **Tip:** When M12 cable connectors are properly tightened there should be no more than 1-2 threads visible on the motor connectors.

POWER DISTRIBUTION BOARDS

ClearPath motors in this family require a power distribution interconnect system to supply DC Bus Motor Power and Logic Power to the motor's power connector. Teknic offers two power distribution boards depending on your needs: The **POWER4-HUB-S** and the **POWER4-STRIP-S**.

POWER4-HUB-S - Distributes DC Bus Motor Power and Logic Power from a separate Logic Power Backup Supply, to up to four ClearPath motors. The DC Bus Motor Power Supply range is 24-75VDC. The Logic Power Backup Supply range is 12-75VDC nominal (though 12V or 24V are most commonly used, especially if Logic Power is supplied by a battery).

POWER4-STRIP-S - Distributes 24-75VDC to the DC motor drive and the logic power circuits. Up to four ClearPath motors can be connected per board. The POWER4-STRIP-S does not use a separate Logic Power Backup Supply.

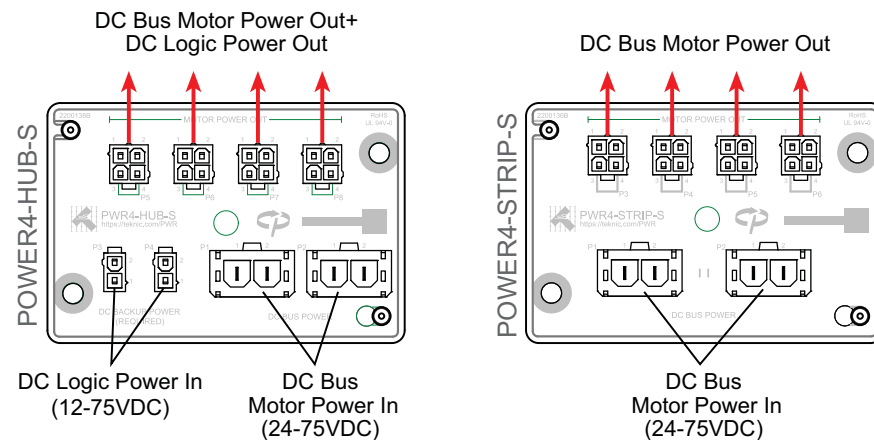

POWER4-HUB-S and POWER4-STRIP-S

POWER4-HUB-S

The **POWER4-HUB-S**:

1. Distributes DC Bus Motor Power to up to four ClearPath motors.
2. Distributes separate Logic Power to the ClearPath motor. Logic Power will keep the motor's processor, encoder position, and associated electronics alive in the event that DC Bus Power drops out for any reason.

Note: Logic Power does not power the motor windings. As such Logic Power alone cannot create torque at the motor shaft.

POWER4-HUB-S SYSTEM DIAGRAM

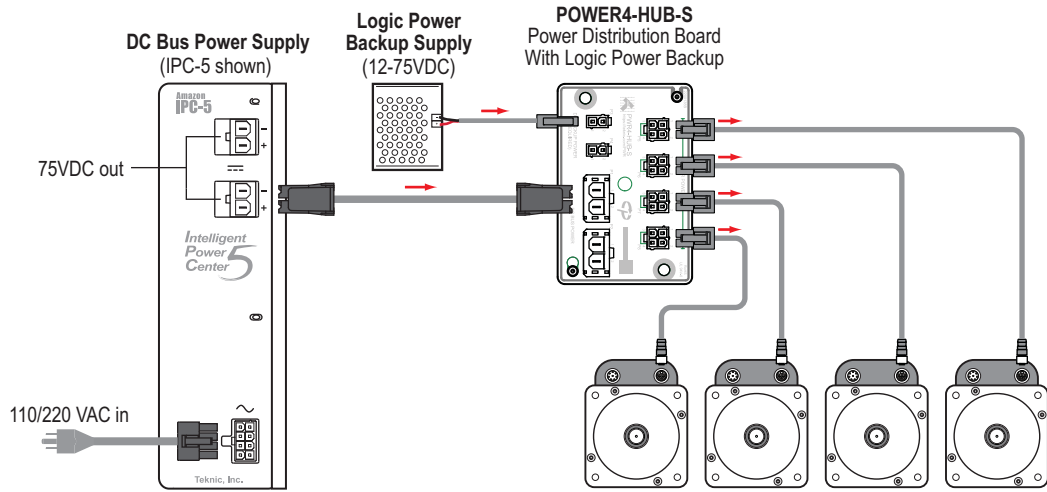

A POWER4-HUB-S in a ClearPath system

POWER4-HUB-S EXPANDED SYSTEM DIAGRAM

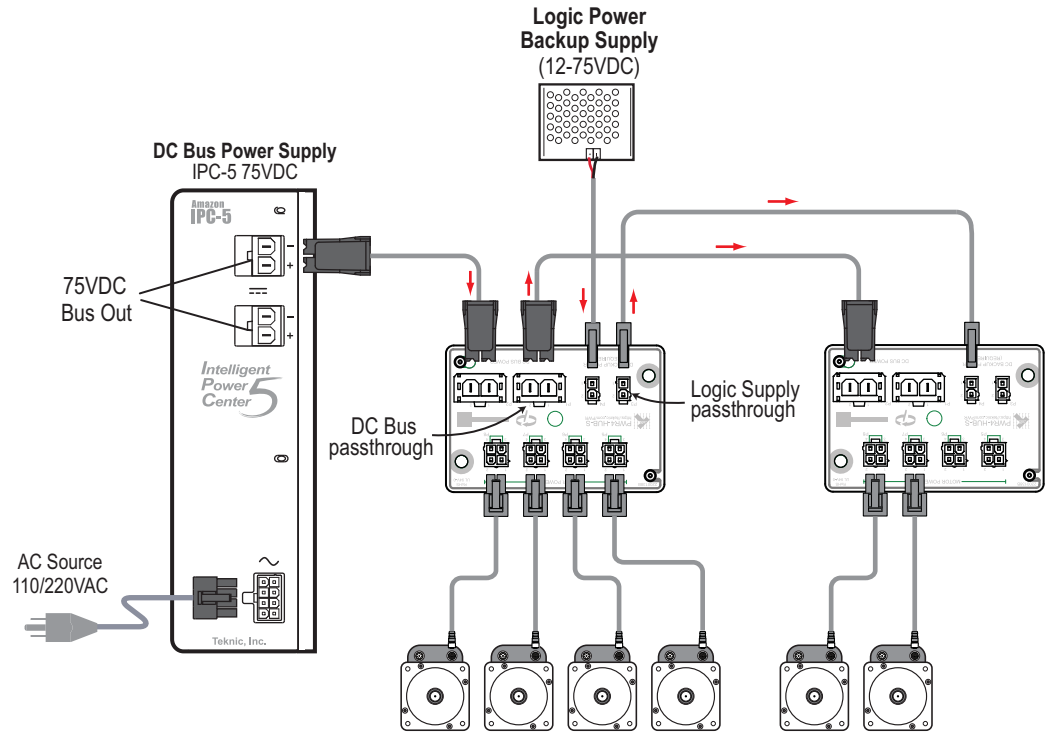

NOTE: The actual number of motors that can be powered by a single DC bus power supply is application and power supply dependent.

Two POWER4-HUB-S boards powering several ClearPath motors

POWER4-HUB-S: THINGS TO KNOW

- **IMPORTANT:** Never connect two IPC-3 / IPC-5 power supplies to a single POWER4-HUB-S. These power supplies are not designed to operate in parallel or series configurations.
- **Logic Power will not spin a motor.** However, Logic Power *will* keep the motor's processor, communication and internal sensor circuits powered.
- **Do not "hot swap" DC power connectors.** Turn off the DC Bus Motor Power Supply before connecting a motor to the POWER4-HUB-S. *Connecting and disconnecting the motor from a live power supply will cause electrical arcing that will damage the connectors over time.*
- **Do not connect more than two POWER4-HUBS to a power supply.** Continuous and peak current usage must not exceed the power supply's specifications.
- **Logic Power requirement per motor:**
 - 2W (9-24VDC)
 - 3W (>24VDC)

IMPORTANT: The Power4-HUB-S board is not considered a shock hazard when the Logic Power Backup Supply is 42VDC or lower (12VDC or 24VDC is the most commonly used voltages for logic backup power). Traces on the exposed (connector side) of the PCBA carrying Logic Power can inadvertently come in contact with a user. **Therefore, if Logic Power is above 42VDC the Power4-HUB-S board must be installed behind a protective cover.**

POWER4-STRIP-S

The **POWER4-STRIP-S** Distributes DC Bus Motor Power to up to four ClearPath motors. This board serves as a basic plug strip for your ClearPath motors.

Note: The POWER4-STRIP-S board does not take a separate Logic Power Backup Supply.

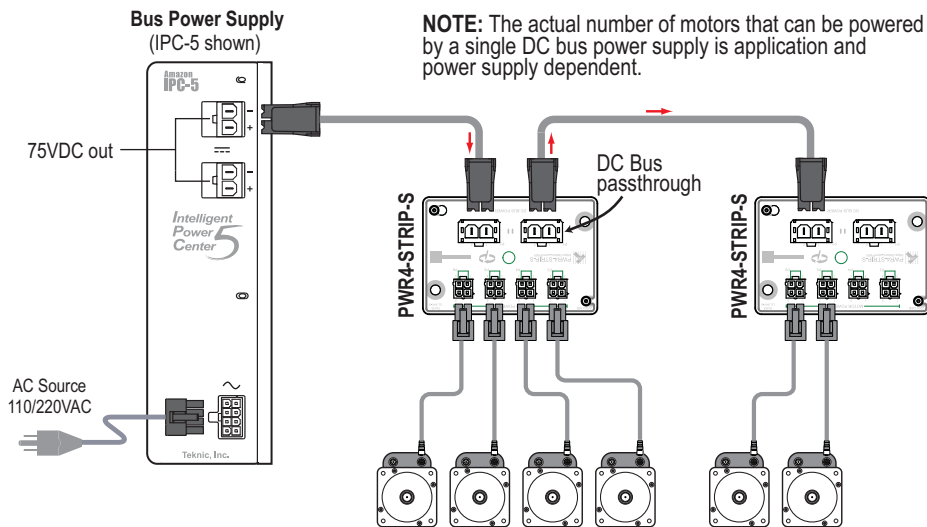
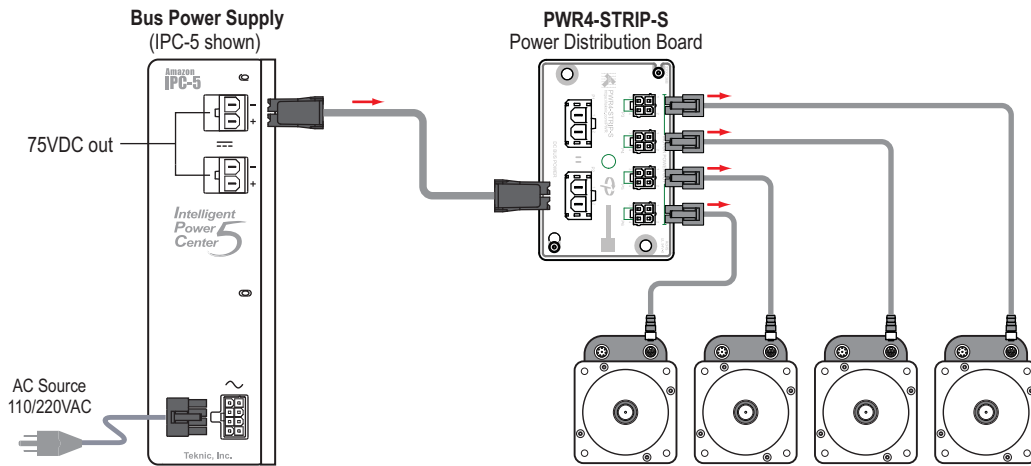

POWER4-STRIP-S boards powering ClearPath motors

POWER4-STRIP-S: THINGS TO KNOW

- **IMPORTANT:** Never connect two IPC-3 or IPC-5 power supplies to a single POWER4-HUB-S. The IPC series power supplies are not designed to operate in parallel or series configurations.
- **Do not "hot swap" DC power connectors.** Turn off DC Bus Motor Power Supply before connecting a motor to the POWER4-STRIP-S. Connecting and disconnecting the motor from a live

power supply will cause electrical arcing that will damage the connectors over time.

- **Do not connect more than two POWER4-STRIP-S boards to a power supply.** Continuous and peak current usage must not exceed the power supply's specifications.

OTHER POWER SUPPLY TOPICS

THE "IDEAL" DC BUS POWER SUPPLY...

...can deliver high peak current (for short periods) and effectively manage regenerated energy (reverse voltage that returns to the power supply and can overload it). Teknic's IPC-3 and IPC-5 are designed with these requirements in mind.

"Bulk" linear power supplies—basically a transformer, rectifier, and large capacitor—can also work well with servo systems

Small switching-mode power supplies are generally not the best choice.

Important: Always test your ClearPath application with the intended power supply under worst case conditions. This may include low AC line, high AC line, heaviest load, highest acceleration/velocity, most aggressive duty-cycle, highest ambient temperature, etc. This will help ensure sufficient power capacity and adequate operating margin.

TEKNIC IPC-3 AND IPC-5

Teknic manufactures the IPC-3 and IPC-5, 75VDC power supplies designed specifically for powering motor drives. These supplies effectively manage peak current demand, regenerated energy, and include many built-in protective features.



Teknic IPC-3



Teknic IPC-5

Teknic 75VDC IPC family power supplies

TEKNIC IPC-3

The IPC-3 open-frame power supply can typically power one to four ClearPath motors. The actual number of motors depends on the application.

TEKNIC IPC-5

The IPC-5 fully enclosed power supply can typically power two to six ClearPath motors. The actual number of motors depends on the torque, speed, and duty cycle required.

UNDERPOWERED DC BUS MOTOR POWER SUPPLIES

ClearPath motors can and do work with power supplies as low as 24 volts DC, provided that the power supply has sufficient voltage, current, and capacitance to meet your application's motor torque and speed requirements.

IMPORTANT: An underpowered supply can result in ClearPath performance limitations and problems including the following:

- **ClearPath is unable to complete the auto-tuning process.** The ClearPath auto-tuning feature uses aggressive moves to test the limits of each mechanical system. A weak power supply (i.e. one that can't handle the peak current demands required by ClearPath) may "droop" the supply below ClearPath's minimum operating voltage, about 21.5VDC. This can cause loss of communication and shutdowns.
- **ClearPath completes the auto-tuning process but experiences warnings or shutdowns during programmed motion.** If Auto-Tune runs to completion, but you experience torque saturation, voltage saturation, or both during regular machine operation, you may be exceeding the supply's voltage and/or current capability.

Possible remedies for underpowered DC Bus Motor Supply

- **Lower the commanded acceleration and/or velocity.** Sometimes lowering commanded acceleration and/or velocity can reduce the burden on a weaker power supply enough to eliminate shutdowns caused by "power starvation".
- **Upgrade to a more powerful supply.** Look for a supply with higher voltage, higher peak and continuous current ratings, and a large capacitor bank.

SWITCHING POWER SUPPLIES

Switching power supplies will work with ClearPath motors but **switchers are often not well-suited to high power servo applications** because they generally have the same peak and continuous current ratings. This can lead the user to purchase a large but ultimately under-worked power supply just to meet peak current requirements.

In addition, most switching supplies are not designed to manage the regenerated energy (back-EMF) that a heavily loaded decelerating motor returns to the power supply, especially when gravitationally loaded. Without special provisions, regenerated energy can cause a switching supply to reset, power cycle, shut down, or even fail.

POWER SUPPLY COMPLIANCE NOTES

- Any 3rd party (non-Teknic) power supply used with the POWER4-HUB-S or PWR-STRIP-S, should be current limited or fused to 25A or less using a 25A, >100VDC fuse.
- If UL compliance is a consideration, select a UL Listed DC fuse.

POWER SUPPLY SWITCHING AND FUSING

POWER SUPPLY CONTROL SWITCH

The power supply for a ClearPath should not be switched on and off from the DC output side. Switching the DC output side, especially with inexpensive relays, will ultimately result in poor performance (drop outs) due to pitting, corrosion and contact welding. If a power switch is required, install it such that the supply is disconnected from the AC input side (see figure below).

POWER SUPPLY FUSING

If you require an external fuse on your power supply's DC output (to meet compliance standards for example) it should be installed in line with the positive leg of the DC output wiring. Use a maximum 10A time delay fuse.

FAQ: "WHAT SIZE DC BUS MOTOR POWER SUPPLY SHOULD I USE?"

Our engineers are asked this question all the time, and the short answer is: "it depends".

The exact power requirements for a given machine depend on several interrelated factors, including the number and type of motors and drives connected to the supply, the torque and speed requirement for each motor, environmental factors, and more.

Calculating the torque requirement for just a single axis can be challenging. This involves analysis of gearing, loading (both static and dynamic), reflected inertia, gravitational effects, friction, target accelerations, velocities, and machine throughput requirements.

Analyzing the machine as a system, i.e. as a group of axes working together under all possible operational conditions adds even more complexity. At the systems level, factors such as axis duty cycle, effects of synchronous motion, and regenerated energy come into play.

in the end, selecting a power supply often begins with an educated guess followed by real-world testing. If you need to power several motors running at high speed and high torque, consider using a Teknic IPC-5, 75VDC power supply. Start with one supply but keep in mind that you can add another supply later if your application requires more power. If your machine is a single axis moving a light load at relatively low speed, a less powerful supply will probably suffice. Just be aware that testing is the best way to be sure you have a good power supply solution.

SOFTWARE (CLEARVIEW 3.0)

ClearView 3.0 software provides a suite of powerful configuration, analysis, and diagnostic tools to speed machine and software development. These tools—the Soft Scope in particular—make it easy to capture and share key motion performance data.

MINIMUM SYSTEM REQUIREMENTS

Operating System:	Windows 10, 11
Processor:	1.5 GHz or faster
Memory:	1 GB RAM
HD Free Space:	1 GB
Monitor:	1280 x 1024 pixels or higher
Other:	Sound card with speakers (optional)

INSTALLING CLEARVIEW 3.0 SOFTWARE

- Download the ClearView 3.0 installer from <https://www.teknic.com/downloads/>.
- Launch the ClearView 3.0 installer.

CLEARVIEW 3.0 SOFTWARE TOUR

The ClearView 3.0 UI consists of four main parts: the *Menu*, *Manual Controls*, *Dashboard*, and *Soft Scope*.

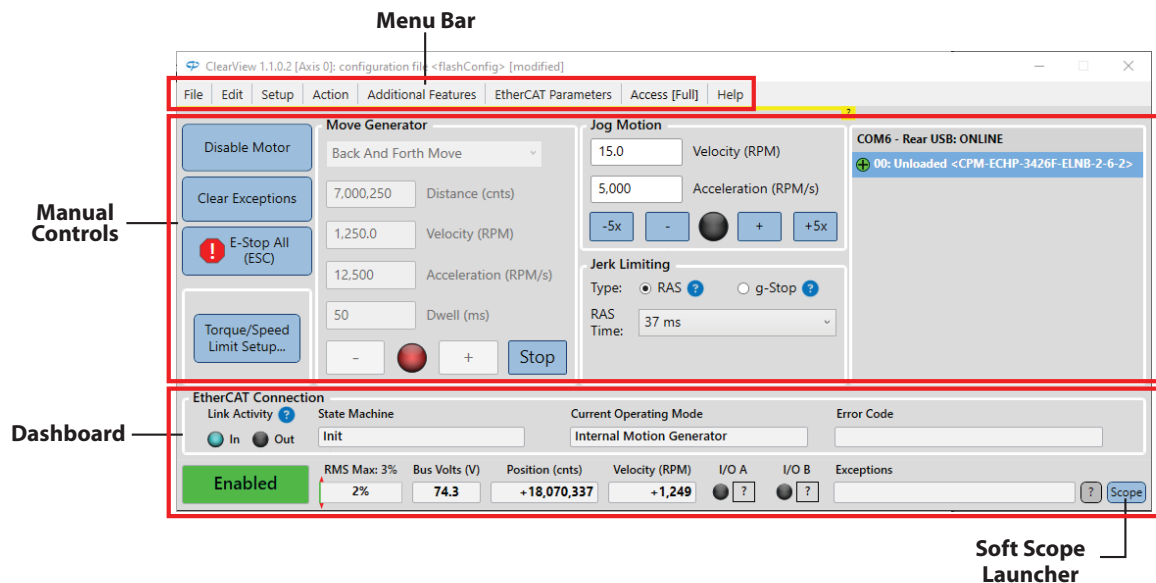

ClearView 3.0 UI Overview

MANUAL MOTOR CONTROLS

The Manual Motor Controls are a set of tools designed to help you test and exercise your ClearPath-EC motors without a Master and *without writing code*. Manual Controls allow you to:

- Enable, disable, and E-stop motors
- Manually jog motors
- Make predefined moves (single, repeating back-and-forth, or repeating in the same direction)
- Clear shutdowns/exceptions
- Modify maximum torque and speed

The screenshot shows the Manual Motor Controls interface with the following callouts:

- Enable/Disable**: Click to enable or disable the motor.
- Move Parameters**: Set desired velocity, acceleration, etc. for Move Generator.
- Jog Buttons**: Click and hold to jog in (+) or (-) direction.
- Motor Selector**: Select any motor listed here to make it the current "Active Motor".
- Clear Exceptions**: A button to clear exceptions.
- Move Type Selector**: Choose from *Single Move, Back and Forth, Repeating Move, and Constant Velocity*.
- Jog Parameters**: Set jog velocity and acceleration here.
- Fast Jog Buttons**: Click and hold to jog at 5x the current velocity parameter.
- Disable Motor**: A button to disable the motor.
- Clear Exceptions**: A button to clear exceptions.
- E-Stop All (ESC)**: A button with a red exclamation mark to stop all motors.
- Torque/Speed Limit Setup...**: A button to access torque and speed limit settings.
- Move Generator**: Contains a dropdown menu (set to "Back And Forth Move"), input fields for Distance (cnts) (7,000,250), Velocity (RPM) (1,250.0), Acceleration (RPM/s) (12,500), and Dwell (ms) (500). It also has - and + buttons and a Stop button.
- Jog Motion**: Contains input fields for Velocity (RPM) (15.0) and Acceleration (RPM/s) (5,000), and buttons for -5x, -, +, and +5x.
- Jerk Limiting**: Contains radio buttons for Type: RAS (selected) and g-Stop, and a dropdown for RAS Time: 37 ms.
- Jerk Limit Controls (RAS and g-Stop)**: A label for the Jerk Limiting section.
- Start Move**: Click (+) to start move cycle in CCW direction. Click (-) to start move in CW direction.
- Stop Move**: Single click stops motion after move completes. Double click stops motion immediately.
- E-stop Button**: Click to immediately E-stop all motors on the current port.
- Torque/Speed Limit Setup**: A button to access torque and speed limit settings.
- COM6 - Rear USB: ONLINE**: A status indicator.
- 00: Unloaded <CPM-ECHP**: A status indicator for the active motor.

Manual Controls section of ClearView 3.0

DASHBOARD

The Dashboard contains a number of visual elements (virtual LEDs, meters, numerical readouts) to give the user real-time access to key motor information including motor status, encoder position, motor velocity, bus voltage, I/O states, exception messages, etc.

EtherCAT State Machine (ESM)
Different functions are accessible depending on the current state.

Link Activity Display
Black: No link, no activity
Blue: Link detected, no activity
Yellow: Link detected, has activity

DC Bus Power Supply Voltage

Operating Mode
Displays the current motor operating mode.

Error Code
Displays any active error codes (e.g. 0x603F)

Exception Information
Click here to open a dialog box containing additional information on any active exception or shutdown.

Motor/Drive Status
(Tip: double click to clear exceptions).

RMS Meter
Displays real-time (and maximum recorded) RMS motor current. ClearPath shuts down if RMS reaches 100% to prevent burnout.

Position Counter
Displays position of motor shaft in encoder counts.

Velocity Meter
Displays motor shaft velocity in kcounts/sec or RPM.

I/O-A, I/O-B Status LEDs
LED on = Input asserted
LED off = Input de-asserted

Exception Messages
Displays a brief message related to any active ClearPath exception.

Soft Scope Launcher
Click to open Soft Scope.

Motor Status Messages

Enabled	Motor is enabled. Caution: Motor coils are energized.
Disabled	Motor is disabled. Motor coils are not energized.
E-Stop	An E-stop was issued. Motor coils are not energized.
Shutdown	ClearPath is in a shutdown state. Motor coils are not energized.

Dashboard section of ClearView 3.0

SOFT SCOPE

OVERVIEW

The Soft Scope takes real-time streaming data from your ClearPath-EC motor and plots it on a scope display similar to that of a hardware oscilloscope. The Soft Scope can display the motor's *actual torque output*, *following error*, *commanded velocity*, *acceleration*, and more. This tool helps users and support professionals more easily analyze and troubleshooting motor hardware, motion quality, and mechanical system performance.

The Soft Scope consists of three main sections: the **Scope Display (1)**, **Strip Charts (2)**, and **Scope Controls (3)**.

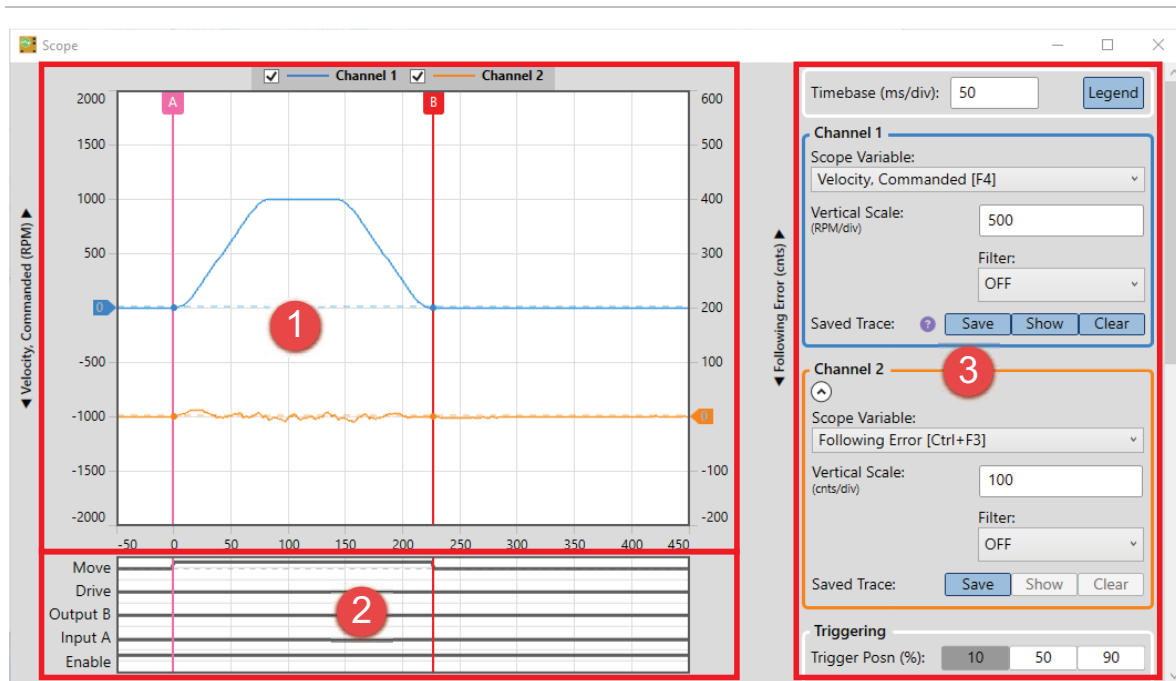

ClearView 3.0 Soft Scope

SOFT SCOPE FEATURES

- Many scope variables that can be plotted in real time
- 5 trigger modes
- Adjustable time-base, range, and trigger position
- Display and compare stored traces and live traces
- Many trigger presets (e.g.: trigger at end of settled move)
- Vertical and horizontal cursors for precise timing and amplitude measurements
- Strip Charts for a consolidated view of motor status, I/O states, and move timing

SCOPE DISPLAY AND CONTROLS

The ClearView Scope display is modeled after a typical hardware oscilloscope. It has 10 major vertical divisions (the time axis), and 8 major horizontal divisions (the amplitude axis).

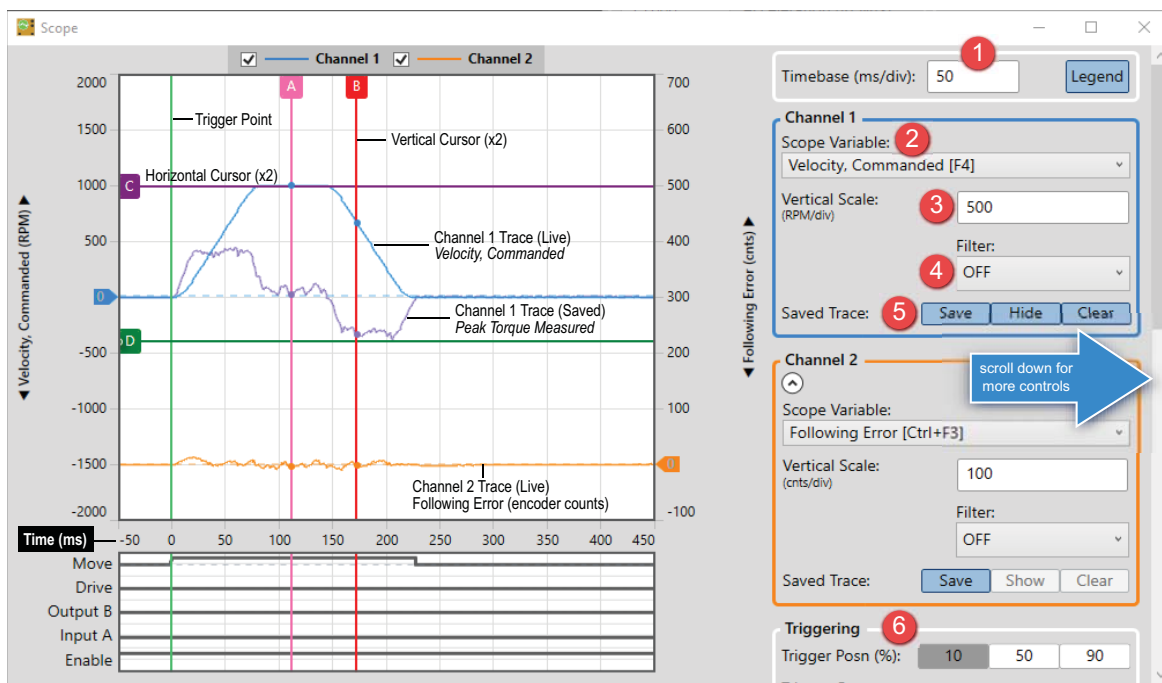

ClearView Soft Scope

1 The Timebase field lets you adjust the scale of the time axis in units of mS/division. This allows you to control how a waveform fits horizontally on the Scope Display.

2 The Scope Variable drop down menu lets you select the ClearPath-EC motion control variables to display. See figure below.

- Velocity, Commanded [F4]
- Following Error [F3]
- Velocity, Commanded [F4]
- Torque Measured, Peak [F5]
- Torque Utilization [F6]
- Velocity Error, Gated
- Bus Voltage
- Max Phase Voltage
- Torque, Commanded
- Position, Measured
- Acceleration, Commanded
- Jerk, Commanded
- Torque Error, Peak
- Velocity, Measured

3 The Vertical Scale field lets you adjust the scale of the amplitude axis (Y-axis). This allows you to control how a waveform fits vertically on the Scope Display.

4 The Scope Filter “cleans up” or smoothes the appearance of the displayed trace by removing higher frequency data content. This has an averaging effect on the displayed waveform that can help mitigate the effect of noise (or just remove visual clutter) on the displayed signal.

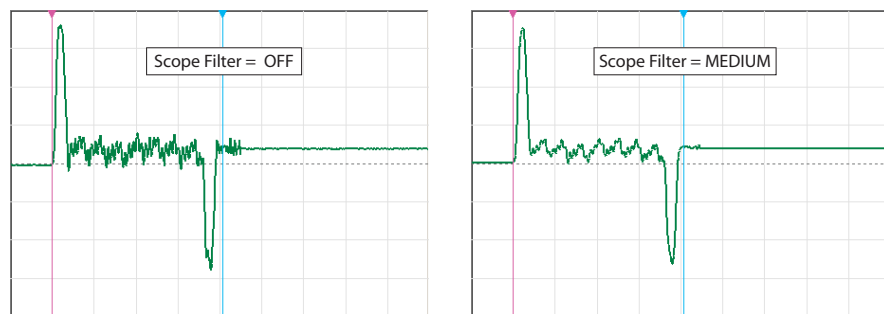

Effect of Scope Filter on trace display

Note: The Scope Filter has no effect on motor performance. *It changes only how scope data is displayed.*

Note: Higher filter setting may filter out meaningful data points from the display, rapid peaks in particular.

5 Save Trace controls lets you save and display a trace on the scope display. Hide or clear a saved trace with the corresponding button.

6 Trigger Controls Let you set and change **Trigger Position** on the scope display. This can help users easily capture events on the scope that occur before, during, or after the trigger point.

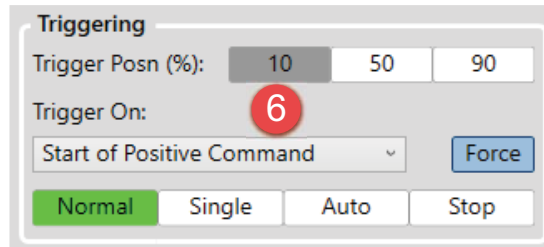

Use **Trigger On** drop down menu to tell the scope on what event it should start capturing and displaying scope data. (For use in Normal and Single modes only.)

Trigger modes determine how the scope displays data as follows:

- **Normal** - Causes scope data collection to begin when a valid trigger event is detected.
- **Single** - Works similarly to *Normal* mode, except it captures only a single data set when a valid trigger event is detected. After the single sweep capture, data collection automatically stops.
- **Auto** - Data is continuously collected, refreshed, and displayed regardless of the trigger source settings.
- **Force** - Click to force the scope to immediately trigger one time, regardless of trigger source setting.
- **Stop** - Immediately stops data collection.

6 (continued) **Trigger Source "Trigger On"** menu lets you choose what conditions must be met before scope data collection is triggered. (For use with Normal and Single modes only.)

If Trigger Source is set to:	Soft Scope will:
Start of Positive Command	Trigger at the start of any positive move; useful for tuning.
Start of Negative Command	Trigger at the start of any negative move; useful for tuning.
Start of Any Command	Trigger at the start of any move (positive or negative); useful for assessing bi-directional tuning performance.
End of Positive Command	Trigger at the end of any positive move; useful for assessing settling performance.
End of Negative Command	Trigger at the end of any negative move; useful for assessing settling performance.
End of Any Command	Trigger at the end of any move (positive or negative); useful for assessing bi-directional settling.
End of Positive Settled Move	Trigger at the end of any positive move after Move Done criteria are met; useful for assessing settling performance.
End of Negative Settled Move	Trigger at the end of any negative move after Move Done criteria are met; useful for assessing settling performance.
End of Any Settled Move	Trigger at the end of any move (positive or negative) after Move Done criteria are met; useful for assessing settling performance.
Voltage/Torque/Speed Limit	Trigger on first occurrence of saturation (voltage or torque) or upon speed limiting; useful for determining which moves (or segments of moves) exceed these thresholds.
Drive Shutdown or Exception	Trigger on the assertion of an exception or safety shutdown; useful for determining the operational status at the time of a fault.
Input A/B Turns On	Trigger when designated input turns on.
Input A/B Turns Off	Trigger when designated input turns off.

7 Zooming allow you to zoom and pan on the scope display. Click the  symbol for specifics on how to use the zoom functions.

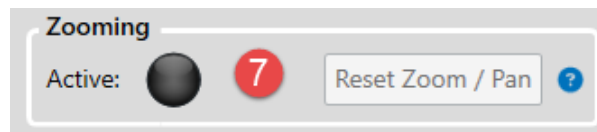

8 Cursor Readings Displays time and amplitude measurements of the vertical and horizontal cursors on your scope display. Click the **Measure Move** button to automatically place the vertical cursors at the beginning and end of a move to quickly determine total move time. Click **Reset Cursors** if cursors are not visible.

	Time ms	Ch1 RPM	Ch2 cnts
A	41.0	470	5
B	154.0	930	-7
Δ	113.0	460	-12

9 I/O Display Setup Sets I/O-A and I/O-B to display as either an input or an output on the strip chart.

CLEARVIEW 3.0 MENUS

FILE MENU

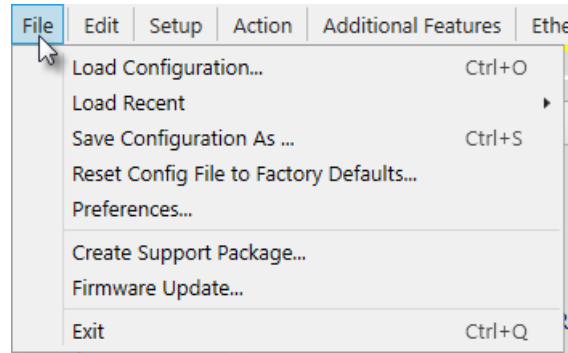

File Menu

Load Configuration. Used to load motor configuration files into your ClearPath-EC motor. The file extension is .mtr.

Load Recent. Lets you select a motor configuration file from a list of the most recently saved .mtr files.

Save Configuration. Used to save your ClearPath-EC motor configuration file as a .mtr file.

Reset Config File to Factory Defaults. Restores ClearPath-EC to its factory default configuration (i.e., the way it was configured when you received it). All existing settings will be overwritten. Save your current configuration as a .mtr file (described above) if you think you'll need to use it some other time.

Preferences and Port Select. Used to select COM ports and turn Event Sounds on or off.

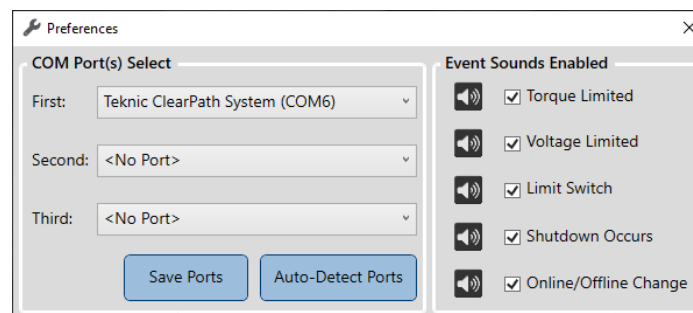

Create Support Package. Creates a .zip file containing comprehensive system diagnostic data. Typically for use by a Teknic application engineer.

Firmware Update. Use this command to update your motor's firmware.

EDIT MENU

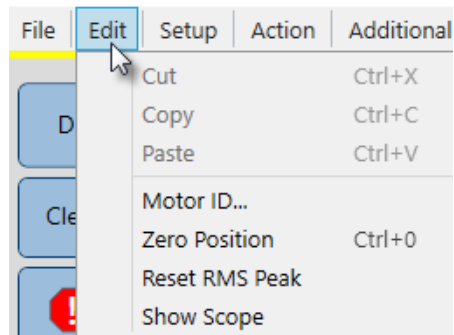

Edit Menu

Cut, Copy, Paste. (Standard Windows commands)

Motor ID. Opens a window where you can enter a name and brief description for your ClearPath-EC motor.

Motor ID Setup

Motor Name
This is a user-defined name for the motor (up to 25 characters) that is shown in the Motor List.
For example, "Titan x-axis".

Axis 0 _CPM-ECHP-3441F-EL

Mechanical System Description
This description identifies what was connected to the motor when it was auto-tuned. This allows you to recognize if the mechanics have been changed since the auto-tuning procedure.
For example, "Ballscrew: 1m long, 15mm dia., 5mm pitch. Load mass 10kg. Bearing wiper removed. Medium cable track."
Available characters = 63

5mm pitch ballscrew carrying 5kg payload. Max speed 2350 RPM.

Verify Tuning Upon Connection
Upon USB connection, ClearView can remind you to start the auto-tuning process if the mechanics have changed since the motor was last auto-tuned. To prevent this reminder from appearing for this serial number motor, check the box below.

I will remember to re-tune if the mechanical system changes. Do not ask again for this motor.

OK Cancel

Zero Position. Sets the Position Counter to zero. Note: In certain modes, double-clicking the Position Counter directly in the UI will also zero the position counter.

Reset RMS Peak This applies to the RMS Meter in the Dashboard section of MSP. Click this menu item to reset *RMS Max* (this is the maximum RMS value recorded since last motor reset).

Show Scope. Launches the Soft Scope in its own window.

SETUP MENU

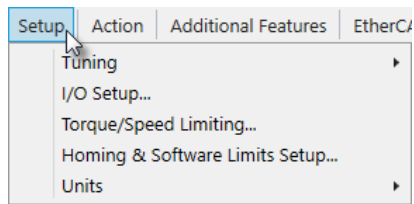

Setup Window

Tuning

- **Auto-Tune.** Opens the Auto-tune wizard which walks the user through the Auto-tune process in a safe, step-by-step manner.
- **Fine Tuning.** This slider control lets you stiffen or soften tuning performance.

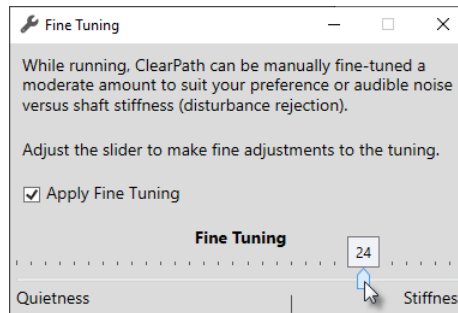

I/O Setup. Used to assign functionality to Inputs A and B. These I/O points can be configured as inputs for limit switches, home sensors, and touch sensors, and to act as a brake control output (*Input B only*).

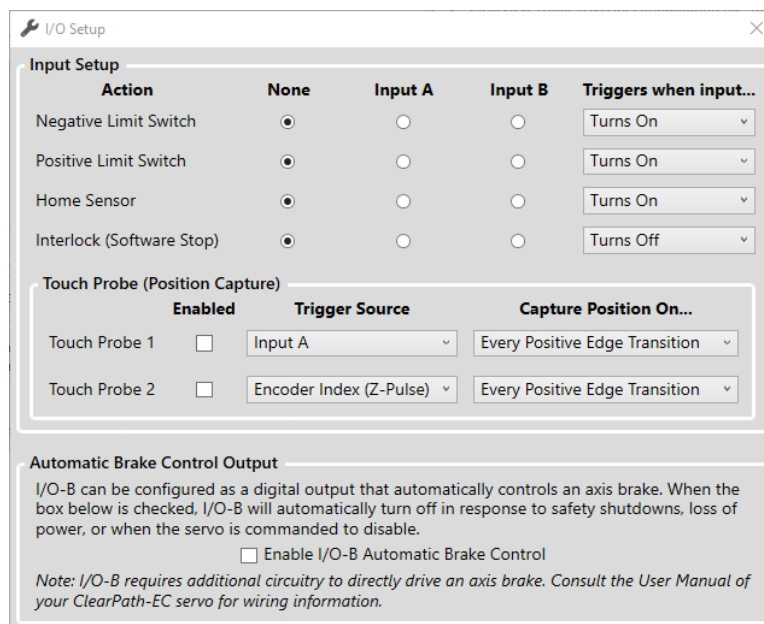

Torque/Speed Limiting. Used to set maximum motor torque and speed settings.

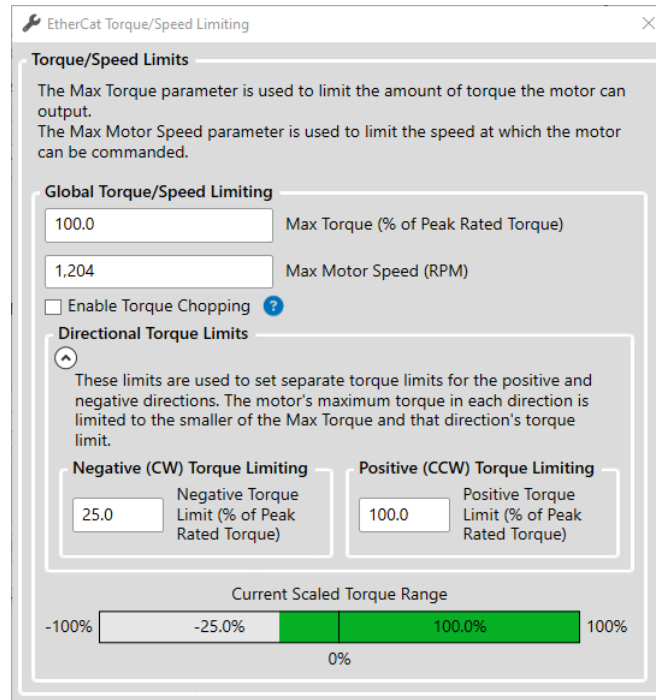

Homing and Position Limits Setup. See dialog text for details.

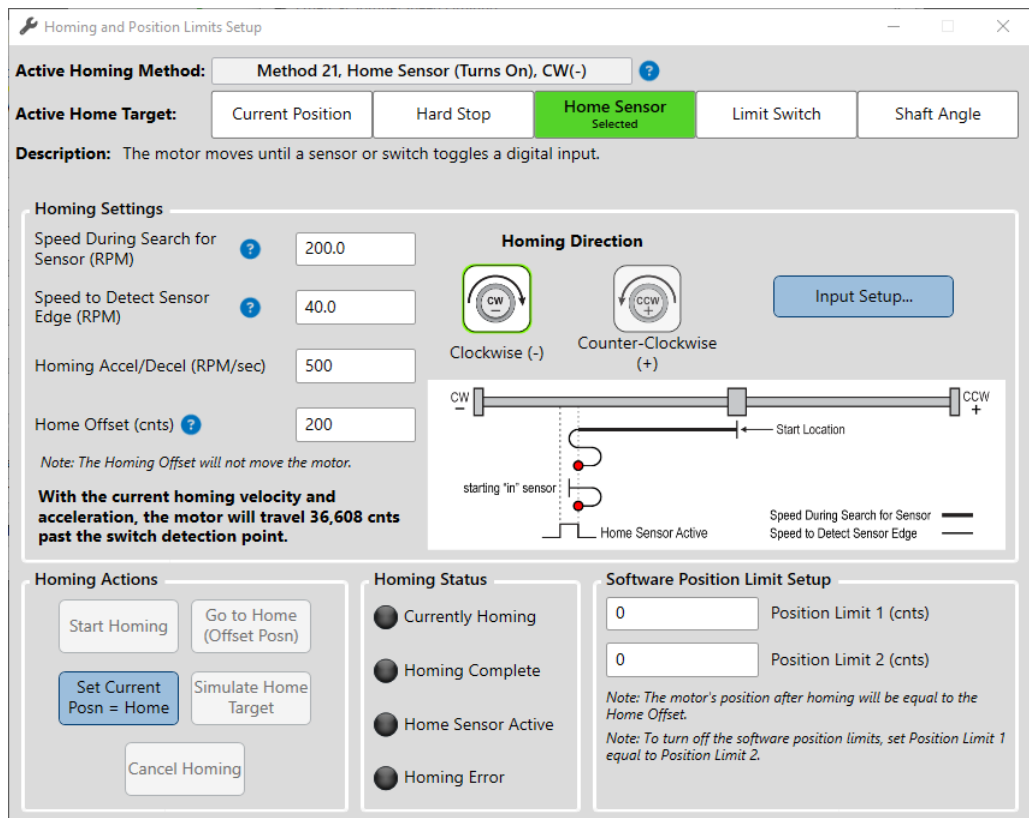

Units. Lets the user choose which units to display for velocity and acceleration values (motor encoder counts or RPM). Distances are always displayed in motor encoder counts.

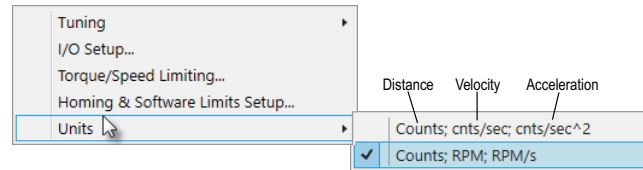

ACTION MENU

Action	Additional Features	EtherCAT Paramet
EStop All (Esc)		F12
Clear E-Stop		Shift+F12
Clear All Exceptions		Ctrl+Shift+F12
Enable All		Ctrl+E
Disable All		Ctrl+D
I/O Manual Control...		
Reset Node		Ctrl+R

Action Menu

E-Stop All. Issues an E-stop (node stop) to all ClearPath-EC motors on the port.

Clear E-Stop. Clears E-stop and returns motor to previous operating state.

Clear All Exceptions. Clears exception state and messages. Note: The exception condition may recur if the underlying issue is not resolved.

Enable All. Enables all motors on the port.

Disable All. Disables all motors on the port.

Reset Node. Resets the currently selected motor.

I/O Manual Control. Lets the user manually control I/O-A and I/O-B.

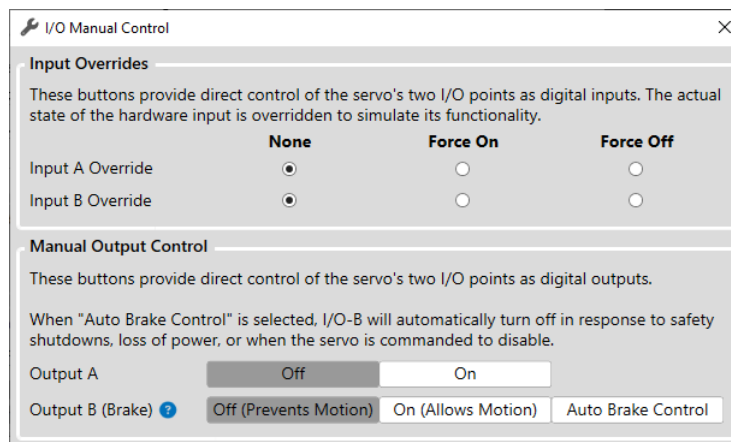

ADDITIONAL FEATURES MENU

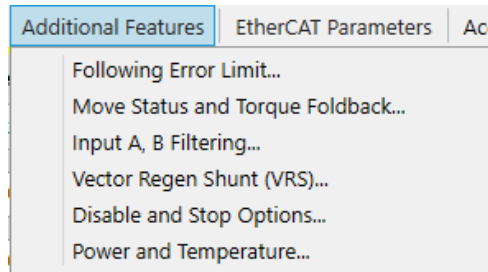

Additional Features Menu

Following Error Limit. Following error is defined as the difference between the encoder's *commanded* position and its *actual* position. The Following Error Limit tells ClearPath how many encoder counts of error to allow before triggering a safety shutdown.

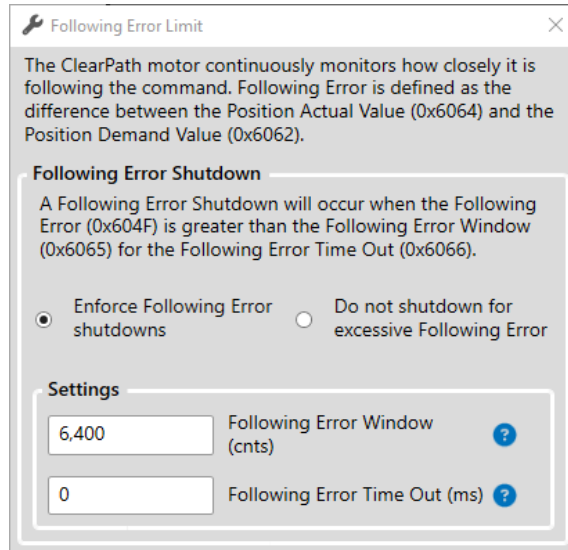

Move Status and Torque Foldback. See dialog text for details.

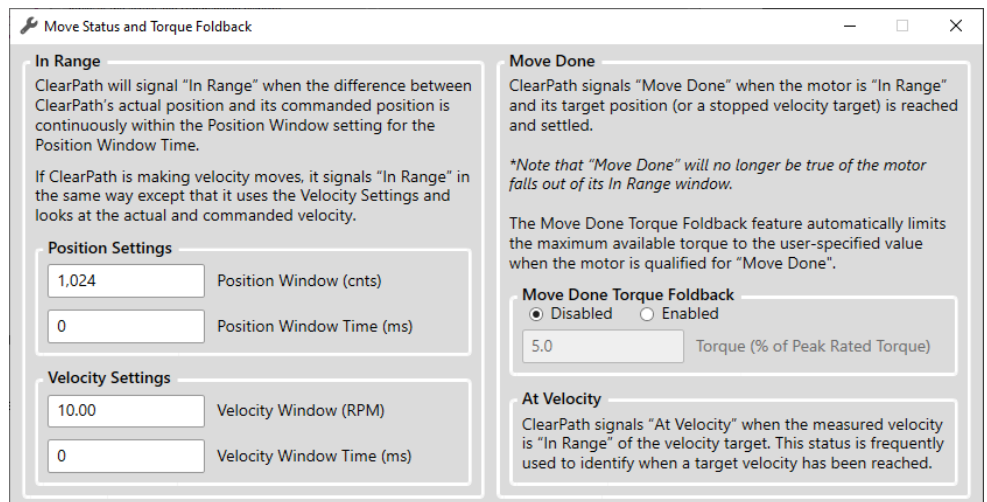

Input A, B Filtering. See dialog text for details.

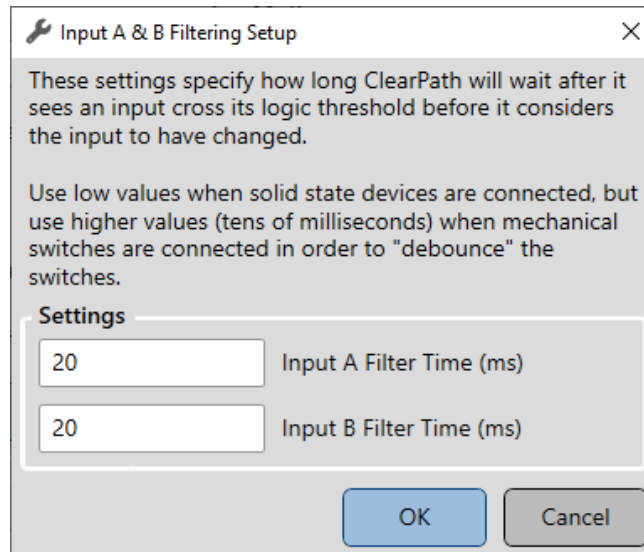

Vector Regen Shunt. See dialog text for details.

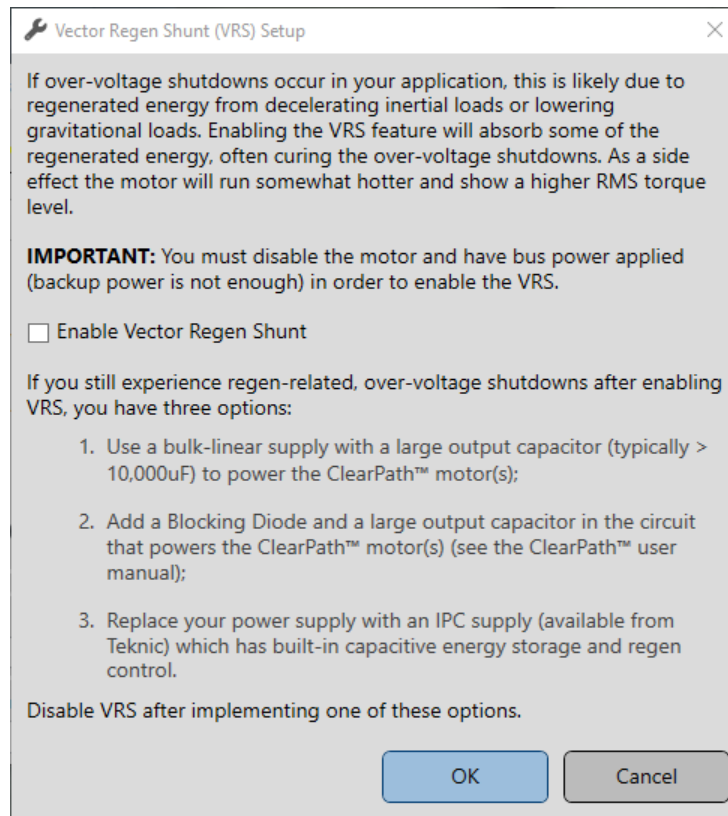

Disable and Stop Options. Opens a multi-tab window that lets the user define how the motor will behave upon Disable, Quick Stop, Halt, and Fault conditions.

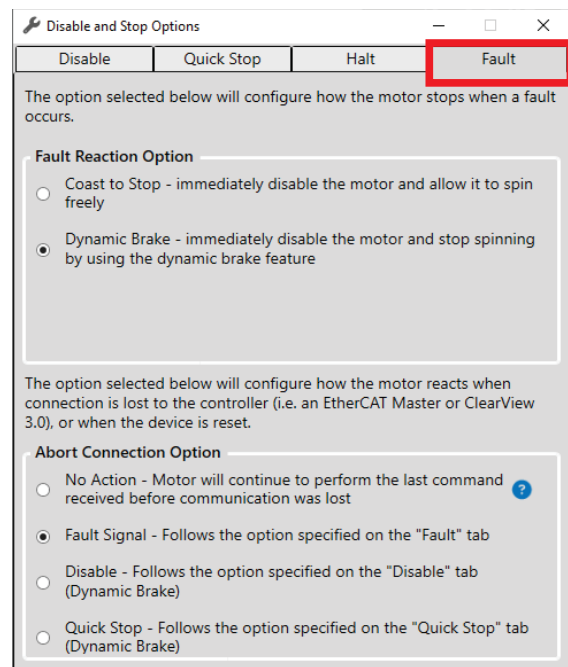
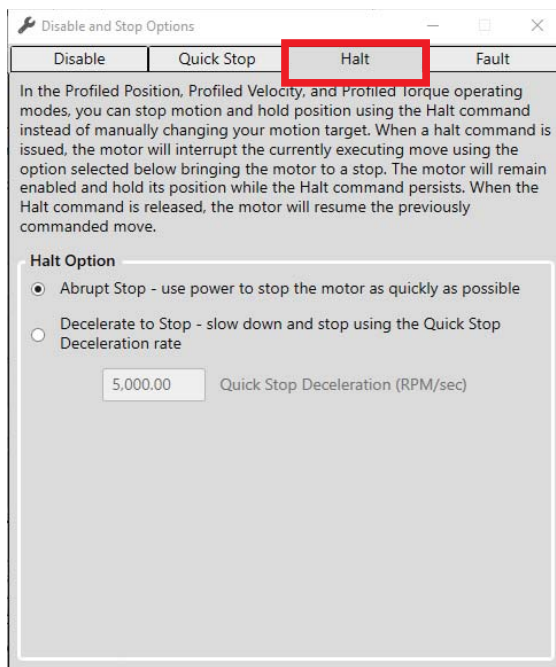
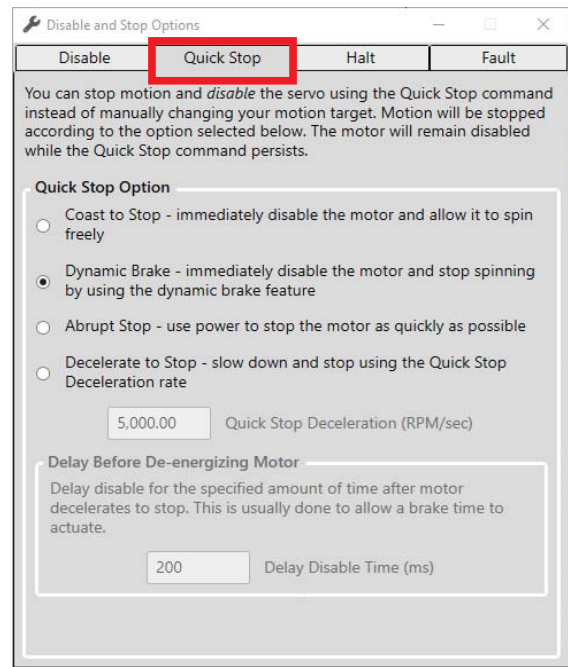
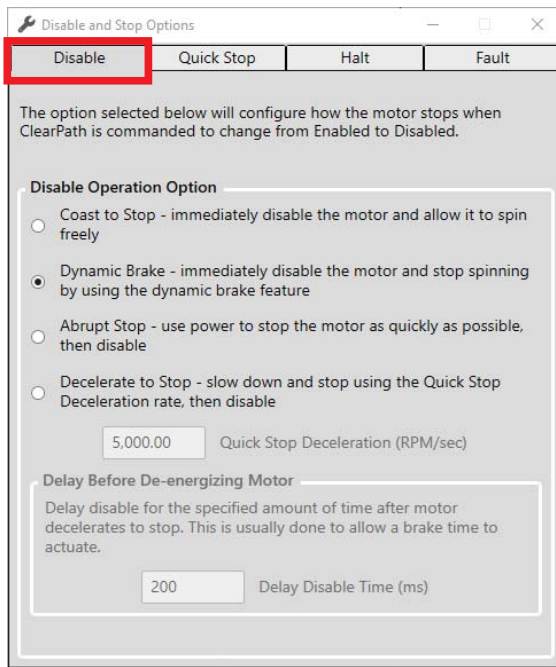

Power and Temperature Settings and Status. Use these settings to:

- Configure ClearPath to shut down or issue a warning when DC bus voltage falls below the Low Voltage Exception Threshold.
- Change Bus Current Trip Point. This parameter is commonly left at the default value.
- View the current temperature of the ClearPath drive board.
- Set the Maximum Drive Temperature (the threshold at which ClearPath will throw an over-temperature shutdown.)

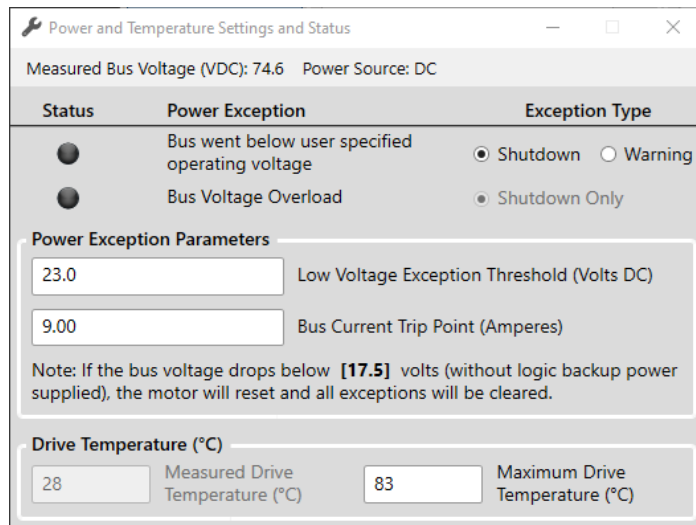

ETHERCAT PARAMETERS MENU

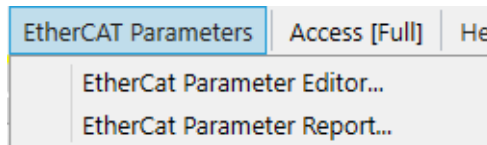

EtherCAT Parameters Menu

EtherCAT Parameter Editor. Lets the user modify EtherCAT parameters manually within ClearView 3.0.

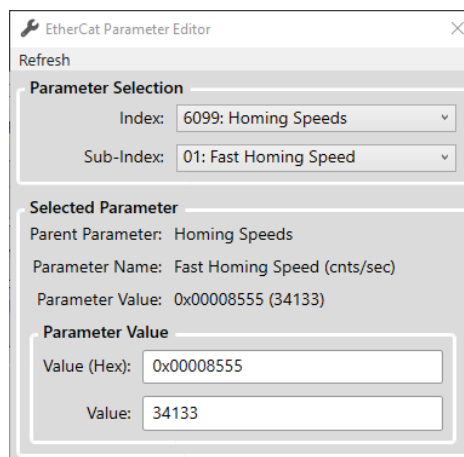

EtherCAT Parameter Report. Opens a report containing a snapshot of the EtherCAT parameters stored in the motor.

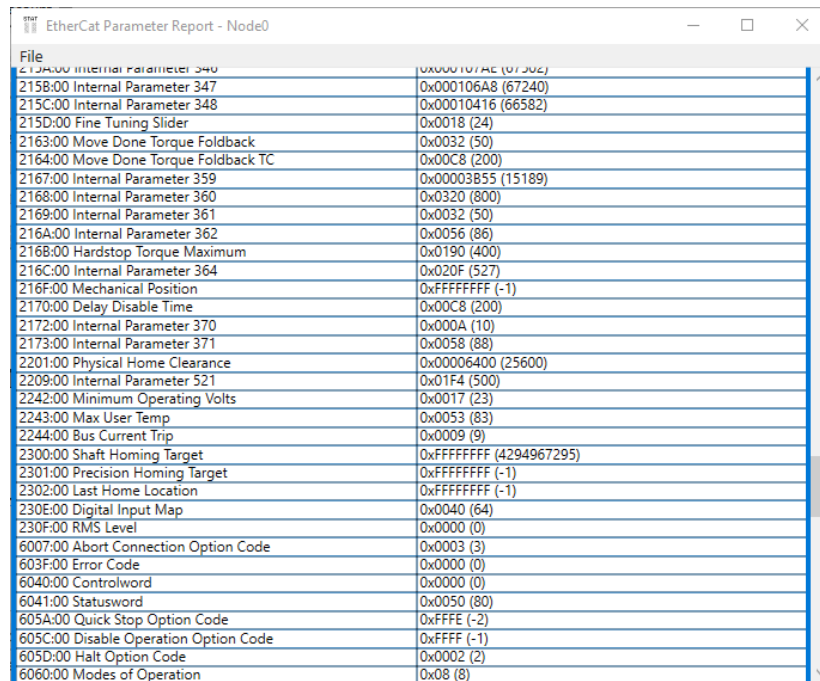

Address	Parameter Name	Value
215A:00	Internal Parameter 340	0x000107AE (07302)
215B:00	Internal Parameter 347	0x000106A8 (67240)
215C:00	Internal Parameter 348	0x00010416 (66582)
215D:00	Fine Tuning Slider	0x0018 (24)
2163:00	Move Done Torque Foldback	0x0032 (50)
2164:00	Move Done Torque Foldback TC	0x00C8 (200)
2167:00	Internal Parameter 359	0x00003855 (15189)
2168:00	Internal Parameter 360	0x0320 (800)
2169:00	Internal Parameter 361	0x0032 (50)
216A:00	Internal Parameter 362	0x0056 (86)
216B:00	Hardstop Torque Maximum	0x0190 (400)
216C:00	Internal Parameter 364	0x020F (527)
216F:00	Mechanical Position	0xFFFFFFFF (-1)
2170:00	Delay Disable Time	0x00C8 (200)
2172:00	Internal Parameter 370	0x000A (10)
2173:00	Internal Parameter 371	0x0058 (88)
2201:00	Physical Home Clearance	0x00006400 (25600)
2209:00	Internal Parameter 521	0x01F4 (500)
2242:00	Minimum Operating Volts	0x0017 (23)
2243:00	Max User Temp	0x0053 (83)
2244:00	Bus Current Trip	0x0009 (9)
2300:00	Shaft Homing Target	0xFFFFFFFF (4294967295)
2301:00	Precision Homing Target	0xFFFFFFFF (-1)
2302:00	Last Home Location	0xFFFFFFFF (-1)
230E:00	Digital Input Map	0x0040 (64)
230F:00	RMS Level	0x0000 (0)
6007:00	Abort Connection Option Code	0x0003 (3)
603F:00	Error Code	0x0000 (0)
6040:00	Controlword	0x0000 (0)
6041:00	Statusword	0x0050 (80)
605A:00	Quick Stop Option Code	0xFFFF (-2)
605C:00	Disable Operation Option Code	0xFFFF (-1)
605D:00	Halt Option Code	0x0002 (2)
6060:00	Modes of Operation	0x08 (8)

ACCESS MENU

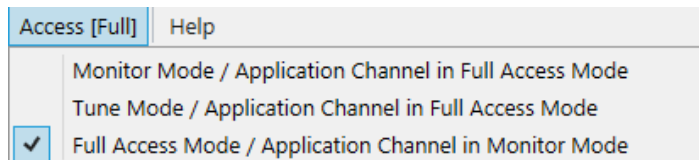

Access Menu

Allows the user to grant partial or full access to the motor settings via a second "Diagnostic PC" connected to the motor's rear Diagnostic Port.

Access is required to perform certain tasks in ClearView 3.0, such as using the Soft Scope, Auto-Tuning, and changing parameters and settings.

See the following section (Using the Diagnostic Port) for full details on how to connect a diagnostic computer to a ClearPath-EC motor.

USING THE DIAGNOSTIC PORT

EtherCAT Port vs. Diagnostic Port

ClearPath-EC motors communicate with the EtherCAT Master over the **EtherCAT Port**.

The Diagnostic Port is used for temporary tasks such as motor configuration and diagnostic work. It requires a separate PC running ClearView 3.0. Communication occurs through the motor's rear USB-IR Port.

A key benefit of the Diagnostic Port is that it allows the user to run their machine software on the "main" channel (aka, the EtherCAT Port) while simultaneously monitoring performance on the Diagnostic Port.

TERMS USED IN THIS SECTION

Master. This is the EtherCAT Master device that controls the machine application.

EtherCAT Port. This is the communication channel between the Master and the ClearPath-EC motors.

Diagnostic Port. This is a secondary data channel that sends data between the ClearPath-EC and a separate PC running ClearView 3.0. The Diagnostic Port is accessed via the **USB-IR Port** on the back of the motor.

CONNECTING TO THE MOTOR DIAGNOSTIC PORT

1. Connect a USB cable (Type A-C) to the USB-IR Converter and magnetically attach to the motor's USB-IR Port. Then plug the other side into your PC.

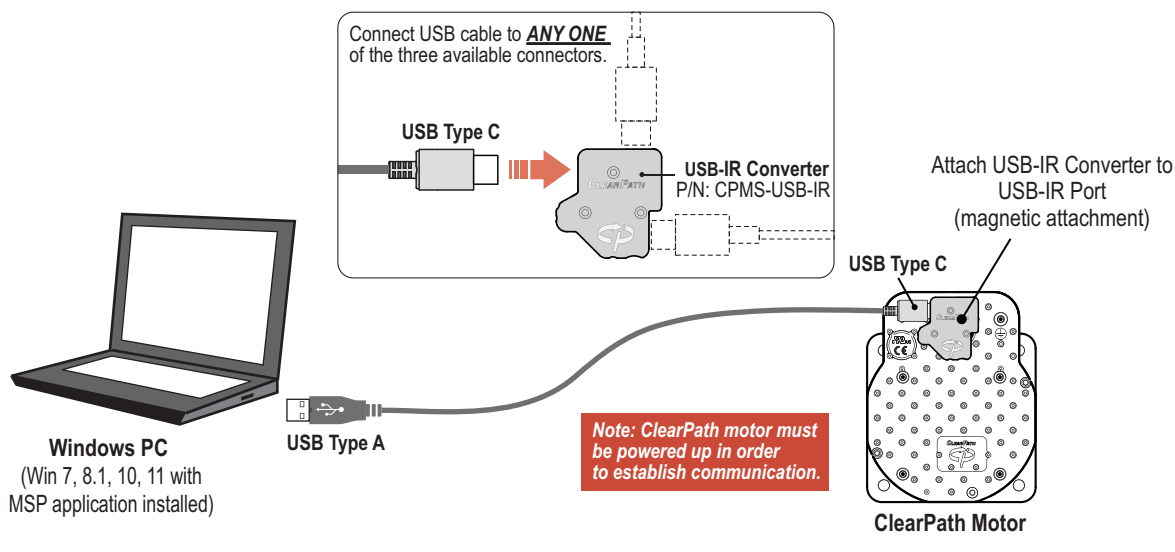

2. ClearView 3.0 should automatically identify your motors as shown below.

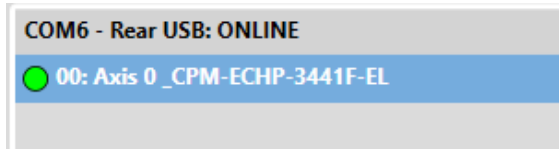

CHANGING DIAGNOSTIC PORT ACCESS MODES

Set the access level from the Access menu in ClearView 3.0. Users primarily use *Monitor Mode* or *Tune Mode*. Note: Access modes are explained below.

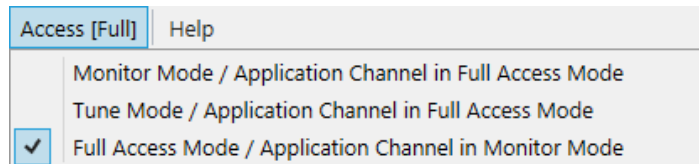

DIAGNOSTIC ACCESS MODES

Monitor Mode

In Monitor Mode, ClearView 3.0, through the Diagnostic Port, can access the Soft Scope. Most other settings and parameters are restricted. **Note:** All restricted UI items will be grayed out in the ClearView 3.0 UI. *The EtherCAT Master has "Full Access" in this mode.*

Tune Mode

In Tune Mode, ClearView 3.0 has access to the Soft Scope and most of the tuning gains, RAS settings, following error limit, and fine tuning controls. *The EtherCAT Port has "Full Access" in this mode.*

Full Access Mode

In Full Access Mode, ClearView 3.0 has full control of the motor, including access to all normally available settings and parameters. *The EtherCAT Master is forced into "Monitor Mode" in this case. Any commands sent by the Master will be ignored.*

TROUBLESHOOTING DIAGNOSTIC PORT CONNECTIONS

If your motors stop communicating with ClearView 3.0, or if you get baud rate errors when connecting or reconnecting to the USB Port, follow these steps:

1. Check that DC Bus Power and Logic Power (if applicable) are present at the motor.
2. Verify that the USB-IR Converter is attached to the motor's IR Port.
3. Check that the motor's USB-IR port is free of dirt and debris.
4. Restart ClearView 3.0

CLEARPATH-EC SOFTWARE REFERENCE

The ClearPath-EC Software Reference Manual is available on the Teknic Downloads page. See link below:

https://tekninc.com/files/downloads/ClearPath-EC_Software_Reference.pdf

APPENDIX A: TROUBLESHOOTING

LED BLINK CODES



**Note: The blue and green Link Activity LEDs shine through the motor's sealing gasket where indicated.*

Link Activity and Status LEDs

Status LED	Motor Status
Green flicker	Motor Enabled
Green solid	Motor Disabled
Yellow blink	Motor in Shutdown
Red blink	Hardware Error

Green Link LED	Blue Link LED	Link Activity Description
On	x	IN Link connected. No activity present.
Flickering	x	IN Link connected. Activity present.
Off	x	IN Link not connected.
X	On	OUT Link connected. No activity present.
X	Flickering	OUT Link connected. Activity present.
X	Off	OUT Link not connected.

APPENDIX B: MECHANICAL REFERENCE

DIMENSIONED DRAWINGS (LINKS)

MOTORS

[NEMA 23 Frame ClearPath-EC Motor \(IP66K/67\)](#)

[NEMA 34 Frame ClearPath-EC Motor \(IP66K/67\)](#)

POWER DISTRIBUTION BOARDS

[POWER4-HUB-S](#)

[POWER4-STRIP-S](#)

ACCESSORIES

[CPMS-USB-IR](#)

[CPM-COVER-USB-5P](#)

MOTOR MOUNTING CONSIDERATIONS

Tip: Teknic recommends mounting the motor such that the IR communication port and status LED are visible and accessible when the motor is mounted to the machine.

- **Do not** mount ClearPath over a heat source such as a deep fryer, heater, or hot exhaust pipe. ClearPath will automatically shut down if its internal temperature exceeds its maximum setting.
- **Do not** mount ClearPath in an unventilated enclosure.
- **Do** allow for at least 1” of space around each ClearPath.
- ClearPath can be fitted with an external accessory fan if desired. See ***Fan Mounting and Cooling*** later in this section for details.

CONNECTING CLEARPATH TO A MECHANICAL SYSTEM

While it's obvious that ClearPath must be connected to a mechanical system to do useful work, it's not always clear just how to connect the motor to the mechanics.

Problems arise when a connecting element (such as a coupling) slips, exhibits excessive backlash, or can not accommodate typical shaft-to-shaft misalignments. Ultimately, the choice of shaft interface or coupling depends on the application, whether a precision positioning stage or a low speed conveyor.

The shaft interface (coupling, pulley, pinion, etc.) must be securely clamped to the shaft with minimum backlash (ideally none). This primary mechanical interface is critical in achieving and maintaining the best possible performance from a servo motion system.

MOTOR CONNECTION: GENERAL TIPS AND GUIDELINES

This section contains information and tips on how to safely and securely couple a servo motor to a mechanical system.

For more information on this topic, visit the Teknic website:

<https://teknic.com/securing-mechanics-motor-shafts/>

- **Align with care.** When connecting two shafts—such as a motor shaft to a screw shaft—the rotating centers must be carefully aligned in both the angular and offset sense (including offsets/adjustments for thermal growth) to achieve the best possible motion quality and longest motor/bearing life.

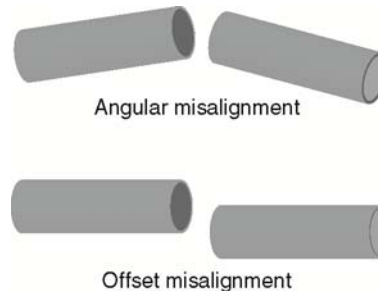

Some couplings are more forgiving of misalignment than others, but in general, misalignment will cause undesired vibration/noise, shortened bearing life, or even broken motor shafts in extreme cases.

- **Use lightweight components.** Aluminum couplings, pinions, and pulleys add significantly less inertia to the motion system than steel parts of the same size. In most applications, lower inertia is preferable because it allows the motor (and attached mechanics) to accelerate harder and move and settle faster.
- **Don't use set screws.** Coupling devices with set screws are prone to failure and often become the weak link when joining a motor to a load. Set screws deform the metal around the screw's point of contact, often resulting in a raised bur on the shaft that can make it hard to remove and replace the coupling element. Set screws also tend to slip and score the shaft.
- **Tip:** Couplings, pulleys and pinions with circumferential clamping mechanisms tend not to damage motor shaft, hold better, and are easier to replace than those that use set screws.
- **Clamp close to the motor.** For maximum performance, secure pulleys and pinions as close to the motor face as is practical. This effectively reduces the lever arm (and associated bearing load) for applications with a side load.
- **Don't over-tension belts.** Always read the belt manufacturer's guidelines for proper belt tension, but never exceed the ClearPath specification for maximum side load. Overly tight belts put undue stress on the motor shaft and bearing systems that can result in premature bearing and shaft failure.

- **Avoid using shaft keys when possible.** Although ClearPath includes a keyway feature on the shaft, Teknic does not generally recommend the use of keys. Keys tend to cause run-out and backlash errors, particularly in reciprocating, precision positioning motion applications.
However, keys *should be considered* for use in applications where coupling slip could result in a dangerous or hazardous condition. Also, key use may be appropriate for unidirectional applications (where the motor always spins in the same direction) as these applications are less prone to key-related lash problems.
- **Avoid direct loads.** In general, ClearPath motors are not designed for connection to direct loads (e.g. direct connection to a grinding wheel). However, direct connection may make sense if the load is of low-mass and balanced, as with small mirrors for laser applications.

NOTES ON COUPLING SELECTION

A complete coverage of the topic *Coupling Selection for Servo Applications* is beyond the scope of this document, but many articles and resources can be found on the web for those interested in learning more. Because there are so many different coupling styles and applications, selecting the “right” coupling for a particular application can be challenging.

For more information on this topic, visit the Teknic website:
<https://teknic.com/securing-mechanics-motor-shafts/>

General Guidelines for Coupling Selection

Teknic has a few guiding principles when it comes to coupling selection for servo applications. Keep in mind that these are rules of thumb and may not apply to every application. In general:

- **Don’t** undersize the coupling. Understand how much torque your application requires and stay within the coupling manufacturers specifications. Always leave reasonable engineering margin.
- **Don’t** use set screw type couplings. They damage the motor shaft and tend to be less reliable over time than clamp style couplings.
- **Do** use clamp style couplings. These clamp around the circumference of the shaft at one or two points without deforming the shaft surface.
- **Don’t** use rigid couplings—they are notoriously intolerant of misalignments.
- **Don’t** use beam style (helical) couplings if vibration damping or torsional stiffness is critical to your application. Beam couplings tend to resonate/whine at higher speeds.
- **Don’t** use any coupling that requires you to drill into, deform, or “pin” the motor shaft.

Coupling Recommendation

Teknic often recommends **zero-backlash curved jaw couplings** (commonly referred to as “spider couplings”) as a good choice for many servo applications. These couplings are moderately priced and widely available from well established manufacturers such as Ruland.



Curved Jaw (Spider) Coupling

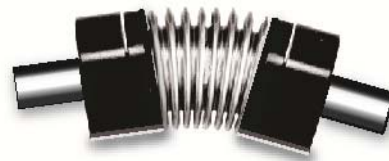

Bellows Coupling

Couplings for servo applications

Note: Curved jaw couplings (also known as spider couplings) are a good choice for many applications, but cannot tolerate a great deal of

misalignment or axial motion. Also, never exceed the manufacturer's rating for "maximum torque with zero backlash" when using jaw couplings.

Bellows couplings are also excellent for high precision positioning applications. Bellows couplings allow for more misalignment than jaw couplings but are generally more expensive.

Both curved jaw and bellows coupling offer excellent positioning accuracy, high speed performance, and vibration damping when installed and operated within the manufacturer's specifications and guidelines.

Coupling Information on the Web

Ruland's website has a good collection of technical information on coupling types and coupling selection for servo systems. See links below.

<https://www.ruland.com/technical-resources/technical-articles>

<https://www.ruland.com/technical-resources/technical-articles/5-reasons-to-consider-using-jaw-couplings>

INSTALLING PULLEYS AND PINIONS

PULLEY AND PINION MOUNTING

- Always follow the manufacturers mounting guidelines.
- Mount pulleys and pinions as close to the motor face as possible while still following the manufacturer's installation guidelines.
- Never drill through, "pin", or deform the motor shaft when mounting a pulley or pinion.

Application Tip: To prevent loose or slipping pulleys and pinions, some customers use Loctite 638 to bond components to the motor shaft. **Note: Loctite 638 is a very strong adhesive.** When fully cured, Loctite 638 can only be removed by applying heat to the bonded parts.

ABOUT END-OF-TRAVEL STOPS

End-of-travel stops are typically installed to prevent the moving element of a linear axis from flying off the machine in the event of a use or control error. There are a few common types of end stop to consider, but the final choice depends on the application objectives and requirements.

HARD BLOCKS

This is usually a solid block of steel, aluminum, or hard plastic secured at one or both ends of travel and positioned in such a way as to allow for even, repeatable contact with the moving element. Hard blocks are effective at arresting motion, but can result in mechanical damage when struck at high speeds.

ELASTOMERIC (RUBBER) STOPS

High durometer rubber stops (hard rubber) can also be used with applications that use HardStop Homing. This type of end stop offers a higher level of shock absorption and axis protection than hard blocks. Spongy, low durometer rubber stops are not recommended in most cases. They offer little benefit over a hard end stop during an axis crash.

PNEUMATIC (DASHPOTS)

Pneumatic hard stops (dashpots) offer excellent shock absorption performance but are considerably more expensive than hard blocks. Examples of specialized dashpots include the hydraulic cylinder in an automobile shock absorber as well as many automatic door closers.

END STOPS AND HARD STOP HOMING

End stops from medium durometer rubber to steel can be used successfully with Hard Stop Homing. When selecting end stops for a Hard Stop Homing application consider the following:

- Axes with low friction that are easily back driven can tolerate “softer” rubber end stops and still achieve good homing performance.
- Higher friction applications and those that cannot be back driven will generally require harder end stop material to achieve best Hard Stop Homing performance.
- Be prepared to test and experiment with different end block materials to ensure proper homing operation with your mechanical system.

FAN MOUNTING (OPTIONAL)

ClearPath motors include unthreaded mounting bosses on the rear casting to accommodate a standard computer fan (60mm for NEMA 34 motors, or 40mm for NEMA23 motors). To attach a fan to these bosses use thread-cutting #6 or M3.5 screws.

Note: Accessory fans are optional and available through electronics suppliers including Digikey and Mouser. External power is required (12VDC or 24VDC typical).

Note: As with all electronic products, *cooler is better* for longest operating life. So even though ClearPath can reliably operate at elevated temperatures (exceeding the ratings of most other motor drives) your system should always be designed with motor thermal considerations in mind.

Note: ClearPath will shut down to self-protect when the rear cover temperature reaches ~80 degrees C.

ClearPath NEMA 34 Designed for 60mm fans rated at 11 CFM or greater

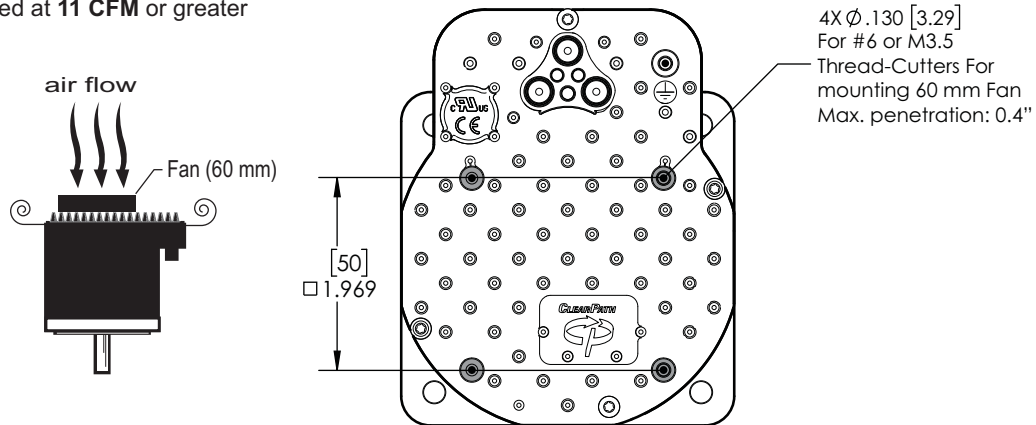

ClearPath NEMA 23 Designed for 40mm fans rated at 5 CFM or greater

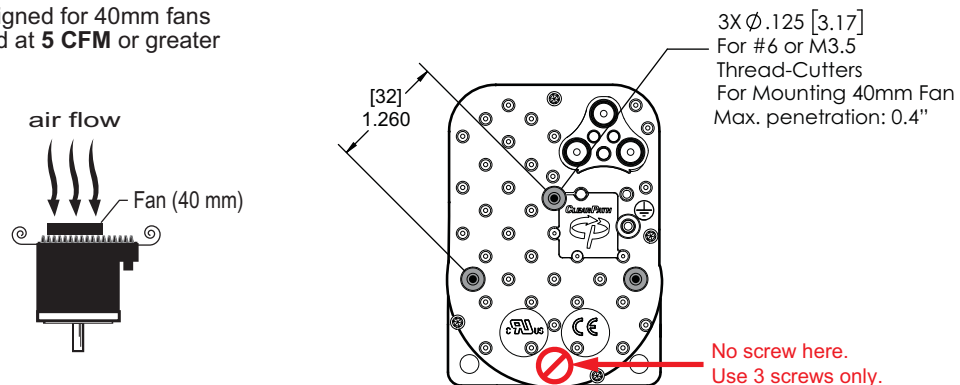

APPENDIX C: CONNECTOR AND CABLE REFERENCE

This section contains part numbers for ClearPath-EC mating connectors, terminals, and tools.

MATING CONNECTORS

POWER4-HUB-S, POWER4-STRIP-S, IPC-5

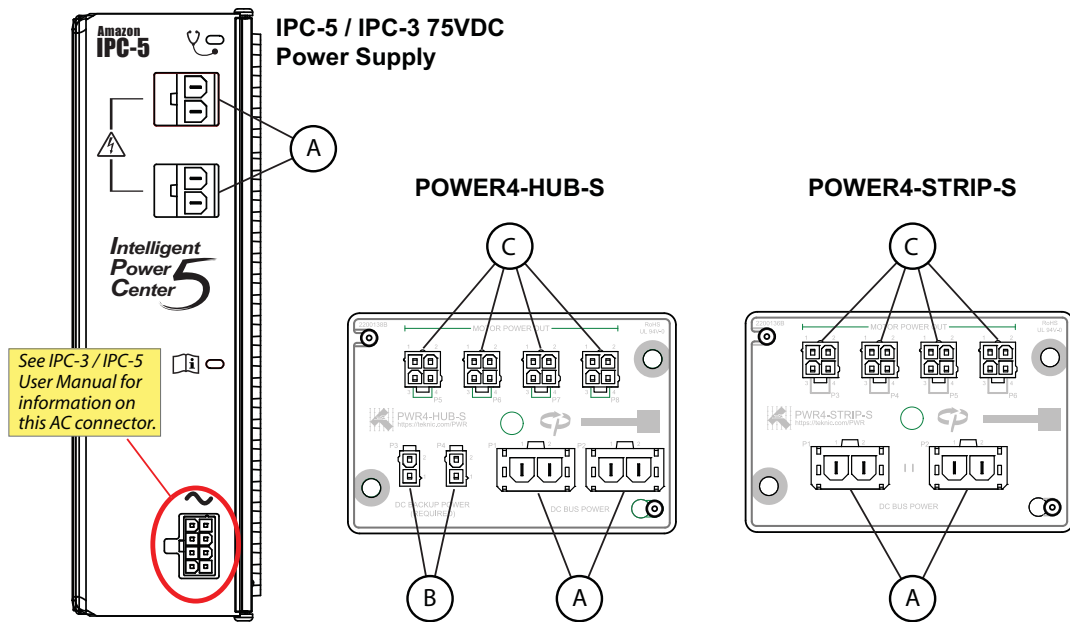

Parts listed in table manufactured by Molex Inc. Visit www.molex.com for complete specifications and application information.

Ref.	Desc.	Mating Connector PN	Terminal PN	Terminal Desc.	Crimp Tool	Extraction Tool	Wire Gauge ¹
A	Molex Sabre, Receptacle, 2 circuits	44441-1002 (natural, UL 94V-2) 44441-2002 (black, UL 94V-0)	43375-0001	Female crimp terminal, tin plate, 14-16 AWG	63811-7200 (14-16 AWG)	63813-2700	16 AWG
B	Molex MiniFit-Jr, Receptacle, 2 circuits	39-01-2020 (natural, UL 94V-2) 39-01-3025 (black, UL 94V-2) 39-01-3028 (natural, UL 94V-0) 39-03-9022 (black, UL 94V-0)	39-00-0059 (reel) 39-00-0060 (loose)	Female crimp terminal, tin plate, 18-24 AWG	63819-0901 (18-24 AWG)	11-03-0044	20 AWG
C	Molex MiniFit-Jr, Receptacle, 4 circuits	39-01-2040 (natural, UL 94V-2) 39-01-3045 (black, UL 94V-2) 39-01-2045 (natural, UL 94V-0) 39-03-9042 (black, UL 94V-0)	39-00-0077 (reel) 39-00-0078 (loose)	Female crimp terminal, tin plate, 16 AWG	200218-2200 (16 AWG)	11-03-0044	16 AWG (Pins 2,3)
			39-00-0046 (reel) 39-00-0047 (loose)	Female crimp terminal, tin plate, 22-28 AWG	63819-1000 (22-28 AWG)		22 AWG (Pins 1,4)

¹AWG values listed are the actual wire gauges used in Teknic-manufactured cables.

M12 ADAPTER (P/N: M12-ENET-CON)

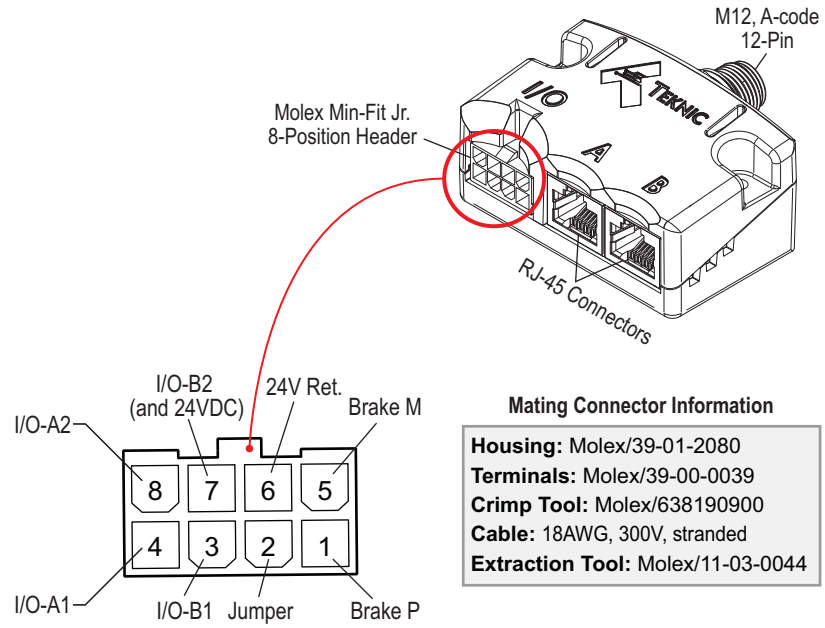

CABLE DRAWINGS (LINKS TO TEKNIC.COM)

[CPMS-CABLE-NET-AA039](#)

[CPMS-CABLE-NET-AA120](#)

[CPMS-CABLE-NET-AA315](#)

[CPM-CABLE-CTRL-MU120](#)

[CPMS-CABLE-PWR-KM120](#)

[CPMS-CABLE-PWR-KK660](#)

[PC-SBR-72](#)

[CPM-CABLE-M2P2P-120](#)

[CPM-CABLE-M4P4P-120](#)

On tightening M12 connectors. For a reliable seal, tighten the communication and power cables between 0.8 Nm-1.4 Nm. **Tip:** When M12 cable connectors are properly tightened there should be no more than 1-2 threads visible on the motor connectors.

APPENDIX D: SPECIFICATIONS

CLEARPATH-EC MOTOR: COMMON SPECIFICATIONS

Functional Specifications

EtherCAT Drive Profile	CiA402 conforms to IEC 61800-7-201; CoE, FoE
EtherCAT vendor ID	0x0C96
Profile modes supported	Synchronous position, synchronous velocity, synchronous torque
Distributed clock function	Included
Homing modes supported	Home to a hard-stop, home to a switch
Position limit modes supported	Software limits (after homing), one limit switch, or two limit switches
Maximum shaft rotational speed	Model dependent; 6,000 RPM mechanical limit
Sensor resolution	Hi res: 51,200 counts per revolution. Low res: 12,800 counts per revolution.
Absolute position sensor function	Implemented by battery backup of the Logic Supply. (A single battery and charger can provide absolute position function for all motors in a machine.)
Digital I/O complement	Two (2) isolated circuits, each independently configurable as input or output
Digital I/O isolation	A and B circuits, each independently galvanically isolated, 500V dielectric strength
Motor sensor position capture response (from input A)	250nS
Brake control (from output B)	Automatic upon disable, safety shutdown, or DC bus removal
Safe Torque Off (STO) functionality	Via DC bus removal by external device, resettable via network command
Safe Stop (SS2-t) functionality	Via DC bus clamp by external device, resettable via network command
Protection modes	Following error shutdown, Bus over-voltage, Bus under-voltage, Bus RMS current limit, Drive instantaneous current limit, Motor RMS current limit (slow + fast), Drive over-temperature, Position sensor fault
Built-in self test	Internal power supply test, Processor clock stability test, Position sensor test, Program memory test, Data memory test, Ethernet PHY I.C. tests

Configuration Port

Physical layer	Full-duplex asynchronous transmission via an infrared light pipe system
IP Protection	Inherent IP67/66K (submersion/washdown) protection
Configuration software functions	Motion monitoring with real-time scope and numerous trigger modes, servo compensator tuning (automatic and manual), fault log display, configuration file load/save, EtherCAT parameter browser/watch window, remote support tools.
Configuration software compatibility	Microsoft Windows 10 or later
IR to USB-C adapter securing method	Magnetic
Mating IR to USB-C converter (required)	Teknic part number: CPMS-USB-IR

Electrical Power Requirements, Motor Bus Supply:

Bus Supply Voltage, Typical:	24VDC to 75VDC
Bus Supply Voltage, Absolute Min:	21.5VDC (as measured at input terminals)
Bus Supply Voltage, Absolute Max:	90VDC (as measured at input terminals)

Continuous Bus Current, Typical:	1A to 4A (application dependent)
Continuous Bus Current, Maximum:	10A
Disabled Power, Maximum	20mW
Enabled Power @ 75V (zero shaft torque)	<1W

Electrical Power Requirements, Logic Supply:

Logic Supply Voltage, Typical:	12 VDC - 75 VDC
Logic Supply Voltage, Absolute Min:	10 VDC (as measured at input terminals)
Logic Supply Voltage, Absolute Max:	90 VDC (as measured at input terminals)
Continuous Logic Power:	2.4W@24V, 2.5W@48V, 3W@75V
Continuous Logic Power, Maximum:	~4W

I/O circuits (A or B) specifications, when used as inputs:

Logic Input Voltage Range:	4.0VDC to 28VDC
Input Current @ 5V:	7.5mA (min.)
Input Current @ 28V:	12.0mA (min.)
Recognition Time, maximum	250nS input A for position capture; 250uS for general use
Inductive clamp voltage	48V
Inductive clamp energy/power rating	200mW

I/O circuits (A or B) specifications, when used as outputs:

Output Absolute Maximum Voltage	30VDC (across output terminals)
Output Current, Maximum:	9mA (non-inductive load)
Output voltage drop @ 2mA:	0.30VDC (+/- 100mV)
Output voltage drop @ 5mA:	0.55VDC (+/- 100mV)
Inductive clamp voltage	48V
Inductive clamp energy/power rating	200mW

Motor Bearing, NEMA34:

Maximum Radial Load, NEMA34:	220N (50-lbs), applied 25mm (1.0in) from front bearing
Maximum Thrust Load, NEMA34:	44N (10-lbs)
Bearing Life, NEMA34:	2.4×10^9 to 5.3×10^9 revs (typ., load dependent.)

Motor Bearing, NEMA23:

Maximum Radial Load, NEMA23:	110N (25 lbs.), applied 25mm (1.0in) from front bearing
Maximum Thrust Load, NEMA23:	22N (5 lbs.)
Bearing Life, NEMA23:	3.2×10^9 to 5.0×10^9 revs (typ., load dependent.)

Environmental:

Shock (peak, maximum):	10G (applied no more than twice)
Vibration (RMS, 2 Hz-200 Hz):	1.0G or 0.5mm, whichever is less
Maximum External Shaft Deceleration:	$250,000 \text{ rad/s}^2$
Operational Ambient Temperature ¹ :	-40°C to +70°C
Storage temperature	-40°C to +70°C
Maximum Body Temp.:	100°C
Maximum Rear Cover Temp.:	80°C
Humidity:	0% to 100%
Optional Fan (user-supplied), NEMA23:	40mm square, 45.25 mm bolt center, >= 5 CFM
Optional Fan (user-supplied), NEMA34:	60mm square, 70.71 mm bolt center, >= 11CFM

Environmental Sealing:

Motor with properly engaged, watertight connectors and optional shaft seal:	IP66K/IP67 Note: Front flange <i>without</i> optional shaft seal is IP53 rated.
---	--

Compliance (CE, UL):

Drive Electrical and Thermal Safety:	EN 61800-5
Electrical Interference (EMI)	EN 61800-3
Electrical Machine Rating (motor core)	EN 61034-1 (UL1004)
Ingress Protection (sealing)	EN 61034-5
Materials used within	RoHS, REACH, Conflict Minerals

Country of Origin:

USA

Warranty:

3 years

¹The RMS torque limit on certain motors is derated for operation in ambient temperatures above +40°C. Contact Teknic for derating assistance.

POWER4-HUB-S

DC Bus Motor Power (Input from DC Bus Motor Supply)

Nominal voltage range	24VDC to 75VDC
Max. input voltage	100VDC
Max. continuous current	20A
Peak current (3 seconds)	50A
Connectors	2-pin Molex Sabre (P1, P2)

Logic Power (Input from Logic Power Backup Supply)

Nominal voltage range (touch-safe)	12VDC to 42VDC
Max. input voltage	100 VDC
Max. continuous current	10A
Max. peak current	10A
Connectors	2-pin Molex MiniFit Jr. (P3, P4)

DC Bus Motor Power (Output to ClearPath motors)

Max. motors	4
Connectors	4-pin Molex MiniFit Jr. (P1, P2, P3, P4)

Dielectric Withstand Voltage

Between DC Bus and Backup Power	1,600 VDC
Between DC Bus and chassis plate	1,600 VDC
Between Backup Power and chassis plate	1,600 VDC

Environmental

Operating temperature**	-40°C to +70°C
Long term storage temperature	-40°C to +50°C
Pollution Degree	2

Dimensions

L x W x H (w/o baseplate)	3.37" x 2.23" x 0.67"
L x W x H (with baseplate)	3.62" x 2.35" x 1.03"

Country of Origin

USA

Warranty

1 year

**For operation over 40°C refer to power derating data

POWER4-STRIP-S

DC Bus Motor Power (Input from DC Bus Motor Supply)

Nominal voltage range	24VDC to 75VDC
Max. input voltage	100VDC
Max. continuous current	20A
Peak current (3 seconds)	50A
Connectors	2-pin Molex Sabre (P1, P2)

DC Bus Motor Power (Output to ClearPath motors)

Max. motors	4
Max. continuous current	10A
Peak current (3 seconds)	20A
Connectors	4-pin Molex MiniFit Jr. (P1, P2, P3, P4)

Environmental

Operating temperature**	-40°C to +70°C
Long term storage temperature	-40°C to +50°C
Pollution Degree	2

Dielectric Withstand Voltage

Between DC Bus and chassis plate	1,600 VDC
----------------------------------	-----------

Dimensions

L x W x H (w/o baseplate)	3.37" x 2.23" x 0.67"
L x W x H (with baseplate)	3.62" x 2.35" x 1.03"

Country of Origin

USA

Warranty

1 year

**For operation over 40°C refer to power derating curves in this manual

APPENDIX E: GROUNDING AND SHIELDING

PROTECTIVE EARTH (PE) CONNECTION

Compliance Note: ClearPath must be properly connected to the machine's Protective Earth terminal to meet EMC emissions/immunity specification EN-61800-3, as well as electrical safety specification EN-61010 (for CE/UL compliance).

Connect ClearPath to your machine's Protective Earth terminal (PE) using one of the following methods.

- **If the motor mounting plate is bonded to machine PE (typical)**, most of the work is already done. Simply secure ClearPath to the mounting plate with conductive fasteners (don't use anodized or coated hardware). Ensure direct, bare metal-to-metal contact between the ClearPath motor face and mounting surface.
- **If the motor mounting plate is *not* bonded to machine PE** it's still easy to make a good PE connection. Just install a grounding wire from ClearPath's Auxiliary PE Connection Point (located on the motor's rear casting) to a point on the machine that is bonded to machine PE. **Use #6-32, thread forming screw, 5/16" length** (McMaster-Carr PN 93878A145). Use grounding wire with same AWG number (or heavier) as the ClearPath DC power input wiring.

Note: In scenarios where ClearPath *is not* connected to a PE (Protective Earth) return path—such as during bench testing or maintenance—temporary grounding measures may be necessary to comply with safety requirements.

GROUNDING AND SHIELDING

- Always maintain separation between isolated control ground and power ground.
- Shielded cable is not required for ClearPath control cables.
- If you choose to use shielded control cable, connect the cable's isolated ground at one point (at the controller only). Do not hook isolated control ground to the machine frame or chassis at any other location.
- Do not ground ClearPath I/O circuits to the machine frame or chassis.

Note: All ClearPath I/O signals are electrically isolated from ClearPath's DC power input and motor output circuits, as well as from the motor case. This design feature helps to ensure that control signals aren't compromised by induced currents from the motor, power supply, or internal PWM.

POWER RETURNS

- Never use the machine frame or chassis as a power return. Use discrete cable or wires for all power wiring.
- Use only recommended wire gauge (16-18AWG typical) for all ClearPath power wiring. When in doubt, use heavier wire.

APPENDIX F: CLEARPATH PART KEY



1	Product ID	CPM	ClearPath® Motor
2	Family/Model	ECSK	EtherCAT Compatible / Stepper Killer
		ECHP	EtherCAT Compatible / High Power
3	Motor Frame Size	23	NEMA 23 frame
		34	NEMA 34 frame
4	Body Length <i>Approximate, excludes shaft length</i>	1	NEMA 23: 91mm NEMA 34: 84mm
		2	NEMA 23: 110mm NEMA 34: 103mm
		3	NEMA 23: 129mm NEMA 34: 122mm
		4	NEMA 23: 148mm NEMA 34: 141mm
5	Winding/Magnetic Structure	0	Indicates specific winding design. See your motor's torque-speed curve for more information.
		1	
		2	
		5	
		6	
6	Winding Type	H	Series-Wye (higher torque, lower speed)
		F	Parallel-Wye (in between H and J characteristics)
		J	Parallel-Delta (higher speed, lower torque)
7	Enhanced Options	R	Regular Positioning Resolution = 12,800 counts per revolution
		E	Enhanced Positioning Resolution = 51,200 counts per revolution
8	Shaft Diameter	L	Standard diameter (NEMA 34 = 1/2" dia., NEMA 23 = 3/8" dia.)
		Q	1/4" shaft diameter (<i>available only on NEMA 23 models with body length 1 or 2</i>)
9	Shaft Seal	N	Standard dust sealing
		S	Additional PTFE infused polyimide seal. Not available on 1/4" shaft models.
10	Feature Set	B	Standard features.

APPENDIX G: M12 ADAPTER SCHEMATIC

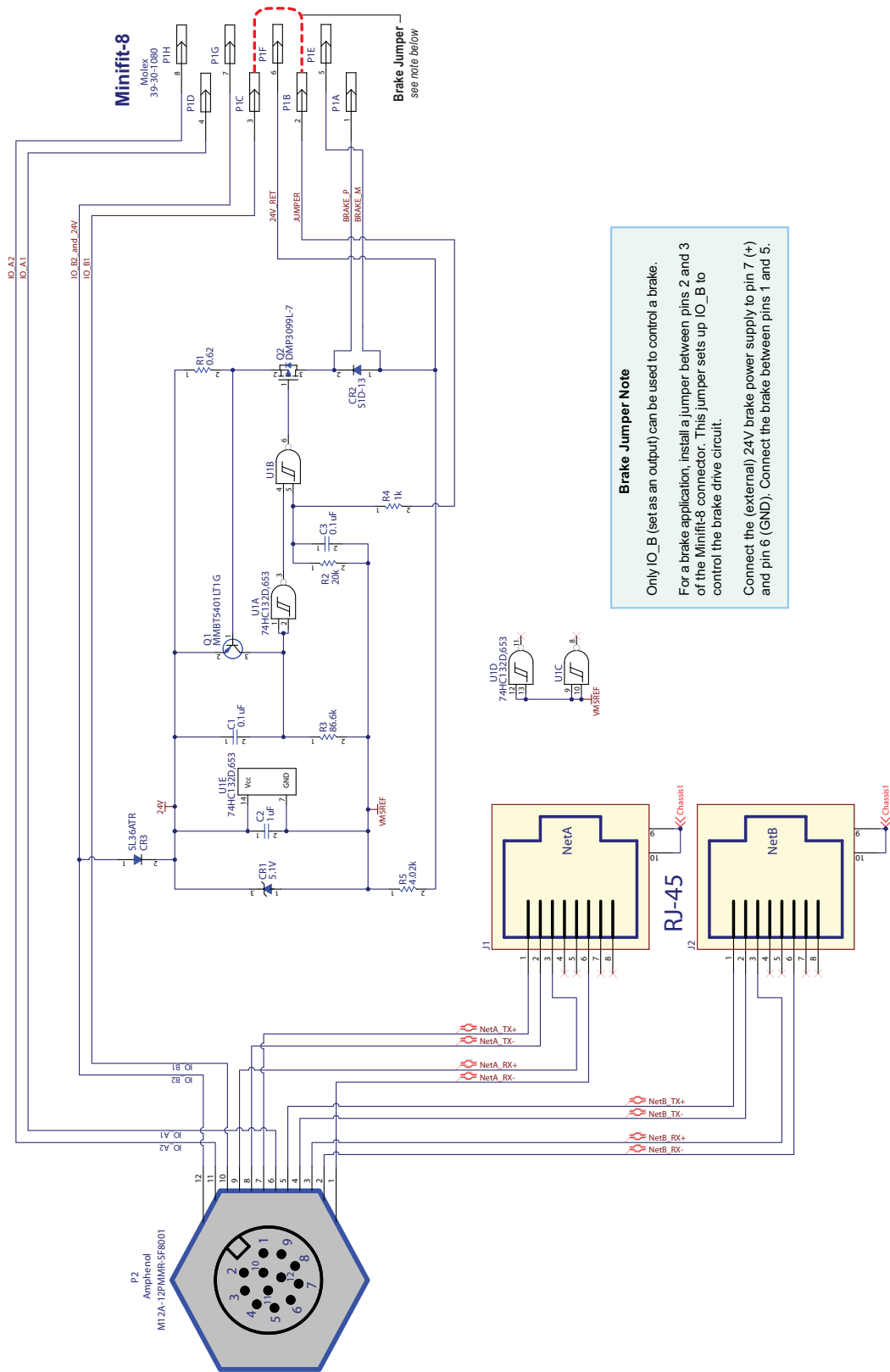

APPENDIX H: CABLES FOR CONTINUOUS-FLEX APPLICATIONS

Continuous-flex applications can present a challenge when it comes to selecting ClearPath-EC control cables appropriate for use with a cable carrier. The main challenge: most off-the-shelf cables don't combine all of the required characteristics into one integrated cable.

This document describes several approaches to cable selection and routing for ClearPath-EC cable carrier applications.

The *ideal* control cable would combine three characteristics:

- Continuous-flex construction (i.e., suitable for cable carriers)
- Support for EtherCAT's high-speed communication (a critical attribute as reliable system operation depends on maintaining the network's high-speed data transmission performance)
- Twelve conductors to carry network *and* I/O signals in a single cable (only 8 conductors are required if not using the M12 Adapter's I/O capability)

Ultimately, the best cabling solution depends on placement of the M12 Network Connector Adapter and whether the Adapter's I/O complement is used.

CASE 1: MOTOR I/O IS NOT USED (SIMPLEST CONFIGURATION)

Option A – M12 Adapter located *after* the cable carrier

- Route a continuous-flex Cat6 (or better) cable through the cable carrier and connect to the M12 Adapter using standard RJ45 connectors. See figure below.
- The M12 Adapter's I/O connector can be left unpopulated.

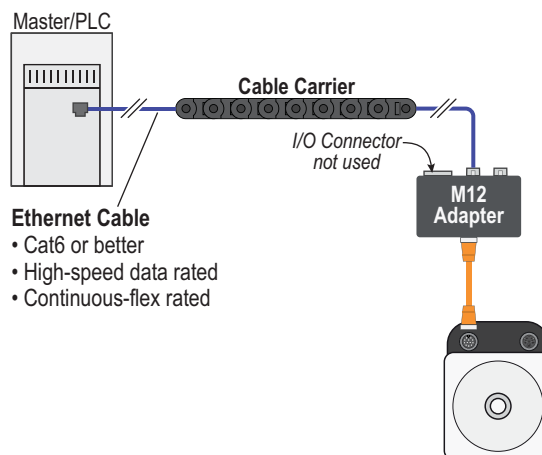

Note: Do not mount the M12 Adapter in wet or dirty environments unless it is bulkhead-mounted or the RJ45 connector side is fully protected from exposure to liquids, sprays, and particulate.

Option B – M12 Adapter located *before* the cable carrier

- Route a Cat6 (or better) cable from the master to the M12 Adapter.
- Terminate both ends with M12 A-coded female connectors to create an 8-conductor continuous-flex cable assembly.
- The M12 Adapter’s I/O connector can be left unpopulated.

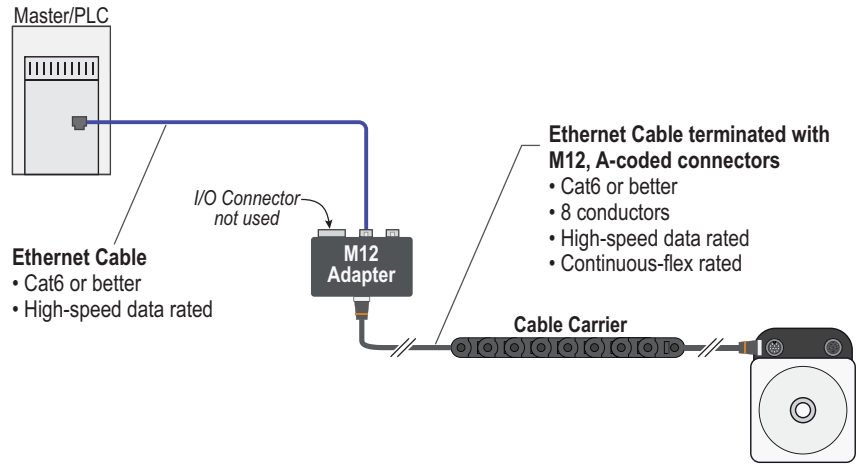

CASE 2: MOTOR I/O IS USED

Option A – M12 Adapter located *after* the cable carrier

- Place the Adapter close to the motor and route the Ethernet cable through the cable carrier.
- Run an off-the-shelf (OTS) continuous-flex Cat6 (or better) cable with RJ45 connectors through the cable carrier.
- Connect field devices (I/O) to the Adapter’s Molex 8-pin I/O connector according to the user manual.

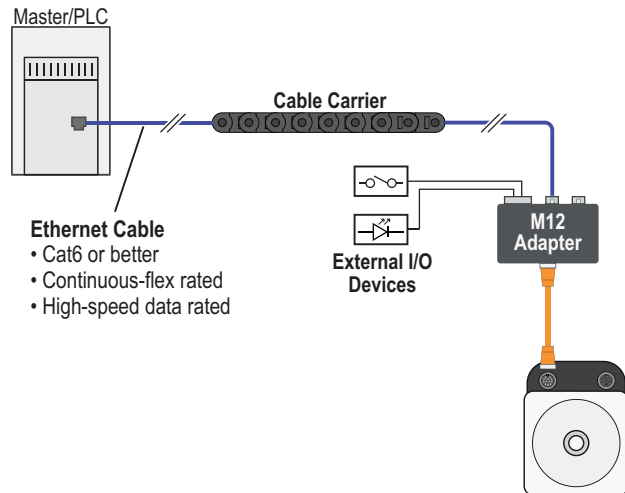

Option B — M12 Adapter located *before* the cable carrier

- Route a Cat6 (or better) cable from the master to the M12 Adapter.
- Terminate both ends with M12 A-coded female connectors, creating an 8-conductor continuous-flex cable assembly.
- Run continuous-flex I/O wiring through the cable carrier and terminate the Molex 8-pin connector per the user manual.

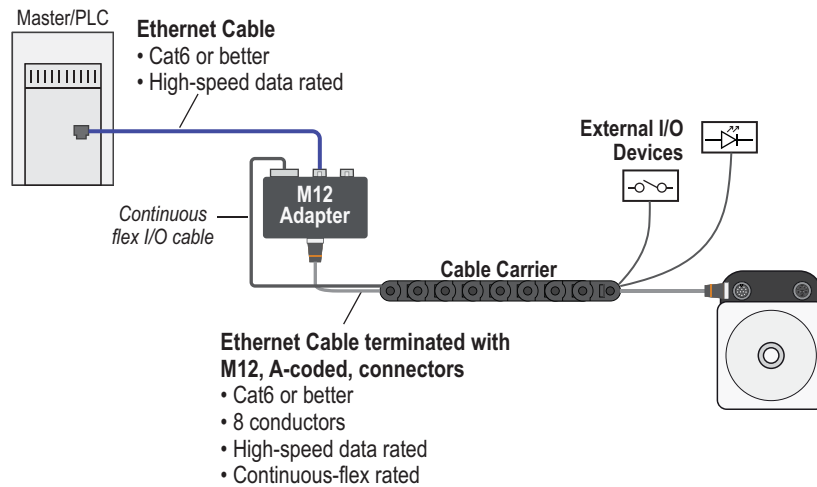
**ETHERCAT CABLING CONSIDERATIONS**

EtherCAT does not employ a ring topology for data transmission. By design, a single Cat6 cable carries bidirectional communication between devices, which can simplify installation, particularly when the M12 Adapter is located after the cable carrier.

Important Some manufacturers do offer 12-conductor I/O cables that may *appear* to be suitable for flex applications. However, *unless a cable is explicitly rated for high-speed data communication, it should not be assumed to support EtherCAT's communication requirements.*

Teknic does not recommend specific Cat6 continuous-flex cables because the most suitable cable solution depends on application-specific factors such as:

- Bend radius requirements
- Cable fill within the cable carrier
- Environmental conditions
- Other installation constraints

Note: Continuous-flex Cat6 cables in a wide range of lengths are widely available from cable suppliers and resellers.

APPENDIX I: MISCELLANEOUS

HOW TO MAKE A LOGIC POWER SUPPLY CABLE FOR YOUR POWER4-HUB-S

This section describes how to make an inexpensive, no-crimps-required cable to connect your Logic Power Supply to a POWER4-HUB-S.

Notes:

- Most users choose a Logic Power Supply of 12VDC or 24VDC, *but the ClearPath-EC motor will work with any Logic Supply between 12-75VDC.*
- The minimum power requirements of a logic power supply depends on application requirements.

Instructions

1. Select a Logic Power Backup Supply. Typically 12V or 24V, but can be any voltage from 12V-75V.
2. Order a Teknic [CPM-CABLE-M2P2P-120](#). This is a 120" (10-ft.), 2-pin Molex to 2-pin Molex cable as shown below.

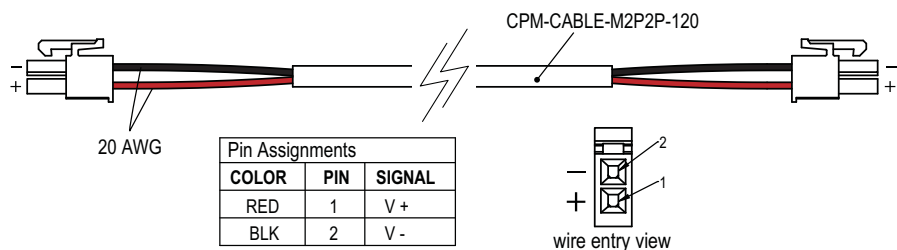

CPM-CABLE-M2P2P-120

3. Cut the cable to the desired length. If you cut it exactly in half, you can make two five foot cables.
4. Strip the outer jacket and conductors on the unterminated end of the cable to create flying leads.
5. Connect the flying leads to your Logic Power backup supply. Insulate any exposed conductors with heat shrinkable tubing, electrical tape or similar.

Test DC output polarity before connecting. Use a DMM to verify proper polarity at the DC output connector. Use the above diagram as a reference.

OTHER PRODUCT NOTES

RE: ELECTRICAL FAST TRANSIENT (EFT) TESTING

Electrical fast transient testing might induce a motor communication error. In such an event, the motor will come to a controlled stop. The communication error can be cleared by a node reset, after which motion can be resumed on command.

CLEARPATH EMC INSTRUCTIONS

<https://teknich.com/files/downloads/ClearPath EMC Instructions.pdf>

Teknic, Incorporated
7650 Omnitech Pl
Victor, NY 14564

© 2026 TEKNIC INCORPORATED, ALL RIGHTS RESERVED