

# INSTALLATION AND USE GUIDE

## AMAZON IPC-75 INTELLIGENT POWER CENTER

THIS DOCUMENT DOES NOT COVER MODELS IPC-3 AND IPC-5

VERSION 1.87 / DECEMBER 12, 2025

**THIS PAGE INTENTIONALLY LEFT BLANK**

# TABLE OF CONTENTS

TABLE OF CONTENTS .....	3
INTRODUCTION .....	4
What is the Amazon Intelligent Power Center?.....	4
The bottom line .....	4
SAFETY .....	5
General Precautionary Statement.....	5
Symbols Used in this Manual .....	5
SYSTEM OVERVIEW .....	6
Amazon IPC Operation .....	6
MECHANICAL INSTALLATION .....	8
Mounting Orientation and Clearance Requirements .....	8
Mounting Options .....	9
Mounting the IPC Using the Rear Mounting Holes .....	10
Mounting the IPC From the Front.....	11
Protective Earth Grounding Requirements.....	12
ELECTRICAL INSTALLATION.....	13
Pilot Power .....	13
AC Input Circuit .....	14
Plug Selection .....	14
Cable / Conductor Selection .....	14
Circuit Breaker and Contactor Selection .....	15
AC Input Harness.....	16
Drive Power Request Signal (DPR) .....	17
Power-Up Sequence and Timing .....	18
Power-Down Cycle .....	18
Removing DC Output Power .....	18
Emergency Power-Down (E-Stop) .....	19
DC Output Connector (P5).....	19
Expansion Connector (P6).....	20
APPENDIX A: IPC CABLE DRAWINGS .....	21
DC Output Cable .....	21
AC Input Cable: 90-250VAC Single Phase/Three Phase .....	22
AC Input Cable: 5-Wire, Three Phase.....	23
APPENDIX B: IPC CONNECTOR REFERENCE .....	24
APPENDIX C: LED STATUS CODES .....	26

# INTRODUCTION

---

## WHAT IS THE AMAZON INTELLIGENT POWER CENTER?

At its core, the Amazon Intelligent Power Center (IPC) is a DSP-managed power supply that delivers clean, stout power to 300 volt DC-powered servo drives. But the Amazon IPC is more than just a power supply.

### **Amazon IPC Standard Features:**

- Three AC line options
  - Single-phase, 90-250VAC (208-240 VAC nominal)
  - Three-phase, 90-250VAC (208-240 VAC nominal)
  - 5-wire (155-415VAC) three-phase (360-415VAC nominal)
- Power regeneration management
- Input contactor control
- Over-voltage and over-current protection
- Automatic bus power dump
- Active brake clamping

---

## THE BOTTOM LINE

The Amazon IPC is a complete power solution. It outputs high quality DC power, eliminates expensive, bulky transformers, and provides the power management structure that you, as a machine builder, would otherwise have to design, build, and install yourself. What's more, the Amazon IPC provides these features in a compact, well-engineered unit for about the same cost as the "pile of parts" it replaces.

# SAFETY

---

## GENERAL PRECAUTIONARY STATEMENT

Always follow appropriate safety precautions when installing and applying a power supply. Equipment should be designed and utilized to prevent personnel from coming into contact with moving parts and electrical contacts that could potentially cause injury or death. Read all cautions, warnings and notes before attempting to operate or service power supplies and motion control devices. Follow all applicable codes and standards when using this equipment. Failure to apply this equipment as described may impair or neutralize protections built into the product.

---

## SYMBOLS USED IN THIS MANUAL

The following symbols and conventions are used on the equipment and in this manual. Please read all equipment labels and manuals before attempting to use Amazon IPC power supplies.

### Caution, risk of danger



Identifies information about practices or circumstances that can lead to equipment damage, personal injury, or loss of life.

### Shock hazard



Identifies presence of hazardous electrical voltages and currents.

### Protective earth terminal



Indicates points that must be connected to a reliable earth system for safety compliance. Protective earth connections should never be omitted.



**Earth ground terminal**



**Frame or chassis terminal (shield)**



**Direct current**

### Note



Identifies information that is critical for successful application and understanding of the product.

### Tip



Identifies additional information that may be helpful in supporting certain applications.

## SYSTEM OVERVIEW

The figure below shows an Amazon IPC powering two Eclipse DC servo drives from a 3-phase, 210VAC source. Note: the IPC can also operate from single phase 90-250VAC, and 5-wire 155-415VAC (European power). Switching from one type of AC line input to another involves changing the AC input harness and a few external components<sup>1</sup>.

### Amazon IPC nominal AC input voltages:

- 208-240VAC for single and 3-phase (US)
- 360-415 VAC for 3-phase 5-wire (European)

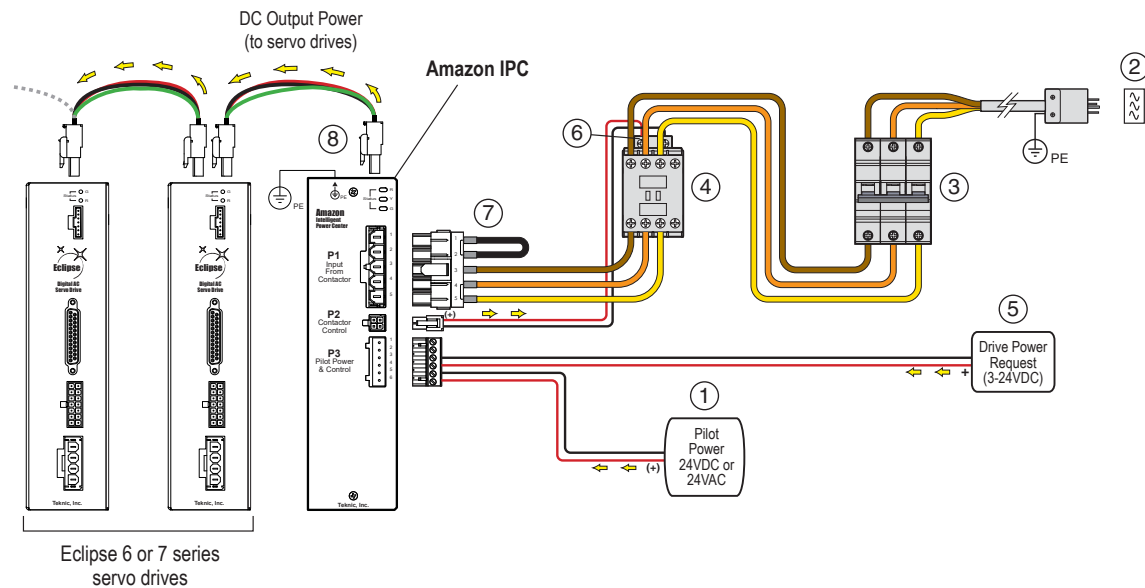

**Amazon IPC system (three-phase, 210VAC shown)**

## AMAZON IPC OPERATION

The following is an abbreviated description of operation for the Amazon IPC system pictured above. Greater detail on individual components, connectors, and wiring is provided throughout the manual and in the appendices.

To begin with, Pilot Power [1] must be applied at connector P3. Pilot Power serves two purposes in the IPC: 1) it supplies voltage to the DSP and internal logic circuits and 2) it is used to energize the contactor coil. The IPC cannot power up or operate without Pilot Power.

Line power from the AC source [2] passes through the circuit breaker [3] to the contactor [4].

To power up the DC bus, the Drive Power Request (DPR) signal [5] must be asserted. The 3-24VDC DPR signal can come from an unused controller output, or it can be a simple power supply and rocker switch.

<sup>1</sup> This may include the contactor, breaker, cable, and/or plug, depending on your AC line power.

When the DPR signal is asserted, the IPC connects 24VDC or 24VAC Pilot Power<sup>2</sup> to the contactor coil [6] through P2.

When the contactor coil is energized, main AC voltage passes through the contactor and AC input cable [7] into the IPC at connector P1. The IPC then begins its main DC output power-up cycle. A soft start circuit prevents nuisance circuit breaker trips during this phase.

The IPC then runs a self diagnostic. If no faults are detected, The IPC releases full output power to the DC output connector P5 [8]. If a fault is detected, the IPC performs a safety shutdown.<sup>3</sup> The power-up cycle takes 2 seconds to complete (after the DPR signal is asserted).

From P5, DC power is distributed to any connected servo drives. Teknic Eclipse 6xx and 7xx servo drives require a single, inexpensive cable to carry DC power from drive to drive. See Appendix A for cable drawings.



**Shock Hazard:** Hazardous voltage is present at P5 and P6 immediately after the contactor closes. Treat these contacts and circuits as hazardous at all times.

---

<sup>2</sup> The type of voltage (24VAC or 24VDC) depends on Pilot Power and contactor selected.

<sup>3</sup> Under certain rare circumstances (e.g. the main contacts weld shut) hazardous energy could remain on the DC bus despite the IPC's attempt to remove power.

# MECHANICAL INSTALLATION

Follow these important guidelines to ensure that your Amazon IPC is mounted correctly. This section covers the following topics:

- Mounting orientation and clearance requirements
- Mounting options, hardware, and tools
- Grounding requirements

## MOUNTING ORIENTATION AND CLEARANCE REQUIREMENTS

- **Mounting Orientation** - Mount the Amazon IPC vertically against a metal surface to achieve maximum power output and component life. Never mount the IPC upside down. Inverting the device will reduce or eliminate the internal fan's cooling capacity, and may lead to thermal problems.

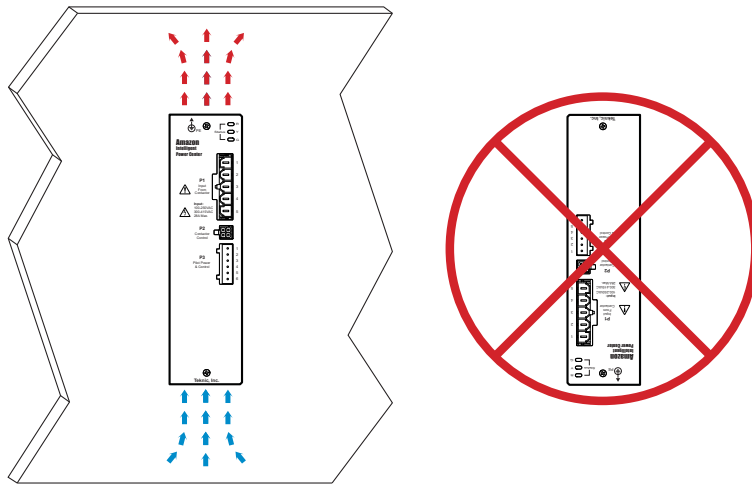

### Approved mounting orientation for Amazon IPC

- **Mounting the Amazon IPC near servo drives** - If the IPC is to be mounted in an enclosure with servo drives, mount the units as shown in the figure on next page. It is also acceptable to mount the IPC above the servo drives.

**Note:** Never mount the IPC below servo drives or other heat sensitive devices. This can force hot air into the servo drive enclosure which can reduce drive output and cause thermal shutdowns.

- **Minimum spacing and clearance guidelines** - Follow the minimum spacing guidelines (see figure on next page) to ensure proper airflow.

**Note:** Failure to follow minimum spacing requirements may lead to reduced output capacity and thermal failure.

- **Environmental considerations** – The Amazon IPC is rated for indoor use in a pollution degree 2 or cleaner environment. The IPC is rated for operation in ambient temperatures between 0°-40°C and at relative humidity of 0-95% (non-condensing).

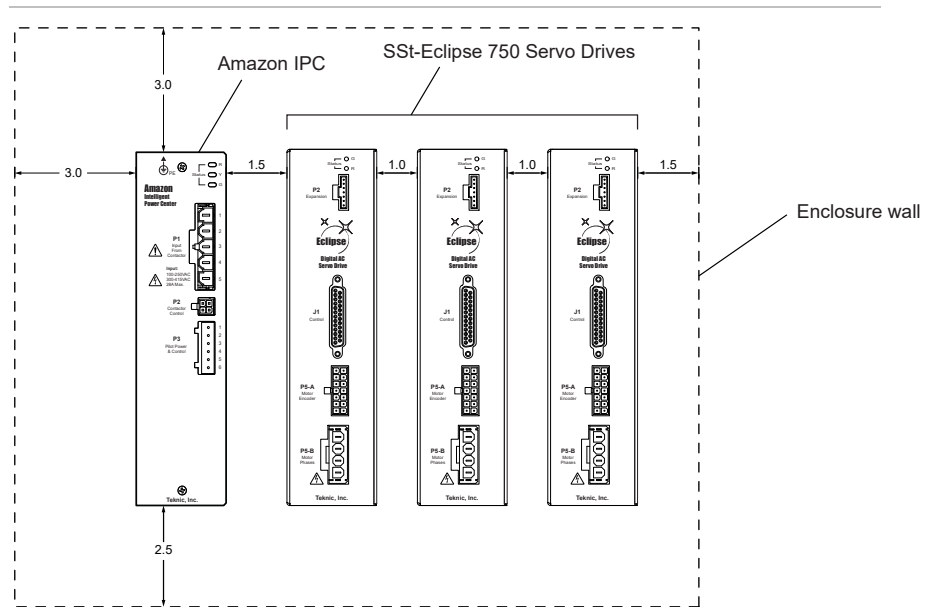

**Minimum spacing requirements for Amazon IPC with servo drives**

## MOUNTING OPTIONS

There are two approved methods for mounting the Amazon IPC:

1. **Rear mounting holes** - Fasten the Amazon IPC to a panel or cabinet from behind using two (2) size #10-32 screws. Limit screw length to 0.5 inch maximum penetration into the chassis. Refer to the mounting diagrams for other important details.
2. **Mounting flanges** - Mount The Amazon IPC from the front using the mounting flange slots on the sheet metal case. Refer to the mounting diagrams for important details.

Detailed Mounting diagrams for these two methods appear on the following pages. Carefully read the section on grounding before installing this product.

**Note:** The drive mounting surface should be a clean, uncoated metal surface. An unpainted, uncoated cabinet or backplane is ideal. Mounting screws should be an electrically conductive material such as stainless steel. Avoid anodized mounting screws. If the mounting surface is painted, a star washer or external tooth lock washer may provide sufficient electrical continuity.

**Note:** The machine’s protective earth connection must connect to the mounting surface for the IPC, servo drives, and motors.

**Caution:** The power supply and drive enclosure should be designed to prevent an end user from accessing the IPC and Eclipse drives when hazardous power is applied.



### MOUNTING THE IPC USING THE REAR MOUNTING HOLES

Using this mounting method, install your Amazon IPC into a panel or cabinet using the two rear mounting holes as shown below. **Important:** limit the screw length so that no more than 1/2" of the screw extends into the Amazon IPC case.

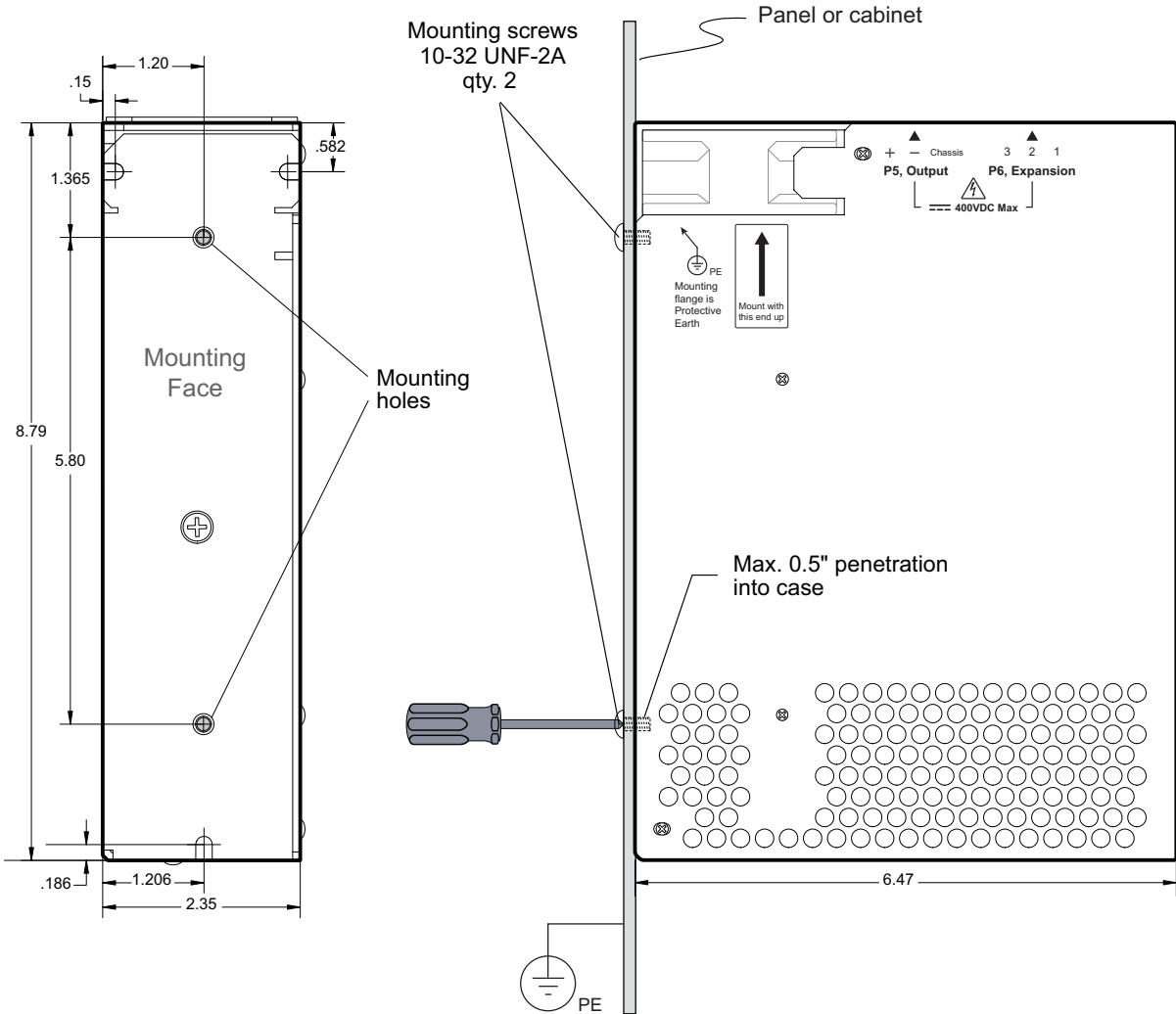

**Amazon IPC panel or cabinet mounting using rear mounting method**

## MOUNTING THE IPC FROM THE FRONT

The Amazon IPC has three mounting flange slots cut into the chassis to facilitate front access mounting. Use three #10-32 socket head cap screws and a 5/32" ball nose Allen driver.



**Note:** When front-mounting the Amazon IPC, be sure to leave adequate space around the unit for tool clearance. A long, ball nose Allen driver is required as the mounting flanges are located in recessed positions on the chassis (to minimize the IPC's footprint). Follow the minimum spacing guidelines ([page 9](#)) to ensure adequate tool clearance.

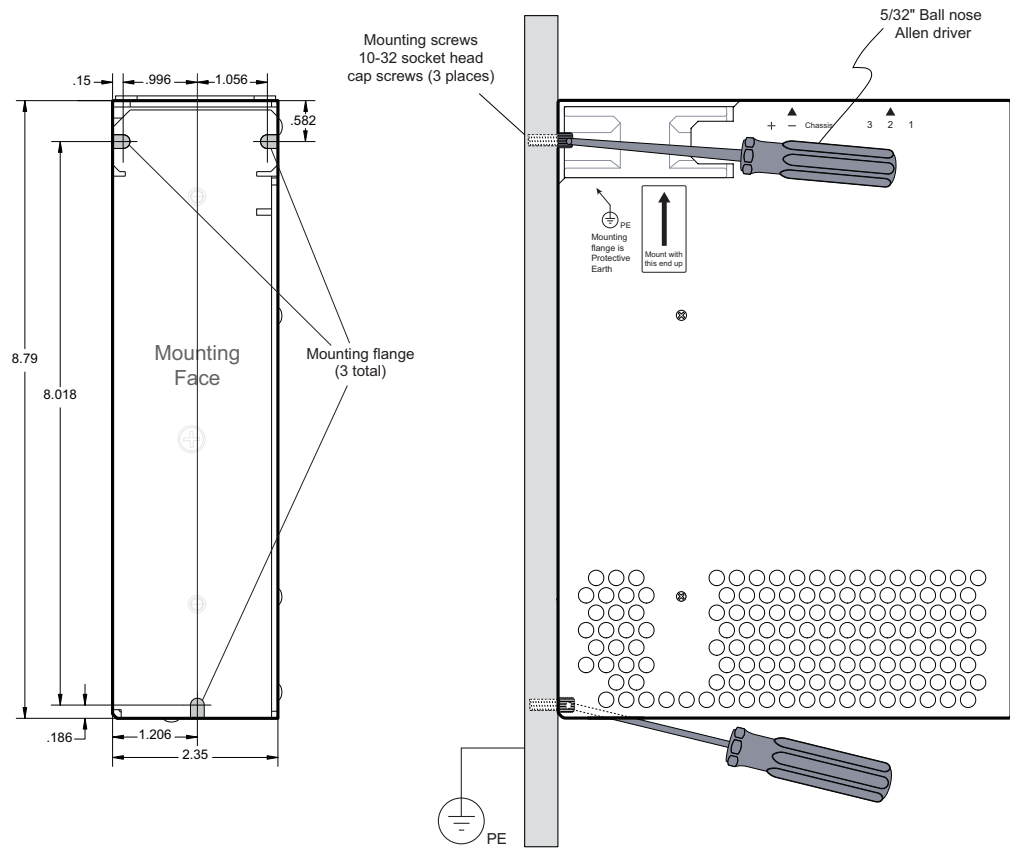

**Mounting the Amazon IPC using the front mounting method**

## PROTECTIVE EARTH GROUNDING REQUIREMENTS

For safe, reliable operation, your Amazon IPC *must* be bonded to Protective Earth Ground. The sections below explain IPC Protective Earth grounding requirements.



**Note:** Failure to properly ground the IPC will result in operational problems.

**If the panel or cabinet is properly bonded to Protective Earth Ground**, the IPC mounting screw holes (or flanges for front mounted units) will connect the IPC chassis to Protective Earth. Be sure to use uncoated screws and clean threads (no paint or anodize) when securing the IPC to the mounting panel.

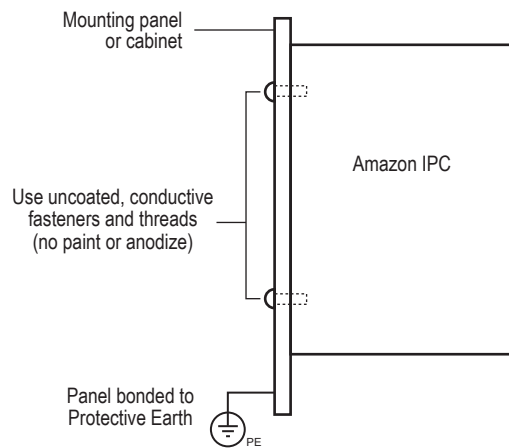

### **Grounding when panel/cabinet is bonded to Protective Earth**

**If the panel or cabinet is not bonded to Protective Earth Ground**, use the #10-32 threaded insert located on the top surface of the Amazon IPC to connect the unit to PE ground. Refer to the figure below for important details.

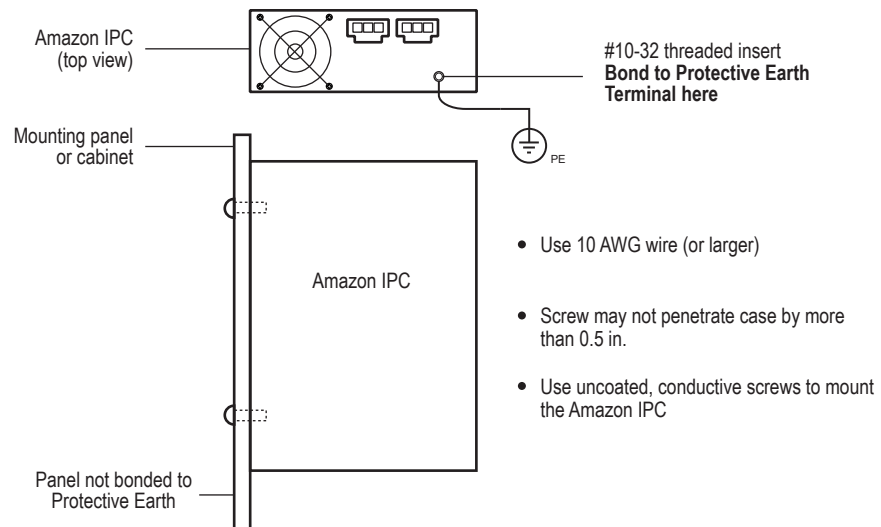

### **Grounding when panel/cabinet is not bonded to Protective Earth**

# ELECTRICAL INSTALLATION

This section addresses the Amazon IPC electrical installation. Topics discussed in the section include:

- Pilot Power
- AC Input Circuit
- Drive Power Request (DPR) Signal
- DC Output

## PILOT POWER

Pilot Power must be present at connector P3 before the Amazon IPC can operate. Pilot Power is a user-supplied 24VDC or 24VAC @ 1 amp power supply that serves two purposes in the IPC:

- 1) It powers the IPC’s onboard logic (DSP and other logic devices).
- 2) It supplies the voltage required to energize the contactor coil.

The figure below illustrates the dual functionality of Pilot Power in the Amazon IPC.

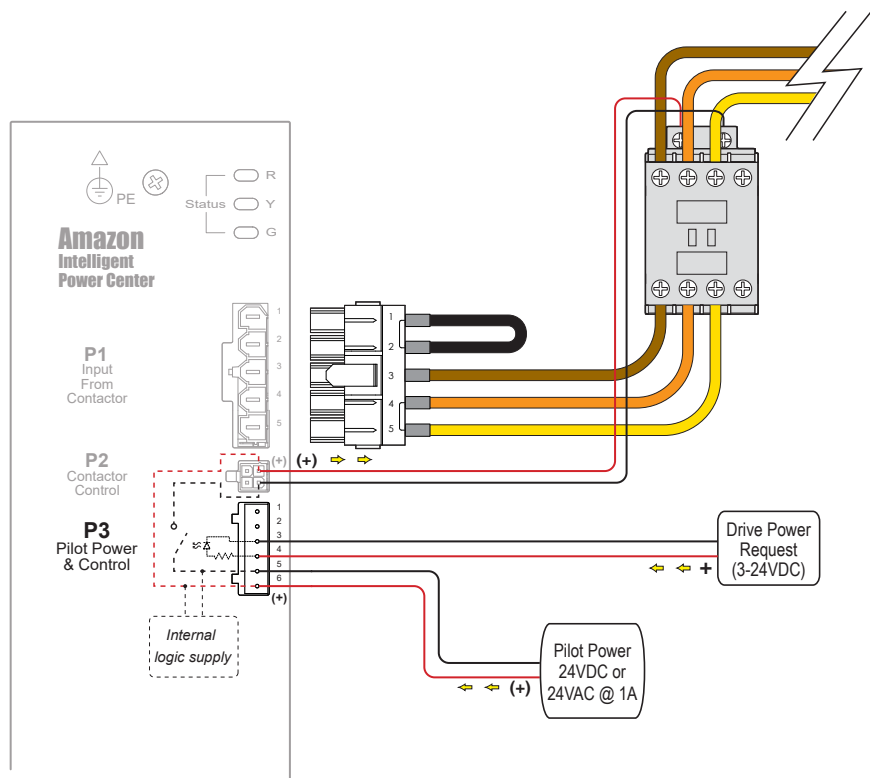

### Pilot Power circuit



**Note:** The Pilot Power supply type (AC or DC) must be consistent with the contactor type, i.e. a 24VDC Pilot Power supply must be paired with a 24VDC contactor, and a 24VAC Pilot Power supply requires a contactor with a 24VAC coil.



**Note:** The approved DC contactors (see table 2) are the non-polarized type (i.e. you can reverse the leads and the unit will still work). If you select a polarity sensitive DC contactor, follow the polarity markings shown in the previous figure and in Appendix B.

## AC INPUT CIRCUIT

For convenience and flexibility, The Amazon IPC can accept AC line input from the following sources:

- Single phase, 90-250VAC
- Three phase, 90-250VAC
- 5-wire (155-415VAC)

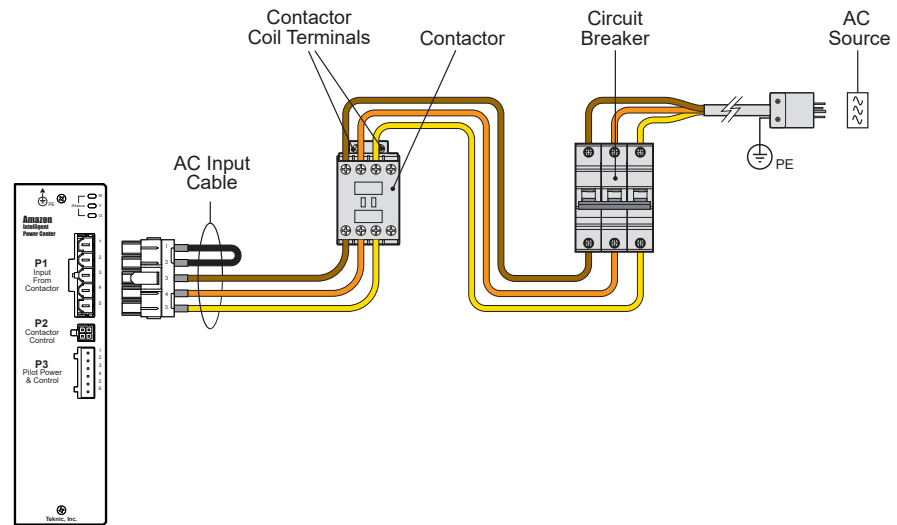

*AC input path (Three phase configuration shown)*

## PLUG SELECTION

This is a user-defined component. Select a plug appropriate for the power requirements of your project and local electrical codes.

## CABLE / CONDUCTOR SELECTION

The recommended cable is rated for 600 volts minimum with stranded 10 AWG conductors.

### CIRCUIT BREAKER AND CONTACTOR SELECTION

Refer to the Table 1 for circuit breaker and contactor selection data. Select a circuit breaker with a tripping delay characteristic similar to that shown in the figure below.

	IPC-75	Units
Power Out nominal	6000	Watts
Voltage Out nominal	300	Volts DC
DC continuous current	20	Amps DC
AC input circuit breaker	25	Amps AC

**Table 1 - Input/output power, voltage, and current**

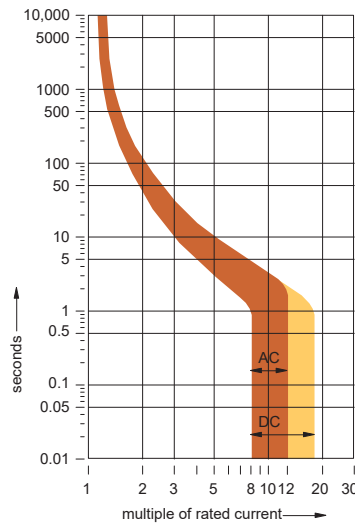

**Graph of typical circuit breaker trip delay characteristic**

Teknic has tested and approved the following contactors for use with the Amazon IPC:

	IPC-75
Manufacturer	Sprecher & Schuh
Contact Configuration	3 NO + 1 NC
Part Number (24VDC coil)	CA7-23C-01-24D
Part Number (24VAC coil)	CA7-23-01-24Z

**Table 2 - Recommended contactors**



**Note:** The contactor coil power output is protected by a self-resetting over-current device rated at 0.75A continuous.

**Note for 5-wire (155-415VAC) users:** Electrical code in some localities requires that contactors used in 5-wire power systems must break the neutral wire. In this case, the contactor would require three normally open contacts + neutral.

## AC INPUT HARNESS

The **AC Input harness** is comprised of two cables 1) the **AC Input cable**, which runs from the contactor output to the AC input connector P1, and 2) the **Contactor Control cable** which runs from the contactor coil to connector P2.

Teknic manufactures three AC Input harnesses (see figure below). Select the harness appropriate for your AC power source. Complete drawings for these harnesses appear in the appendix.

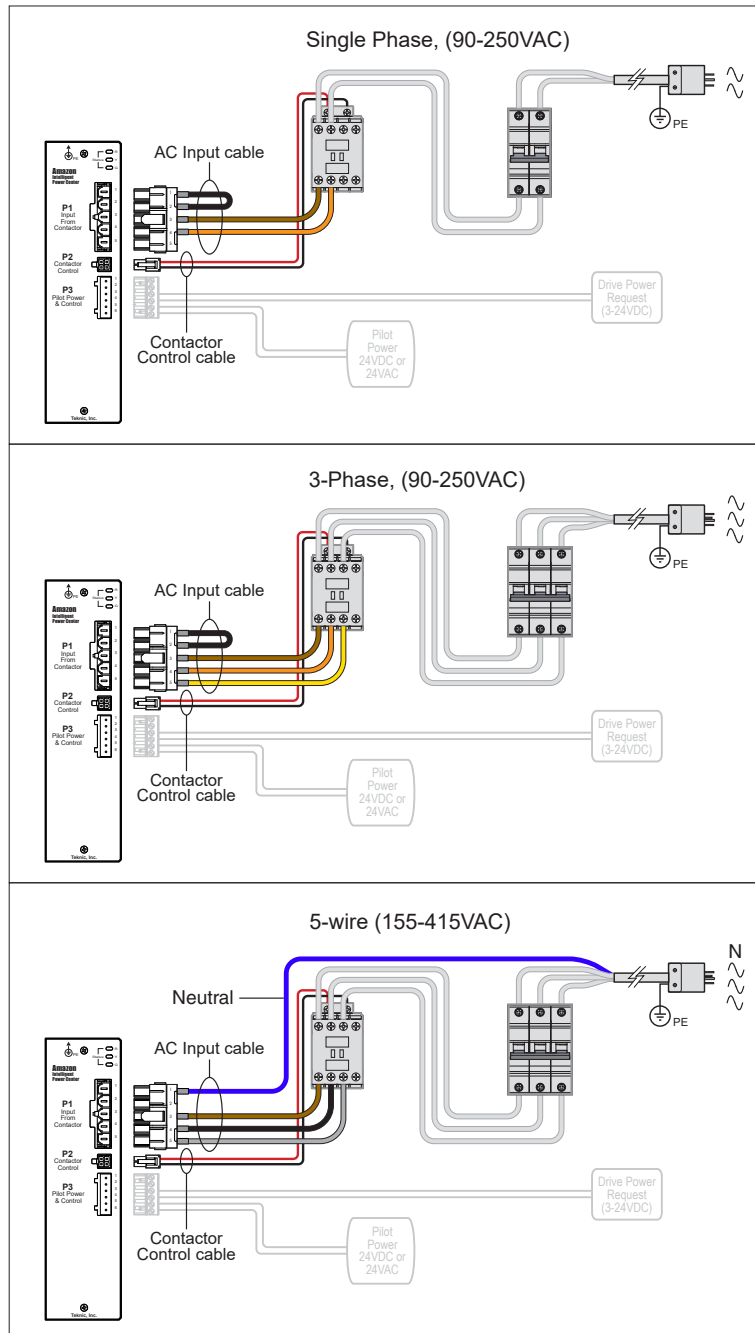

**AC Input harness options**



**Shock Hazard:** Never connect or disconnect servo drives from the Amazon IPC DC output bus when power is applied. Doing so may result in electric shock to the operator and electrical arcing that may damage components connected to the system.

## DRIVE POWER REQUEST SIGNAL (DPR)

The **Drive Power Request (DPR)** signal acts as the Amazon IPC’s DC output on/off switch. The user provides this 3-24VDC signal to pins 3 and 4 on connector P3.

The Drive Power Request signal can originate from a controller output, or it can be something more manual, such as a DC power supply/rocker switch combination. Refer to Table 3 for Drive Power Request voltage and current requirements.

Drive Power Request Voltage	Min. Current
3VDC	2mA
5VDC	4mA
12VDC	12mA
24VDC	24mA

**Table 3 - Drive Power Request voltage and current requirements**

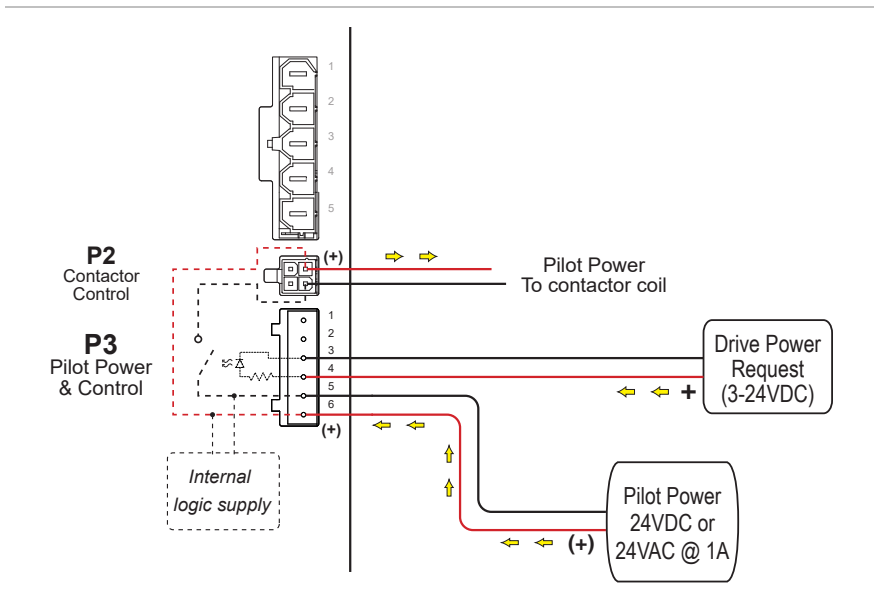

**Drive Power Request and Pilot Power operation**

## POWER-UP SEQUENCE AND TIMING

The DPR signal operates as described by the timing diagram and steps listed below.

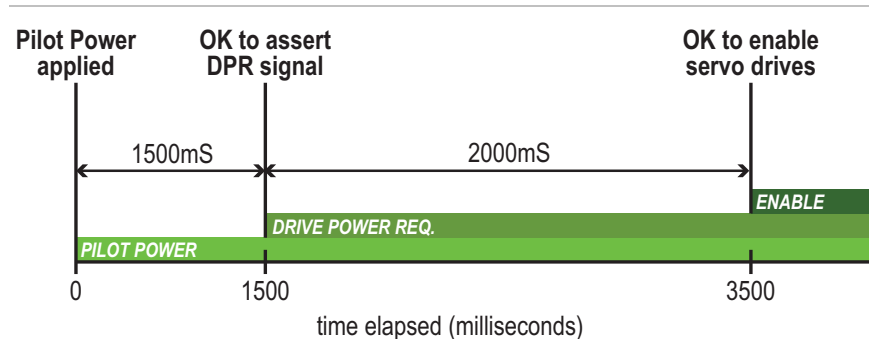

### Power-up timing (minimum timing between events)

1. Pilot Power must be applied a minimum of 1500mS before the DPR signal is asserted.
2. The DPR signal is asserted by the operator. The DPR voltage turns on an optocoupler LED within the IPC (see figure above).
3. The optocoupler LED signals the Drive Power Request to the DSP. The DSP then checks the status of the supply. If the status is OK, the DSP turns on an internal relay (the relay associated with the Pilot Power circuit) providing an internal path for Pilot Power from P3 to P2.
4. Pilot Power (now present at P2) energizes the contactor coil.
5. The contactor closes and main AC input power is released to P1. This initiates the main DC Output power-up cycle.
6. As long as no faults are detected by the IPC, full DC power is released to P5 (the DC Output connector) 2000mS after the DPR signal is asserted.
7. At this point, the DC bus is fully powered and any connected servo drives may be enabled.



**Note:** Pilot Power must be present at P3 for at least 1500mS before the Drive Power Request signal is asserted to ensure that the Amazon's DSP is fully booted.



**Shock Hazard:** Asserting the Drive Power Request signal, when Pilot Power is on and AC Input power is present at the contactor input, will (by design) energize the contactor coil, sending hazardous DC voltage to P5 and all connected downstream servo drives.

## POWER-DOWN CYCLE

### REMOVING DC OUTPUT POWER

To remove DC output voltage from the IPC (and all connected servo drives) turn off the DPR signal. This initiates the DC output power-down cycle causing the main contactor to open and discharge all stored DC bus energy to an internal dump resistor.

Under normal operating conditions the IPC and servo drives are fully discharged and safe to handle 5 seconds after the DPR signal is removed. Do not remove pilot power until the DC bus dump is complete (i.e. wait 5 second at least).

**EMERGENCY POWER-DOWN (E-STOP)**

During an E-stop event, main power to the IPC is immediately interrupted. It is advisable to design any E-stop implementation such that it automatically turns off the DPR signal as well.



**Note:** In order to power-up the IPC after an E-stop or other power interruption, you must de-assert (turn off) the DPR signal and follow the power-up sequence as described earlier in this section. If the DPR signal is asserted before (or at the same time as) the Pilot Power voltage, *the IPC will not power up*. The unit will immediately go into a self-protection shutdown mode. Follow the proper power-up sequence to clear the shutdown.

**DC OUTPUT CONNECTOR (P5)**

P5 is the DC output connector. When AC power is available at P1 and the contactor coil is energized, the nominal DC output voltage will be present on this connector. See the appendix for a detailed DC output cable drawing. The DC output connector (P5) cannot be accessible when the Amazon IPC is powered on.

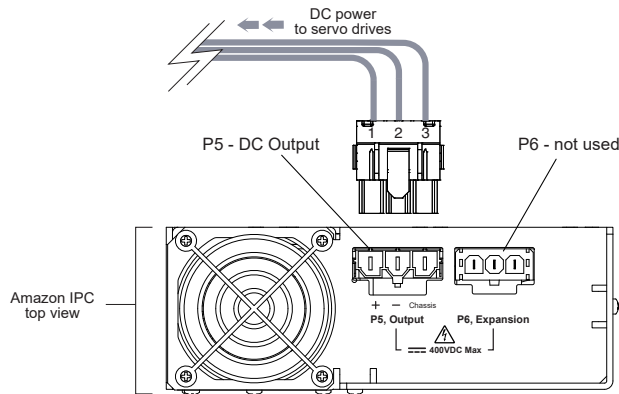

**DC output connector P5**



**Note:** The “rigid test finger”—a test tool recognized by both UL and EN-61010-1—can touch the electrical contacts when P5 is not populated with a mating connector. This is also true of the motor power connectors on the E6xx/7xx servo drives. This does not present a hazard or compliance issue provided the final machine design prevents operator access to the IPC and servo drives when power is applied.

---

## EXPANSION CONNECTOR (P6)

Expansion connector P6 is reserved for future use; make no connection to it.



**Shock Hazard:** Hazardous voltage is present on P5 and P6 whenever DC output power is on.

# APPENDIX A: IPC CABLE DRAWINGS

## DC OUTPUT CABLE

**WIRE ENTRY VIEW**

1 RED  
2 BLK  
3 GRN

1 RED  
2 BLK  
3 GRN

**WIRE ENTRY VIEW**

81.5  
2  
2  
.235

**J1, J2 ASSIGNMENTS**

COLOR	PIN	SIGNAL
RED	1	V+
BLACK	2	V-
GRN	3	CHASSIS

**BREAK OFF AND ASSEMBLE AS SHOWN AFTER INSTALLING TERMINALS**

**POSITION HEATSHRINK AS SHOWN AND SHRINK BEFORE INSTALLING TERMINALS 6 PLACES**

**BILL OF MATERIALS**

ITEM	PART NUMBER	DESCRIPTION	QTY
1	ALPHA/3080-3	WIRE, 12 AWG, 600V, RED	1
2	ALPHA/3080-2	WIRE, 12 AWG, 600V, BLK	1
3	ALPHA/3080-4	WIRE, 12 AWG, 600V, GRN	1
4	MOLEX/42815-0312	CONNECTOR, HOUSING	2
5	MOLEX/42815-0114	TERMINAL, SOCKET	6
6	PANDUIT/PLTM-C	CABLE TIE 4"	2
7	3M/VFP-876	TUBING Ø1/4" BLK	6

**REVISIONS**

REV.	DESCRIPTION	DATE
A	INITIAL RELEASE	1/30/2008

**TEKnic, Incorporated**  
Rochester, NY 14534 USA

This document and related electronic files are the sole property of Teknic, Incorporated. It is submitted in confidence. Any duplication or use without written permission is prohibited.

All dimensions are in inches unless otherwise noted.

Third-Angle Projection

Interpret Geometric Tolerances per ASME Y14.5-2009. Unnoted dimensions are basic.

Drawn By: drafter  
File Name: dc7\_12g\_8  
ECO # : 0  
ECO Description: ECO Prototype

Drawn Date: 11/8/2007  
Smed Date: 1/30/2008

TITLE: **DC BUS CABLE, AMAZON/ECLIPSE**

DWG. NO./REV: **DC7-12G-8/A**

1 of 1 Pages

1

# AC INPUT CABLE: 90-250VAC SINGLE PHASE/THREE PHASE

Notes:

1. For items 6-13 (wires) an alternative manufacturer and/or part number may be used so long as all attributes listed in the description are met or exceeded.

J1 Assignment	Signal
1	BLK
2	BLK
3	BRN
4	ORN
5	TE

Wire Entry View

J2 Assignments

Pin	Color	Signal
1	RED	COIL +
2	BLK	COIL -
4	W/O	AUX +

BREAK OFF AND ASSEMBLE AS SHOWN AFTER INSULATING TERMINALS

POSITION HEATSHRINK AS SHOWN AND SHRINK BEFORE INSTALLING TERMINALS

1.00  
.25

12.0±.5  
24.0±.5

11  
5  
6  
14  
7  
8

3 WH  
1 RED  
2 BLK  
4 W/O

1 BLK  
2 BLK  
3 BRN  
4 ORN  
5 YEL

J1 Assignment

Pin	Color	Signal
1	BLK	BLK
2	BLK	BLK
3	BRN	BRN
4	ORN	ORN
5	TE	TE

J2 Assignment

Pin	Color	Signal
1	RED	COIL +
2	BLK	COIL -
4	W/O	AUX +

1.00  
.25

12.0±.5  
24.0±.5

11  
5  
6  
14  
7  
8

3 WH  
1 RED  
2 BLK  
4 W/O

1 BLK  
2 BLK  
3 BRN  
4 ORN  
5 YEL

J1 Assignment

Pin	Color	Signal
1	BLK	BLK
2	BLK	BLK
3	BRN	BRN
4	ORN	ORN
5	TE	TE

J2 Assignment

Pin	Color	Signal
1	RED	COIL +
2	BLK	COIL -
4	W/O	AUX +

1.00  
.25

12.0±.5  
24.0±.5

11  
5  
6  
14  
7  
8

3 WH  
1 RED  
2 BLK  
4 W/O

1 BLK  
2 BLK  
3 BRN  
4 ORN  
5 YEL

J1 Assignment

Pin	Color	Signal
1	BLK	BLK
2	BLK	BLK
3	BRN	BRN
4	ORN	ORN
5	TE	TE

J2 Assignment

Pin	Color	Signal
1	RED	COIL +
2	BLK	COIL -
4	W/O	AUX +

1.00  
.25

12.0±.5  
24.0±.5

11  
5  
6  
14  
7  
8

3 WH  
1 RED  
2 BLK  
4 W/O

1 BLK  
2 BLK  
3 BRN  
4 ORN  
5 YEL

J1 Assignment

Pin	Color	Signal
1	BLK	BLK
2	BLK	BLK
3	BRN	BRN
4	ORN	ORN
5	TE	TE

J2 Assignment

Pin	Color	Signal
1	RED	COIL +
2	BLK	COIL -
4	W/O	AUX +

1.00  
.25

12.0±.5  
24.0±.5

11  
5  
6  
14  
7  
8

3 WH  
1 RED  
2 BLK  
4 W/O

1 BLK  
2 BLK  
3 BRN  
4 ORN  
5 YEL

J1 Assignment

Pin	Color	Signal
1	BLK	BLK
2	BLK	BLK
3	BRN	BRN
4	ORN	ORN
5	TE	TE

J2 Assignment

Pin	Color	Signal
1	RED	COIL +
2	BLK	COIL -
4	W/O	AUX +

1.00  
.25

12.0±.5  
24.0±.5

11  
5  
6  
14  
7  
8

3 WH  
1 RED  
2 BLK  
4 W/O

1 BLK  
2 BLK  
3 BRN  
4 ORN  
5 YEL

J1 Assignment

Pin	Color	Signal
1	BLK	BLK
2	BLK	BLK
3	BRN	BRN
4	ORN	ORN
5	TE	TE

J2 Assignment

Pin	Color	Signal
1	RED	COIL +
2	BLK	COIL -
4	W/O	AUX +

1.00  
.25

12.0±.5  
24.0±.5

11  
5  
6  
14  
7  
8

3 WH  
1 RED  
2 BLK  
4 W/O

1 BLK  
2 BLK  
3 BRN  
4 ORN  
5 YEL

J1 Assignment

Pin	Color	Signal
1	BLK	BLK
2	BLK	BLK
3	BRN	BRN
4	ORN	ORN
5	TE	TE

J2 Assignment

Pin	Color	Signal
1	RED	COIL +
2	BLK	COIL -
4	W/O	AUX +

1.00  
.25

12.0±.5  
24.0±.5

11  
5  
6  
14  
7  
8

3 WH  
1 RED  
2 BLK  
4 W/O

1 BLK  
2 BLK  
3 BRN  
4 ORN  
5 YEL

J1 Assignment

Pin	Color	Signal
1	BLK	BLK
2	BLK	BLK
3	BRN	BRN
4	ORN	ORN
5	TE	TE

J2 Assignment

Pin	Color	Signal
1	RED	COIL +
2	BLK	COIL -
4	W/O	AUX +

1.00  
.25

12.0±.5  
24.0±.5

11  
5  
6  
14  
7  
8

3 WH  
1 RED  
2 BLK  
4 W/O

1 BLK  
2 BLK  
3 BRN  
4 ORN  
5 YEL

J1 Assignment

Pin	Color	Signal
1	BLK	BLK
2	BLK	BLK
3	BRN	BRN
4	ORN	ORN
5	TE	TE

J2 Assignment

Pin	Color	Signal
1	RED	COIL +
2	BLK	COIL -
4	W/O	AUX +

1.00  
.25

12.0±.5  
24.0±.5

11  
5  
6  
14  
7  
8

3 WH  
1 RED  
2 BLK  
4 W/O

1 BLK  
2 BLK  
3 BRN  
4 ORN  
5 YEL

J1 Assignment

Pin	Color	Signal
1	BLK	BLK
2	BLK	BLK
3	BRN	BRN
4	ORN	ORN
5	TE	TE

J2 Assignment

Pin	Color	Signal
1	RED	COIL +
2	BLK	COIL -
4	W/O	AUX +

1.00  
.25

12.0±.5  
24.0±.5

11  
5  
6  
14  
7  
8

3 WH  
1 RED  
2 BLK  
4 W/O

1 BLK  
2 BLK  
3 BRN  
4 ORN  
5 YEL

J1 Assignment

Pin	Color	Signal
1	BLK	BLK
2	BLK	BLK
3	BRN	BRN
4	ORN	ORN
5	TE	TE

J2 Assignment

Pin	Color	Signal
1	RED	COIL +
2	BLK	COIL -
4	W/O	AUX +

1.00  
.25

12.0±.5  
24.0±.5

11  
5  
6  
14  
7  
8

3 WH  
1 RED  
2 BLK  
4 W/O

1 BLK  
2 BLK  
3 BRN  
4 ORN  
5 YEL

J1 Assignment

Pin	Color	Signal
1	BLK	BLK
2	BLK	BLK
3	BRN	BRN
4	ORN	ORN
5	TE	TE

J2 Assignment

Pin	Color	Signal
1	RED	COIL +
2	BLK	COIL -
4	W/O	AUX +

1.00  
.25

12.0±.5  
24.0±.5

11  
5  
6  
14  
7  
8

3 WH  
1 RED  
2 BLK  
4 W/O

1 BLK  
2 BLK  
3 BRN  
4 ORN  
5 YEL

J1 Assignment

Pin	Color	Signal
1	BLK	BLK
2	BLK	BLK
3	BRN	BRN
4	ORN	ORN
5	TE	TE

J2 Assignment

Pin	Color	Signal
1	RED	COIL +
2	BLK	COIL -
4	W/O	AUX +

1.00  
.25

12.0±.5  
24.0±.5

11  
5  
6  
14  
7  
8

3 WH  
1 RED  
2 BLK  
4 W/O

1 BLK  
2 BLK  
3 BRN  
4 ORN  
5 YEL

J1 Assignment

Pin	Color	Signal
1	BLK	BLK
2	BLK	BLK
3	BRN	BRN
4	ORN	ORN
5	TE	TE

J2 Assignment

Pin	Color	Signal
1	RED	COIL +
2	BLK	COIL -
4	W/O	AUX +

1.00  
.25

12.0±.5  
24.0±.5

11  
5  
6  
14  
7  
8

3 WH  
1 RED  
2 BLK  
4 W/O

1 BLK  
2 BLK  
3 BRN  
4 ORN  
5 YEL

J1 Assignment

Pin	Color	Signal
1	BLK	BLK
2	BLK	BLK
3	BRN	BRN
4	ORN	ORN
5	TE	TE

J2 Assignment

Pin	Color	Signal
1	RED	COIL +
2	BLK	COIL -
4	W/O	AUX +

1.00  
.25

12.0±.5  
24.0±.5

11  
5  
6  
14  
7  
8

3 WH  
1 RED  
2 BLK  
4 W/O

1 BLK  
2 BLK  
3 BRN  
4 ORN  
5 YEL

J1 Assignment

Pin	Color	Signal
1	BLK	BLK
2	BLK	BLK
3	BRN	BRN
4	ORN	ORN
5	TE	TE

J2 Assignment

Pin	Color	Signal
1	RED	COIL +
2	BLK	COIL -
4	W/O	AUX +

1.00  
.25

12.0±.5  
24.0±.5

11  
5  
6  
14  
7  
8

3 WH  
1 RED  
2 BLK  
4 W/O

1 BLK  
2 BLK  
3 BRN  
4 ORN  
5 YEL

J1 Assignment

Pin	Color	Signal
1	BLK	BLK
2	BLK	BLK
3	BRN	BRN
4	ORN	ORN
5	TE	TE

J2 Assignment

Pin	Color	Signal
1	RED	COIL +
2	BLK	COIL -
4	W/O	AUX +

1.00  
.25

12.0±.5  
24.0±.5

11  
5  
6  
14  
7  
8

3 WH  
1 RED  
2 BLK  
4 W/O

1 BLK  
2 BLK  
3 BRN  
4 ORN  
5 YEL

J1 Assignment

Pin	Color	Signal
1	BLK	BLK
2	BLK	BLK
3	BRN	BRN
4	ORN	ORN
5	TE	TE

J2 Assignment

Pin	Color	Signal
1	RED	COIL +
2	BLK	COIL -
4	W/O	AUX +

1.00  
.25

12.0±.5  
24.0±.5

11  
5  
6  
14  
7  
8

3 WH  
1 RED  
2 BLK  
4 W/O

1 BLK  
2 BLK  
3 BRN  
4 ORN  
5 YEL

J1 Assignment

Pin	Color	Signal
1	BLK	BLK
2	BLK	BLK
3	BRN	BRN
4	ORN	ORN
5	TE	TE

J2 Assignment

Pin	Color	Signal
1	RED	COIL +
2	BLK	COIL -
4	W/O	AUX +

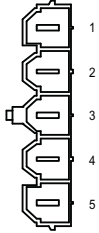

# APPENDIX B: IPC CONNECTOR REFERENCE

P1 - 3-Phase AC Input	Pin#	Signal	Mate
 <p>Wire entry view</p>	1	Jump to 2	<p><b>CONNECTOR</b> Molex/42816-0512</p> <p><b>CONTACTS</b> Molex/428150114 (10-12 AWG)</p> <p><b>CRIMP TOOL</b> Molex/63811-1600</p> <p><b>PIN EXTRACTOR</b> Molex/63813-0400</p>
	2	Jump to 1	
	3	AC Phase	
	4	AC Phase	
	5	AC Phase	

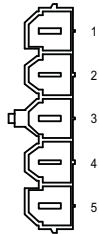
P1 - Single Phase AC Input	Pin#	Signal	Mate
 <p>Wire entry view</p>	1	Jump to 2	<p><b>CONNECTOR</b> Molex/42816-0512</p> <p><b>CONTACTS</b> Molex/428150114 (10-12 AWG)</p> <p><b>CRIMP TOOL</b> Molex/63811-1600</p> <p><b>PIN EXTRACTOR</b> Molex/63813-0400</p>
	2	Jump to 1	
	3	AC Phase	
	4	AC Phase	
	5	No Connect	

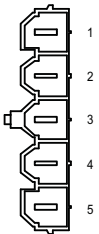
P1 - 5-Wire AC Input	Pin#	Signal	Mate
 <p>Wire entry view</p>	1	Neutral	<p><b>CONNECTOR</b> Molex/42816-0512</p> <p><b>CONTACTS</b> Molex/428150114 (10-12 AWG)</p> <p><b>CRIMP TOOL</b> Molex/63811-1600</p> <p><b>PIN EXTRACTOR</b> Molex/63813-0400</p>
	2	No Connect	
	3	AC Phase	
	4	AC Phase	
	5	AC Phase	

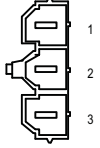
P5 - DC Output	Pin#	Signal	Mate
 <p>Wire entry view</p>	1	V+	<b>CONNECTOR</b> Molex/42816-0312  <b>CONTACTS</b> Molex/428150114 (10-12 AWG)  <b>CRIMP TOOL</b> Molex/63811-1600  <b>PIN EXTRACTOR</b> Molex/63813-0400
	2	V-	
	3	Chassis	

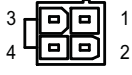
P2 - Contactor Control	Pin#	Signal	Mate
 <p>Wire entry view</p>	1	Coil + (no polarity for AC)	<b>CONNECTOR</b> Molex/39-01-2040  <b>CONTACTS</b> Molex/39-00-0038  <b>CRIMP TOOL</b> Molex/63811-5000  <b>PIN EXTRACTOR</b> Molex/11-03-0044
	2	Coil- (no polarity for AC)	
	3	No connect	
	4	No connect	

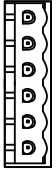
P3 - Pilot Power and Control	Pin#	Signal	Mate
 <p>Wire entry view</p>	1	No connect	<b>CONNECTOR</b> Phoenix/1757051  <b>CONTACTS</b> N/A (screw terminals)  <b>CRIMP TOOL</b> N/A  <b>PIN EXTRACTOR</b> N/A
	2	No Connect	
	3	Drive Power Request -	
	4	Drive Power Request +	
	5	Pilot Power - (no polarity for AC)	
	6	Pilot Power + (no polarity for AC)	

# APPENDIX C: LED STATUS CODES

Note: The information in this table applies to firmware version 1.5.1 and greater.

LED on solid ● LED off ○

Operational Status		Red	Yellow	Green	Description
Operation Modes	<b>No Operation</b>	○	○	○	No Pilot Power (all LEDs off)
	<b>Normal Operation</b>	○	○	●	Pilot Power on, DC bus off, IPC ready for Drive Power Request
		○	○	toggle	IPC powering up - soft start phase
		○	○	flicker	IPC operational - DC bus fully powered
		○	○	toggle	IPC DC bus shutting down, dumping DC bus power
	<b>Operational Warning</b>	○	blink (2)	flicker	Thermal warning - temperature > = 60°C
IPC is functional but a condition exists that requires attention					
Shutdown Modes	<b>Soft Fault</b> Toggle DPR to clear	○	blink (2)	●	Drive Power Request asserted before Pilot Power was on
		○	blink (3)	●	Bus supply failed to reach min voltage threshold on power up
		○	blink (4)	●	Over temperature fault
		○	blink (5)	●	DPR off-request followed by DPR on-request before IPC fully shut down
		○	blink (6)	●	AC phases disconnected
		○	blink (8)	●	Current calibration error
		○	blink (10)	●	DC output drops below user-configurable setting (for 1 mS min)
	<b>Safety Hazard</b> A dangerous condition exists	●	blink (2)	○	Contactor failed to open - possibly welded
		●	blink (3)	○	AC input voltage high (or 3-pulse wired for 6-pulse)
	<b>User Equipment Fault</b> Cycle Pilot Power to clear	○	blink (2)	○	Over voltage after regen
		○	blink (3)	○	Output current overload
		○	blink (4)	○	Short or reverse polarity at output
		○	blink (5)	○	Contactor failed to close
		○	blink (6)	○	RMS current limit exceeded
	<b>IPC Hardware Fault</b> Hard failure - return to Teknic	●	●	●	Processor failure (all LEDs on solid)
		All blink (2)			Internal logic supply problem
All blink (3)			Fan failure		
All blink (other)			Call Teknic		

LED Code Blink Timing

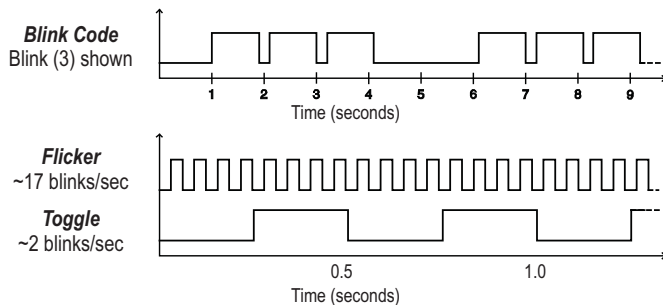

**Teknic Incorporated**

7650 Omnitech Pl

Victor, NY 14564

Copyright © 2026 Teknic Inc. All rights reserved.