

### Overview:

ClearCore is an industrial quality, I/O and Motion Mini-Controller with numerous wired/wireless connectivity options. When compared to PLCs, custom control boards, and embedded PCs, ClearCore's hardware and software features reduce the engineering and manufacturing costs of machine controls.

### Features:

- Robust electrical hardware with numerous protection features minimize problems during commissioning and in the field.
- All I/O points are compatible with 24V industrial sensors and actuators as well as 3.3-5.0V logic.
- Individual plug terminal blocks for each I/O point include signal and power pins to minimize the need for external wiring devices and harnessing effort.
- All configuration of the I/O and communication port hardware is controlled by software, i.e., no jumpers, DIP switches, trim-pots, etc. need to be manually set.
- C++ HAL interface libraries speed embedded development.
- Rapid machine prototyping is supported by the optional Arduino wrapper libraries.
- The 13 built-in I/O points are configurable as any combination of up to 13 digital inputs, 4 analog inputs, 6 digital outputs, 2 speaker outputs and 1 analog output (0-20mA or 4-20mA).
- Four (4) motor control ports directly control ClearPath<sup>®</sup> all-in-one servo motors for simplified motion control integration. These ports are also compatible with popular step motor drives.
- I/O can be expanded up to 77 points total using optional CCI0-8, 8-point expansion modules.
- Outputs can directly drive resistive or inductive loads up to 9W.
- Two multi-functional serial ports, individually configurable for use with SPI or UART devices; (each port includes 5V power pins for the remote device, where necessary).
- Included 10Base-T/100Base-TX Ethernet port.
- Accepts Xbee modules for wireless connectivity (Mesh, Wi-fi, Bluetooth, etc.). Think IoT.
- Powered by a single 24VDC supply.
- SD card support for data logging, machine configuration data, and disk emulation.
- 32-bit floating point ARM M4F processor @120MHz with 512KB FLASH and 192KB RAM

**Input Equivalent Circuit**

**Typical Sensor Hookup Details**

IO-0 through IO-5 configured as digital inputs

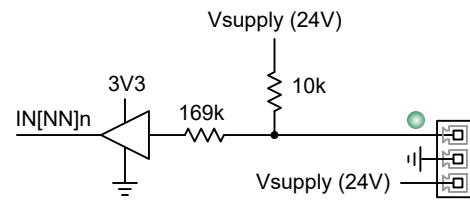

**IMPORTANT:**  
Inputs are "negative true".  
On <= ~0.75V, Off >= ~2.75V

**NPN DEVICES ARE STRONGLY RECOMMENDED OVER PNP DEVICES FOR EASE OF WIRING.**

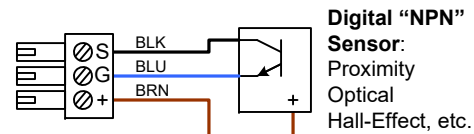

**Digital "NPN" Sensor:**  
Proximity  
Optical  
Hall-Effect, etc.

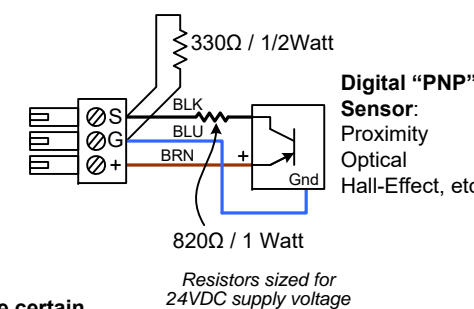
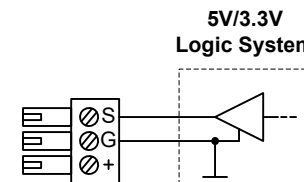
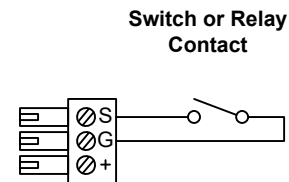

**Digital "PNP" Sensor:**  
Proximity  
Optical  
Hall-Effect, etc.

Resistors sized for 24VDC supply voltage

Sensor wire colors, where shown, are typical, check sensor data sheets to be certain.

**Recommended wire gauge range:**  
20AWG - 24AWG (0.8mm -0.5mm)  
**Mating Plug Terminal Block:**  
Molex/0395105003 (3.81mm pitch)  
**Recommended Ferrule:**  
American Electrical/1181050 (20-24AWG)  
**Recommended Ferrule Crimp Tool:**  
American Electrical/TRAP 22-10

A-9 through A-12 configured as digital inputs;  
DI-6 through DI-8 digital inputs

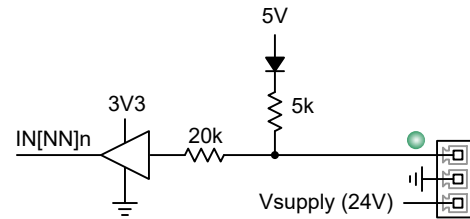

**IMPORTANT:**  
Inputs are "negative true".  
On <= ~0.75V, Off >= ~2.75V

**NPN DEVICES ARE STRONGLY RECOMMENDED OVER PNP DEVICES FOR EASE OF WIRING.**

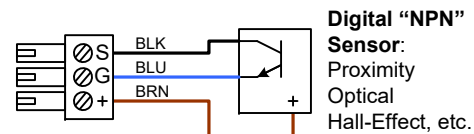

**Digital "NPN" Sensor:**  
Proximity  
Optical  
Hall-Effect, etc.

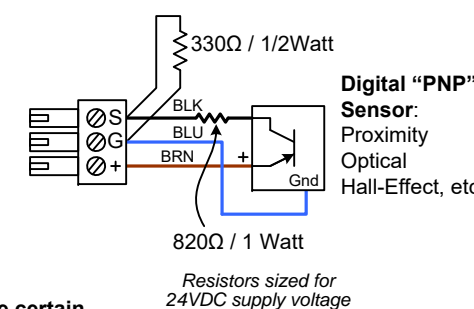
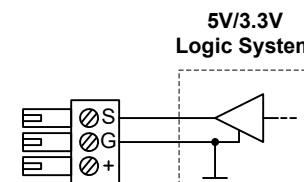
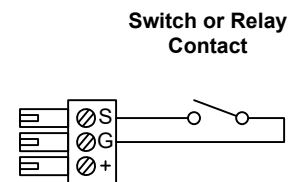

**Digital "PNP" Sensor:**  
Proximity  
Optical  
Hall-Effect, etc.

Resistors sized for 24VDC supply voltage

Sensor wire colors, where shown, are typical, check sensor data sheets to be certain.

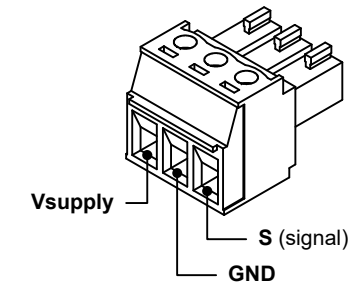

A-9 through A-12 configured as analog inputs  
(Cfg[NN]\_AIN\_DINn = Hi)

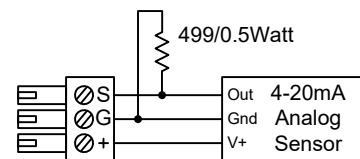
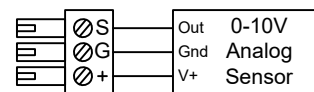
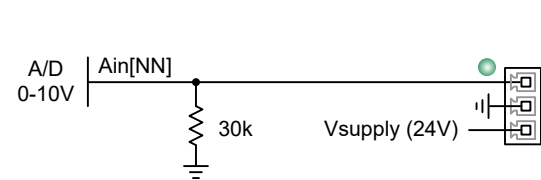

Note:  
Place the 499 Ohm shunt resistor close to input terminal block.

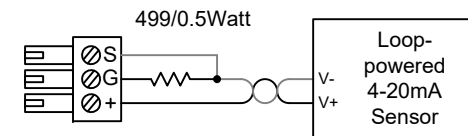

Notes:  
• Place the 499 Ohm shunt resistor close to input terminal block.  
• Use twisted pair wire as shown to minimize noise pickup.

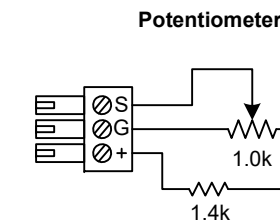

Note:  
The repeatability of this circuit will be affected by the drift and regulation of the power supply connected to Vsupply. (Values shown for a 24V supply.)

**Analog Sensor (Transducer)**

- Examples:**
- |           |                  |
|-----------|------------------|
| Pressure  | Force            |
| Torque    | Temperature      |
| Angle     | Inclination      |
| Distance  | Level            |
| Velocity  | Acceleration     |
| Mass Flow | Electric Current |

- Sensor Notes:**
- 0-5V output sensors can be used with loss of 1 bit of resolution (provided they are compatible with Vsupply)
  - 0-20mA sensors can be used with some loss of linearity near zero current (sensor dependent)

**Output Equivalent Circuit**

**Typical Actuator Hookup Details**

**IO-0 through IO-5 configured as digital outputs**

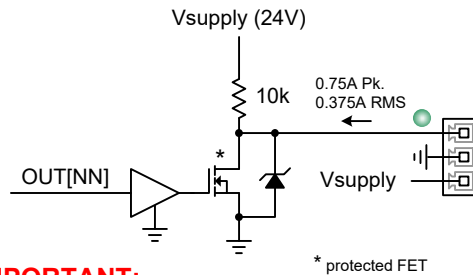

**IMPORTANT:**  
Outputs are "negative true":  
On state turns on transistor, enabling current in load, pulling output <0.5V

Relay  
Vacuum Valve  
Contactor Solenoid Guard Lock  
Pneumatic Valve Solenoid Actuator  
Fluid Valve (e.g., diverter)

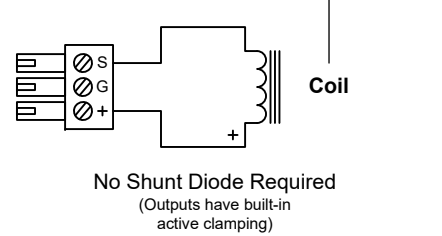

**DC Motor, Pump, etc. (single direction)**

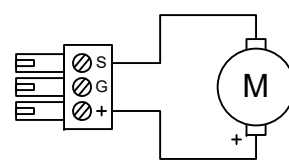

**DC Fan**

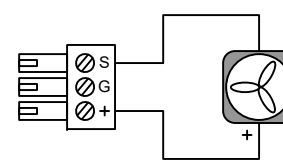

**LED Indicator**

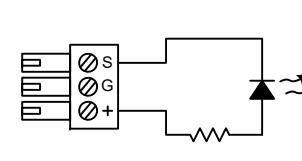

**Solid State Relay**

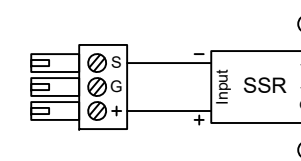

**5V/3.3V Logic System**

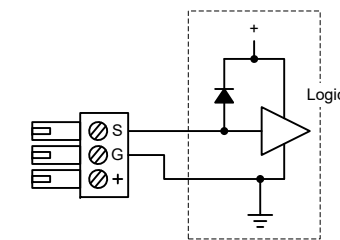

External clamping diode to logic supply may be required, consult logic IC datasheet.

**IO-4 or IO-5 configured as variable bi-directional drive (PWM)**

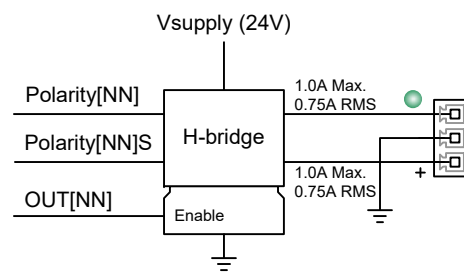

Average output voltage =  $V_{supply} * (\text{Duty Cycle of PolarityS} - \text{Duty Cycle of Polarity})$

**Loudspeaker/Shaker**

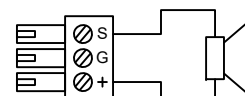

**DC Motor, Pump, etc. (fwd/rev direction)**

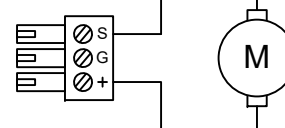

**Galvanometer**

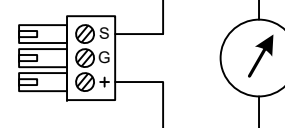

**Notes:**

- for use with loudspeaker/shaker loads the maximum RMS current must not exceed 1A
- Exceeding output current ratings will require resetting both IO-4 and IO-5 outputs by cycling the OverV\_DISABLEn signal

**Recommended wire gauge range:**  
20AWG - 24AWG (0.8mm -0.5mm)

**Mating Plug Terminal Block:**  
Molex/0395105003 (3.81mm pitch)

**Recommended Ferrule:**  
American Electrical/1181050 (20-24AWG)

**Recommended Ferrule Crimp Tool:**  
American Electrical/TRAP 22-10

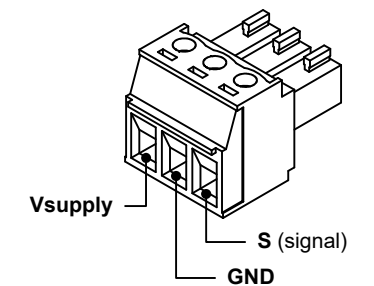

**IMPORTANT!**

The sum of the output currents for all outputs (IO-0 through IO-5) must not exceed 2.5A RMS

**IO-0 when configured as a 4-20mA analog output (0-20mA optional)**

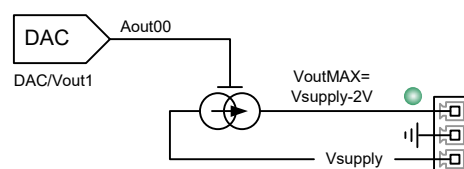

Output produces positive current flow through the S (signal) pin as shown, i.e., output is "sourcing"

**4-wire Actuator**

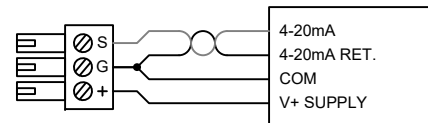

**3-wire Actuator**

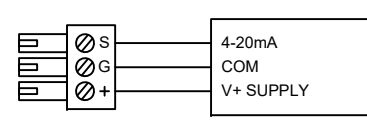

**3-wire 0-10V Actuator**

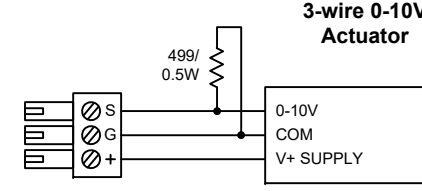

Note:  
Place 499 Ohm shunt resistor close to actuator

**2-wire Control**

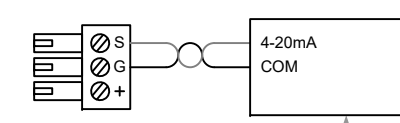

(MAY BE REQ. DEPENDING UPON DEVICE)

**Notes:**

- Connect signal and supply return wires close to output terminal block
- Use twisted pair as shown for best noise immunity

**Analog Actuator Examples:**

- Damper control
- Proportional valve
- Pressure regulator
- Linear position actuator
- Rotary position actuator
- Process meter (display)
- Variable speed drive

**COM Port Equivalent Circuits**

**Typical Hookup Details**

**COM-[N] For use with 5V compatible RS-232 transceivers**

(CfgCom[N]\_UART\_SPIIn = Low, CfgCom[N]\_Polarity = Hi)

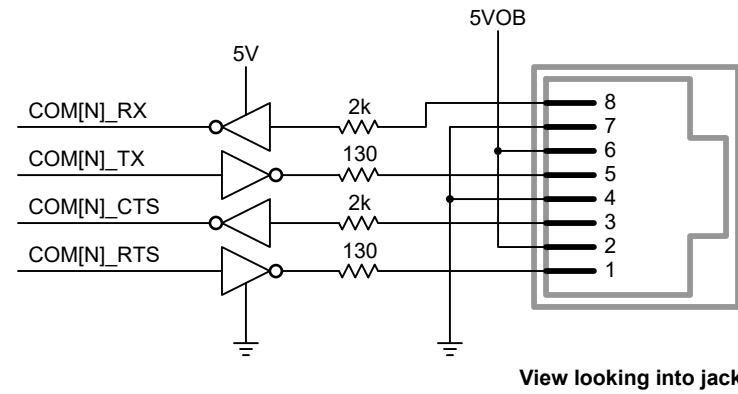

**DCE/Modem**

(Male Connector Shown e.g., Amphenol/DE09P064TXLF)

**DTE/Host**

(Female Connector Shown e.g., Amphenol/DE09S064TLF)

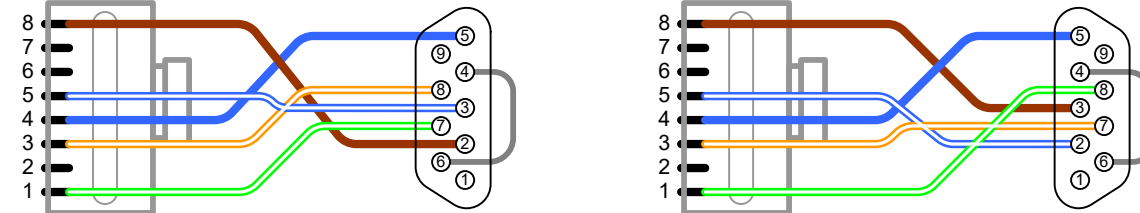

Wire entry view (i.e., opposite of mating side) shown for all connectors; TIA T568A wire colors shown

**IMPORTANT:** Mating serial port must be compatible with 0-5V signals (or a converter must be used)

**COM-[N] For use with 5V logic UART devices**

(non-inverting) (CfgCom[N]\_UART\_SPIIn = Low, CfgCom[N]\_Polarity = Low)

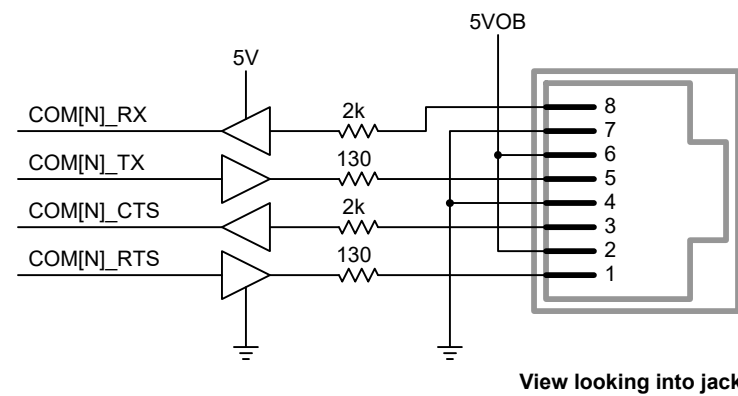

5VOB Supplies 5V power for any loads connected to the COM-0 and COM-1 connectors. 5VOB also supplies the Xbee module when installed. The total current available from 5VOB is 450mA. (See block diagram on page 7.)

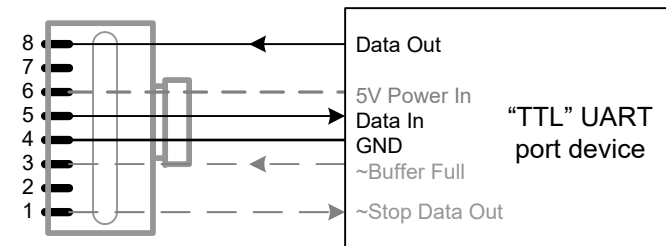

**COM-[N] For use with SPI devices**

(CfgCom[N]\_UART\_SPIIn = Hi, CfgCom[N]\_Polarity = Low)

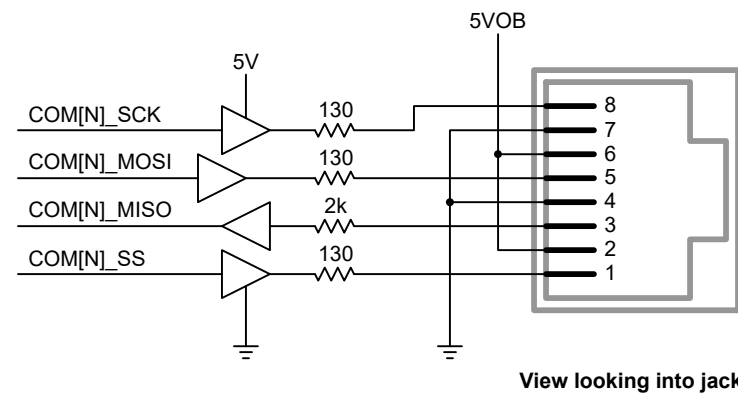

5VOB Supplies 5V power for any loads connected to the COM-0 and COM-1 connectors. 5VOB also supplies the Xbee module when installed. The total current available from 5VOB is 450mA. (See block diagram on page 7.)

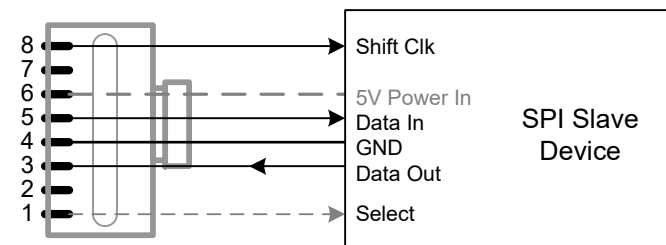

**Common Cat-5 Patch Cable Wire Colors**

**T568A Wire Colors**

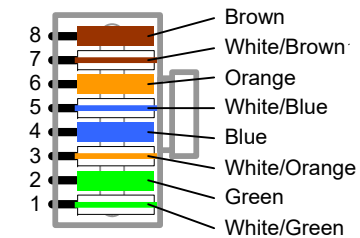

**T568B Wire Colors**

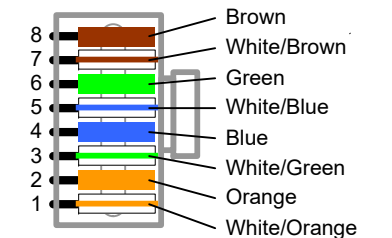

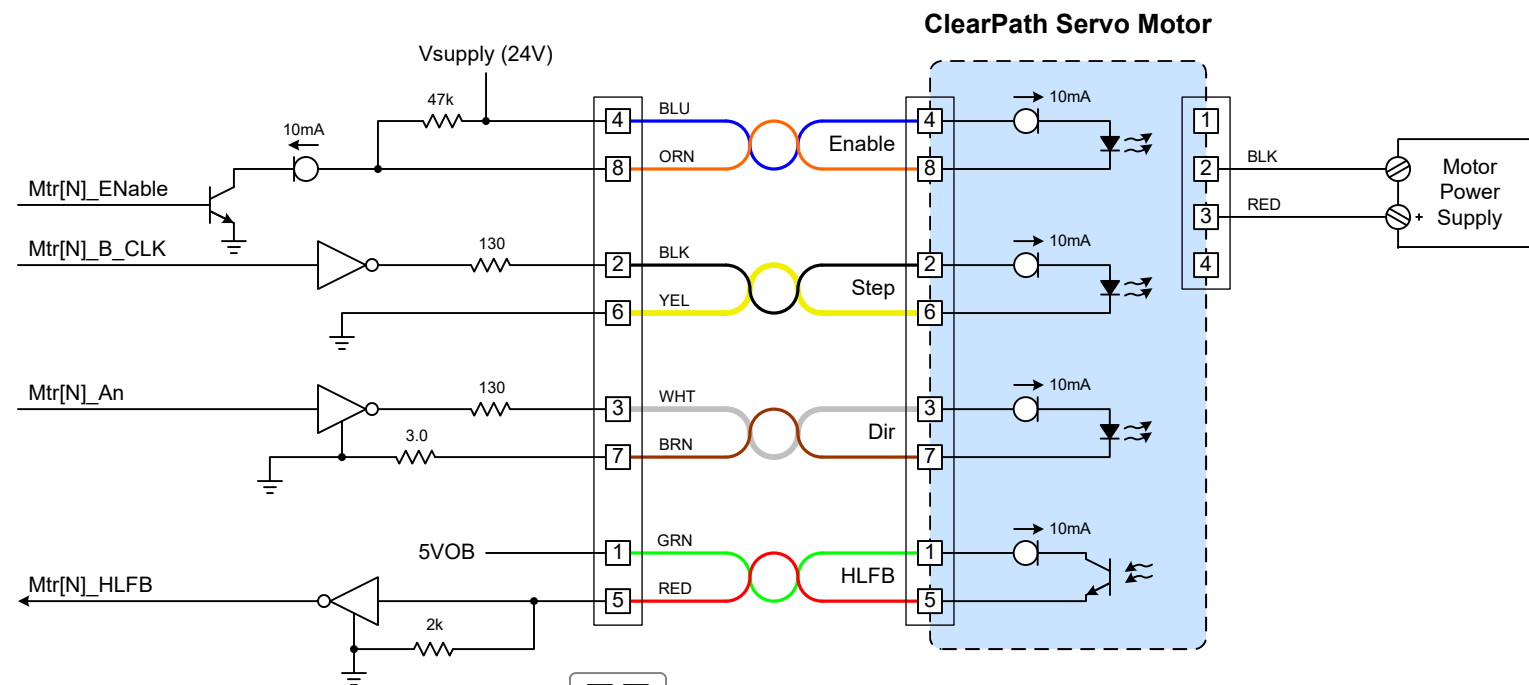

**Pre-fabricated motor control cables available from Teknic.com:**  
 10-foot (3.1m): CPM-CABLE-CTRL-MU120  
 55-foot (16.8m): CPM-CABLE-CTRL-MM660

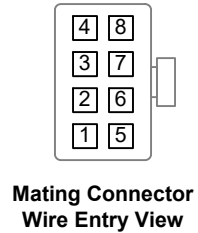

- Motor control cable components**
- Housing:** Molex/39-03-9082 (black)
  - Terminals:** Molex/39-00-0047 (loose); Molex/ 39-00-0046 (reel)
  - Crimp Tool:** Molex/63819-0900
  - Extractor Tool:** Molex/11-03-0044

**Typical Stepper Motor Drive**

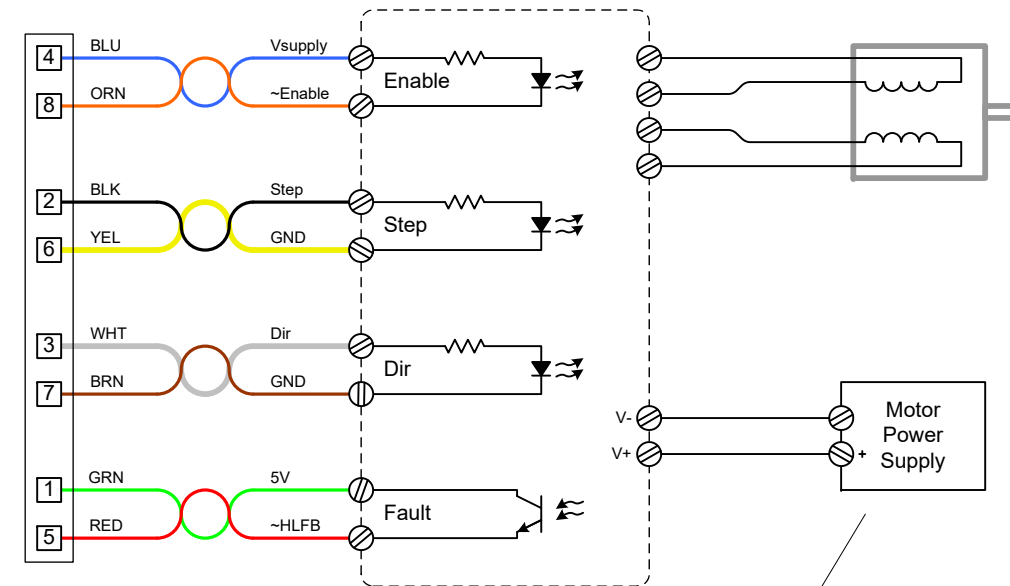

**IMPORTANT!**

Do not power the ClearCore from the motor power supply. Regenerated power from the motor drives will raise the supply voltage causing ClearCore shutdown events.

Removing the cover

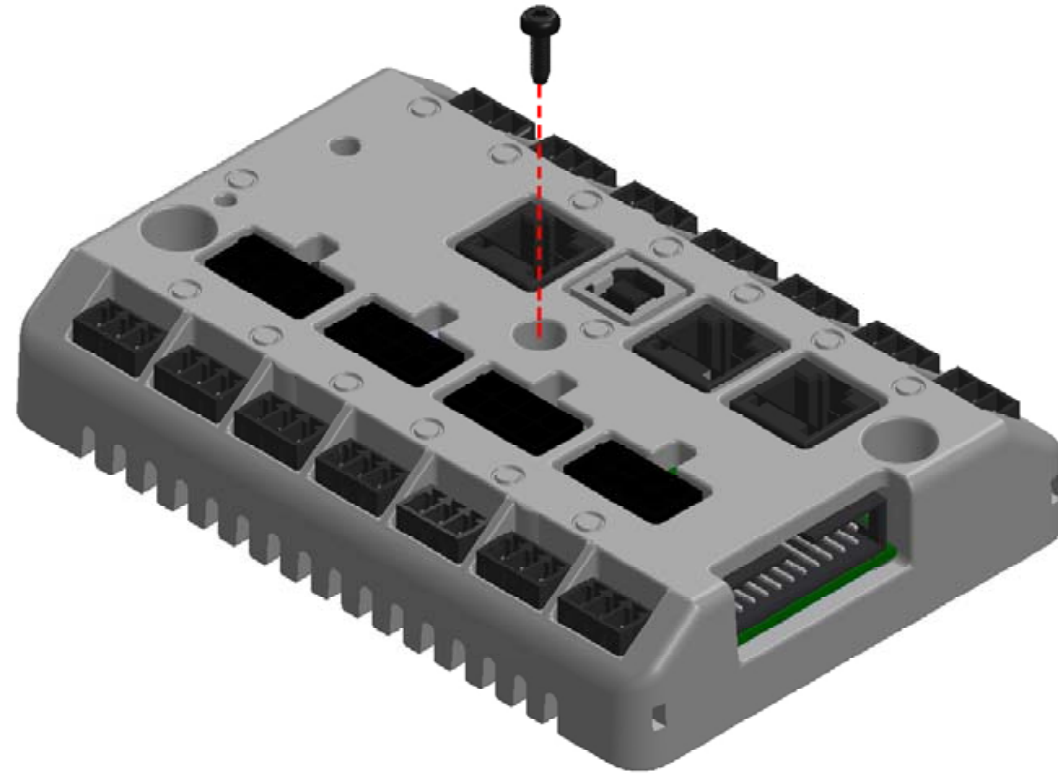

Connecting a debugger using a TAG-Connect cable

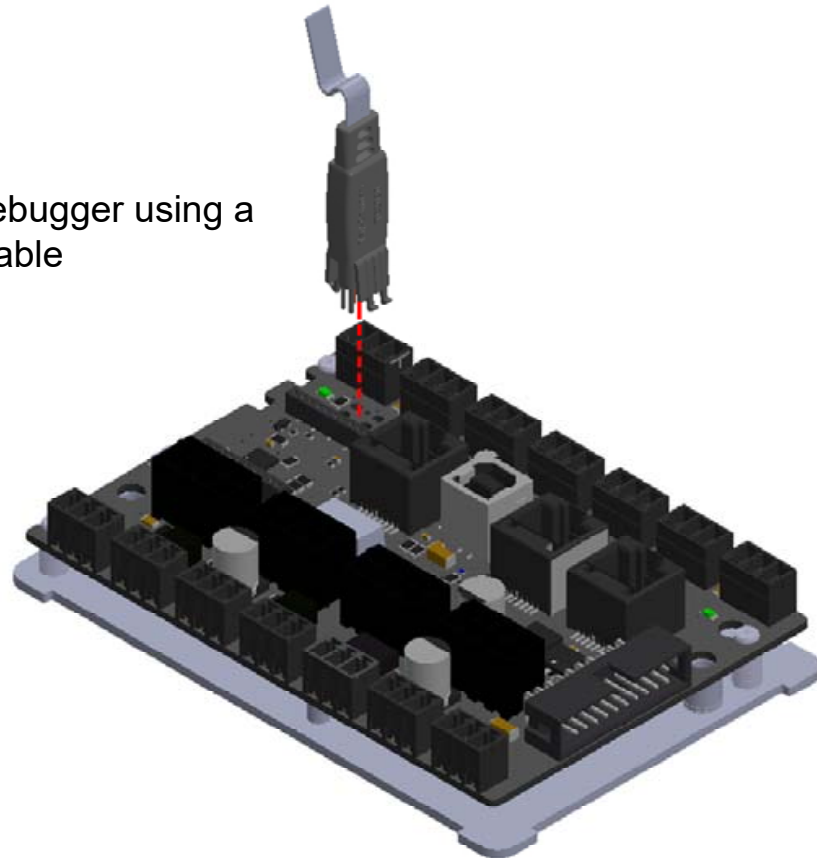

Installing an Xbee Module

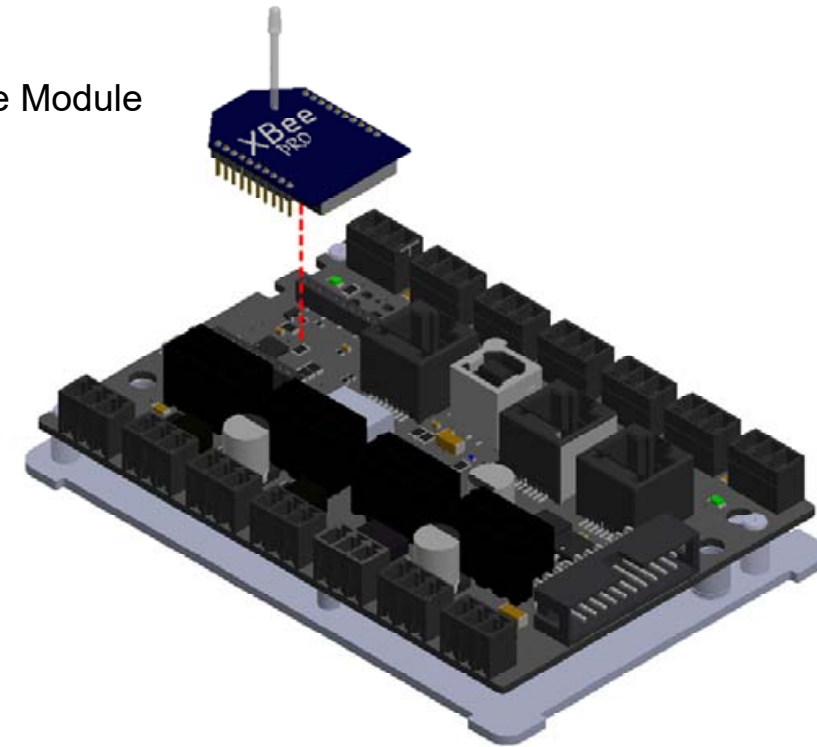

# Processor Signal Routing Block Diagram: I/O and Communication

## Signal Name Conventions

- Curly braces “{ }” enclose an alternate signal name appropriate when the hardware is configured for the alternate use
- Any signal name ending in lower case “n” indicates that it is true in a low state (i.e., “negative true”)

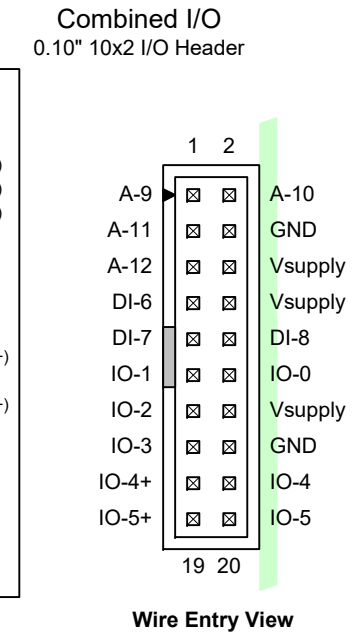
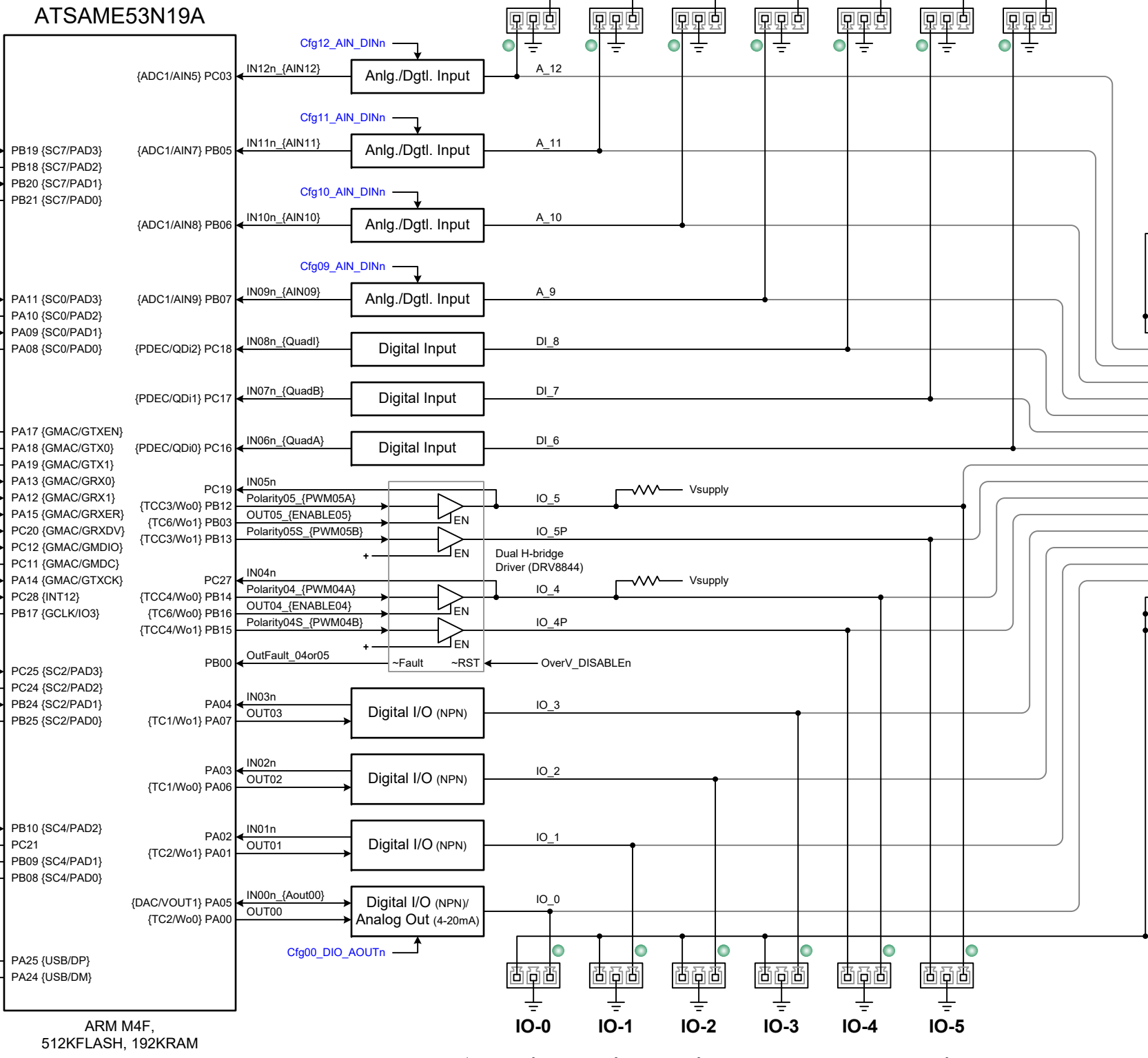
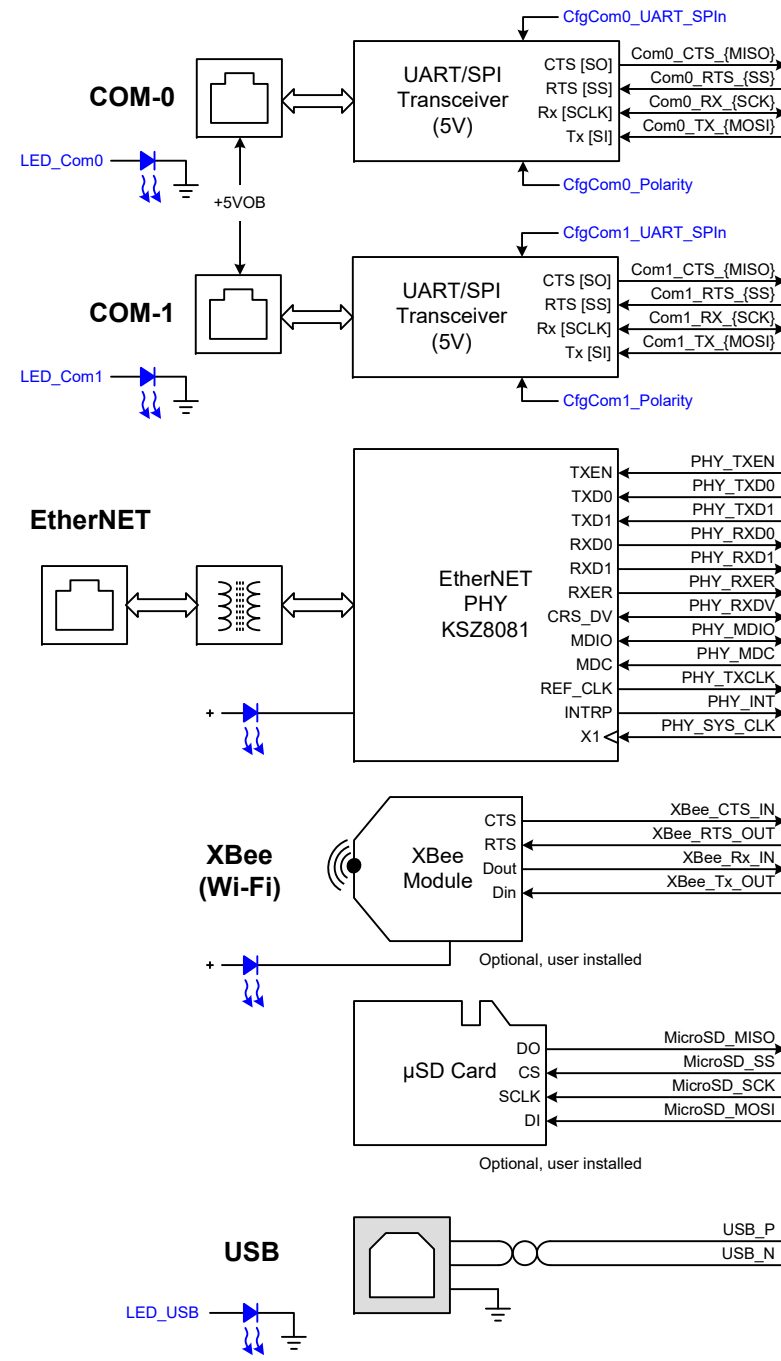

**Mating Ribbon Cable Connector**  
 OST/101-206

**Mating Crimp Connector**  
 Housing: AMP/102387-4  
 Terminals: AMP/87756-4 (22-26AWG)

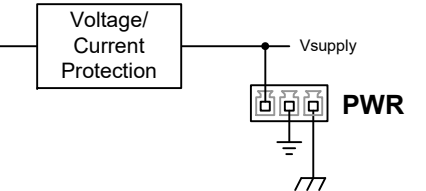

**IMPORTANT:**  
 Only apply power through the PWR terminal block or protection will be circumvented.

Processor Signal Routing Block Diagram: Motor I/O; Configuration Shift Register

