



# ClearLink Hardware Manual

Includes wiring information for CCIO-8 (I/O Expansion Board)

Rev. 1.09 / December 17, 2025



## Table of Contents

<b>Table of Contents</b> .....	<b>2</b>
<b>Introduction</b> .....	<b>4</b>
Welcome .....	4
What's in this Document .....	4
<b>Safety Information</b> .....	<b>5</b>
Precautionary Statement .....	5
General Disclaimer .....	5
<b>Example ClearLink System</b> .....	<b>6</b>
<b>Parts Overview</b> .....	<b>7</b>
Parts of a ClearLink .....	7
Parts of a CCIO-8 (I/O Expansion Board).....	8
<b>Powering ClearLink and CCIO-8</b> .....	<b>9</b>
Recommended Power Supply .....	9
PWR-IO-24VDC.....	9
Wiring DC Power to ClearLink and CCIO-8.....	10
<b>Wiring I/O to ClearLink</b> .....	<b>11</b>
Introduction .....	11
I/O Overview Table .....	11
Wiring I/O to the Outer I/O connectors .....	12
I/O-0 through I/O-5 configured as DIGITAL INPUTS .....	13
A-9 through A-12 and DI-6 through DI-8 configured as DIGITAL INPUTS.....	14
A-9 through A-12 configured as ANALOG INPUTS .....	15
I/O-0 through I/O-5 configured as DIGITAL OUTPUTS .....	16
I/O-0 configured as a 4-20mA (or 0-20mA) OUTPUT .....	17
ClearLink Combined I/O Header .....	18
Wiring I/O Devices to CCIO-8.....	19
I/O-0 through I/O-7 configured as DIGITAL INPUTS .....	19
I/O-0 through I/O-7 configured as DIGITAL OUTPUTS .....	19
CCIO-8 Combined I/O Header.....	19
<b>Motor Connectors (M-0, M-1, M-2, M-3)</b> .....	<b>20</b>
How to Wire a ClearPath Motor to ClearLink.....	21
ClearPath Controller Cables .....	21

Wiring a Stepper Motor Drive to ClearLink .....	22
<b>COM-0 (Serial COM Port) .....</b>	<b>23</b>
COM-0 with 5V compatible RS-232 transceivers .....	24
COM-0 configured for 5V logic UART devices .....	25
<b>CL-ENCDR-DFIN Encoder Input Adapter Board .....</b>	<b>26</b>
Introduction .....	26
Connectors and Pinouts.....	27
Dimensions .....	28
Specifications.....	28
<b>Appendix A: Specifications .....</b>	<b>29</b>
ClearLink Specifications.....	29
ClearLink I/O Function Table .....	30
CCIO-8 Specifications.....	31
CCIO-8 I/O Function Table .....	32
<b>Appendix B: Mechanical Reference .....</b>	<b>33</b>
ClearLink Mounting and Clearance Dimensions .....	33
CCIO-8 Mounting and Clearance Dimensions.....	34
<b>Appendix C: Mating Connectors and Terminals.....</b>	<b>35</b>

## Introduction

---

### Welcome

Thank you for purchasing a **ClearLink EtherNet/IP Motion and I/O Controller**. This document is a hardware reference manual for the ClearLink controller, optional I/O expansion board ([CCIO-8](#)), and optional encoder input board ([CL-ENCDR-DFIN](#)).

For programming information, please see the [ClearLink EtherNet/IP Object Reference](#).

### What's in this Document

- Parts of a ClearLink (callout diagram)
- Wiring diagrams for common I/O and motor devices
- Power supply requirements
- Mating hardware information
- Product specifications
- Mechanical dimensions
- Mounting information

## Safety Information

### Precautionary Statement

Always follow appropriate safety precautions when installing and using any automated motion control equipment. Motion control systems should be designed and utilized to prevent personnel from coming into contact with moving parts and electrical contacts that could potentially cause injury or death. Read all cautions, warnings, and notes before attempting to install or operate this device. Follow all applicable codes and standards when using this equipment. Failure to use this equipment as described may impair or neutralize protections built into the product.

### General Disclaimer

The User is responsible for determining the suitability of this product for his or her application. The User must ensure that Teknic's products are installed and utilized in accordance with all local, state, federal and private governing bodies and meet all applicable health and safety standards.

Teknic has made all reasonable efforts to accurately present the information in the published documentation and shall not be responsible for any incorrect information which may result from unintentional oversights.

Due to continuous product improvements, the product specifications as stated in the documentation are subject to change at any time and without notice. The User is responsible for consulting a representative of Teknic for detailed information and to determine any changes of information in the published documentation.

Should Teknic's products be used in an application that is safety critical, the User must provide appropriate safety testing of the products, adequate safety devices, guarding, warning notices and machine-specific training to protect the operator and/or bystanders from injury.

# Example ClearLink System

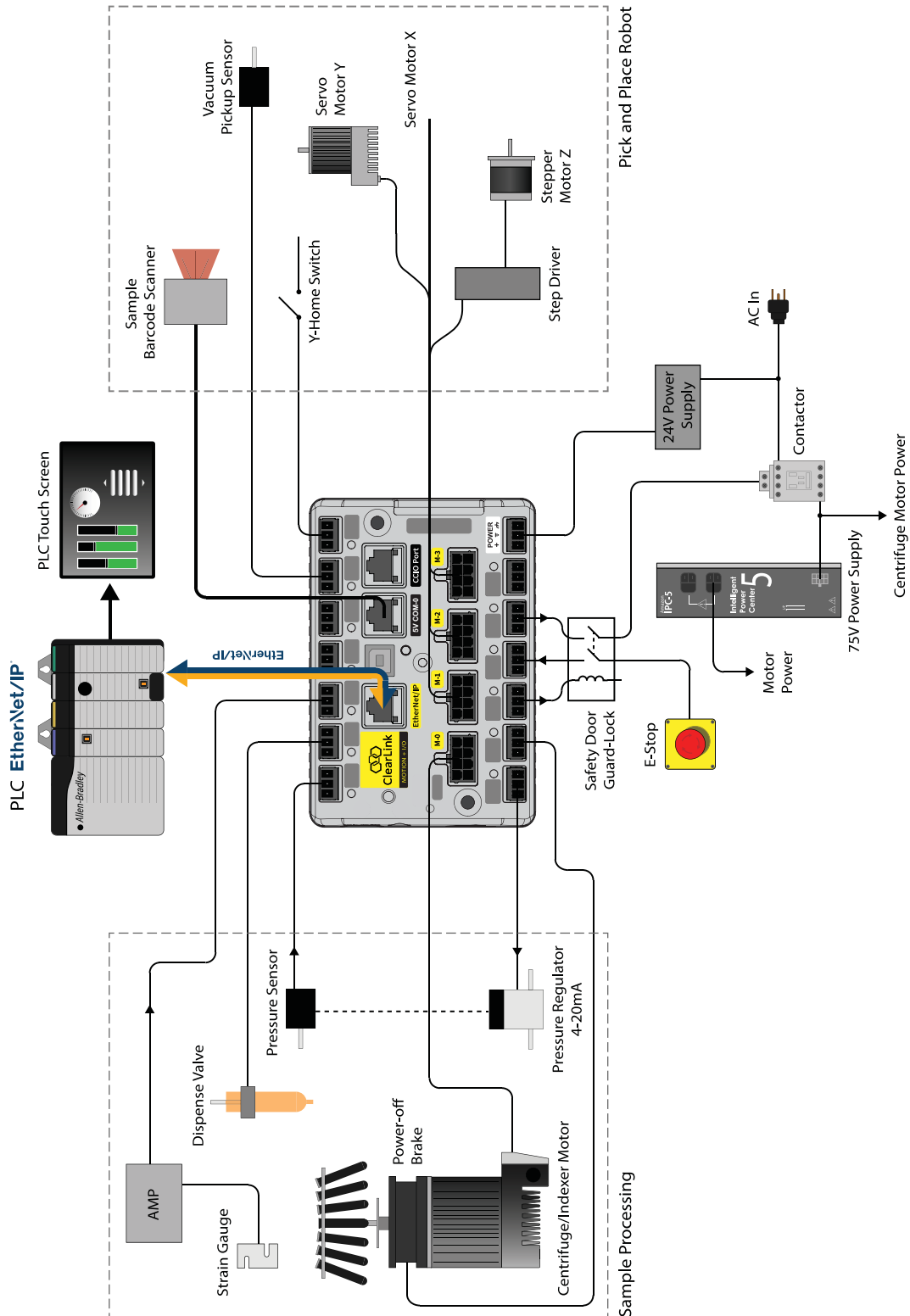

# Parts Overview

## Parts of a ClearLink

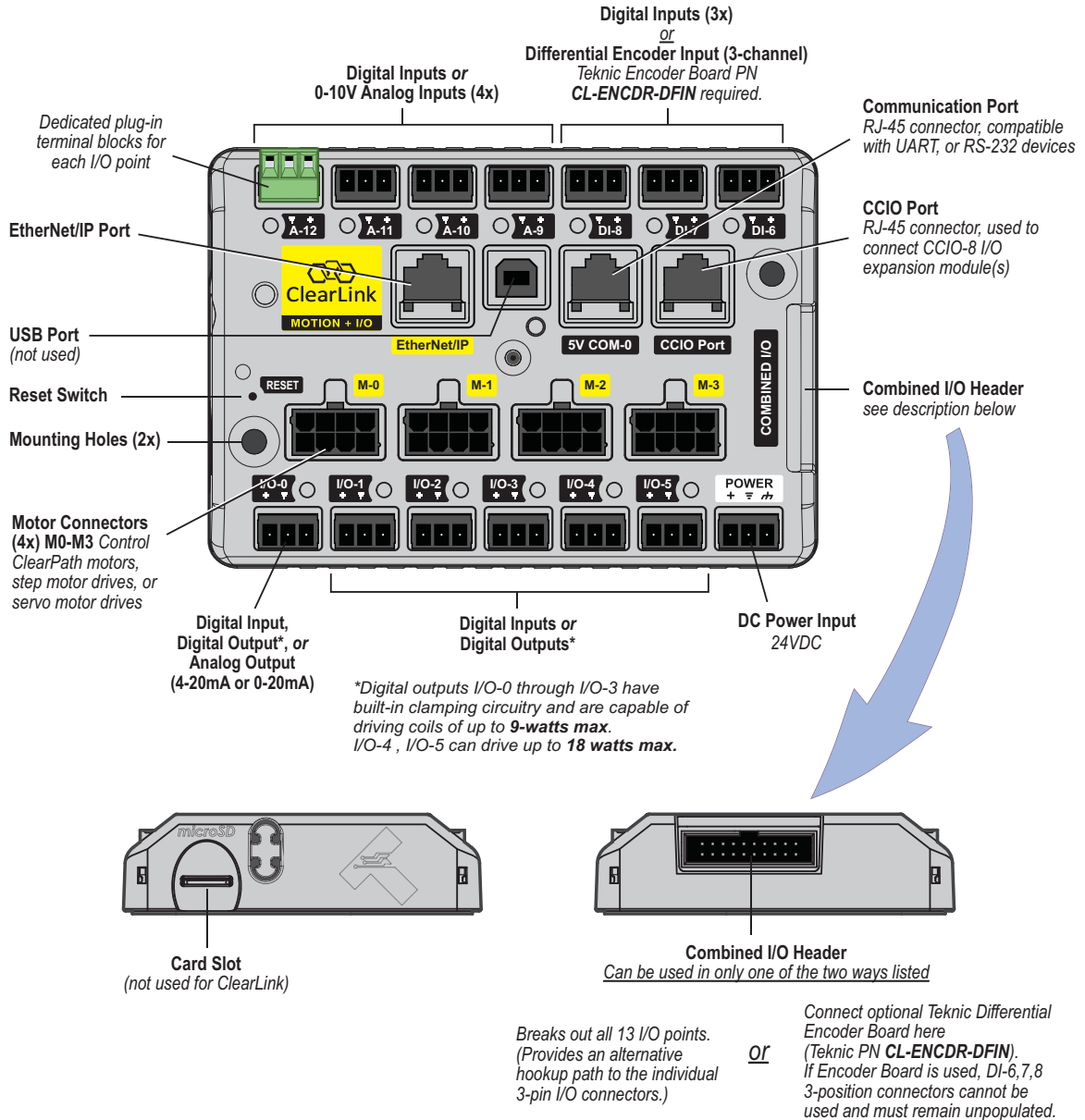

ClearLink top and side views

## Parts of a CCIO-8 (I/O Expansion Board)

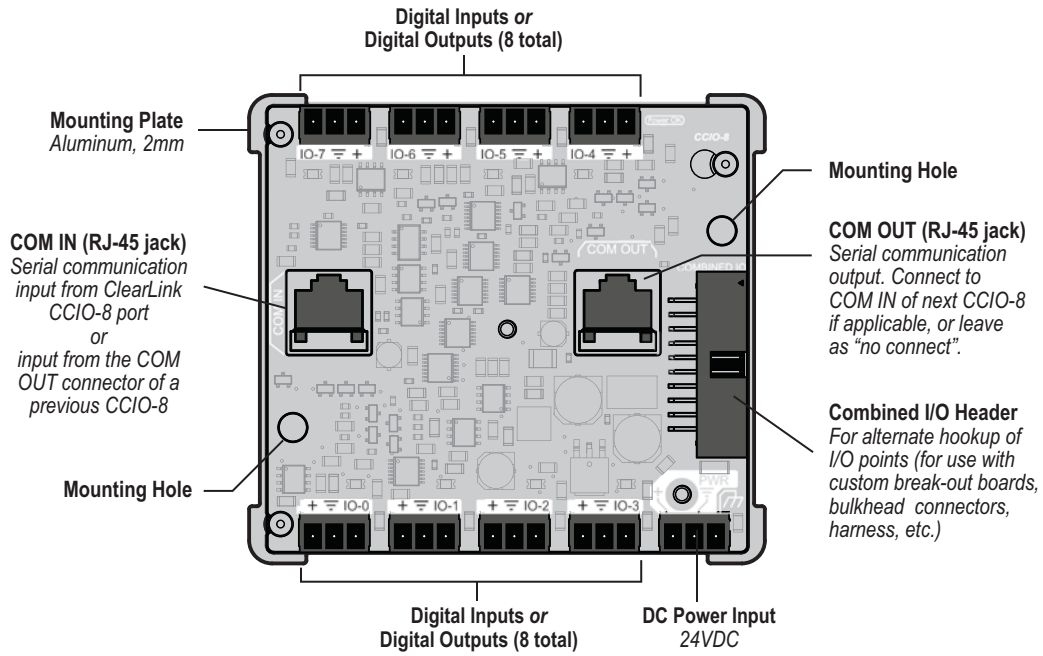

CCIO-8 I/O expansion board

## Powering ClearLink and CCIO-8

ClearLink and CCIO-8 are 24VDC compatible devices. This section includes ClearLink power supply recommendations and wiring instructions.

**Important:** Do not use your ClearLink power supply to also supply DC bus power to servo or stepper drives attached to ClearLink (this applies to ClearPath motors well). **Always use a separate, dedicated power supply, such as the [IPC-5](#), that is specifically designed to meet the power and regenerated energy requirements of servo or stepper motor drives.**

### Recommended Power Supply

#### PWR-IO-24VDC

The [PWR-IO-24VDC](#) power supply (Mean Well PN LRS-150-24) is an inexpensive, 24VDC, 6.5A (156W) switching supply capable of powering most ClearLink applications. Click [here](#) to view product datasheet.



#### Why choose a "higher current" power supply?

A power supply of 6.5A or more is recommended for ClearLink applications to ensure that the ClearLink processor always remains powered, even under adverse operating conditions such as overloads or shorts. Note: *Lower current supplies will work with ClearLink* but may experience shutdowns or brown outs if ClearLink is overloaded or shorted due to use or application error.

## Wiring DC Power to ClearLink and CCIO-8

See below for instructions on wiring 24VDC power to ClearLink and CCIO-8.

### Tools Required

- Slotted screwdriver with max. 2mm wide blade
- Wire cutter/stripper
- 3-position screw terminal connector, [Molex part # 0395105003](#)

### Procedure

1. Turn off power supply.
2. Strip DC output wires from power supply. Expose approximately **6.5mm (0.25")** of bare wire.
3. Fully insert V+ and V- wires fully into terminal block "+" and ground positions.
4. Tighten terminal screws.
5. Inspect connector for good wire capture. Verify that no wire insulation is captured in the closure, and that no loose wire strands are sticking out of the connector.
6. **Recommended:** Before connecting the terminal block to ClearLink, test for correct voltage polarity between "+" and ground terminals.

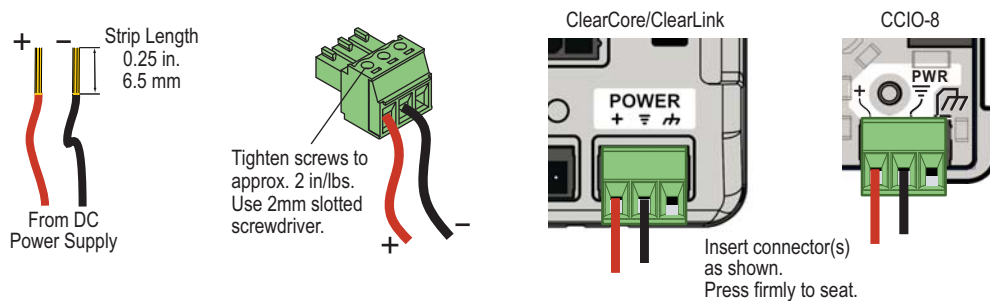

### Connecting power to ClearLink and CCIO-8

### Chassis Connection



Mount ClearLink and CCIO-8 to a machine frame or chassis continuous with Protective Earth. Alternately, connect the chassis terminal on the 3-position power connector to machine frame using conductive hardware.

## Wiring I/O to ClearLink

### Introduction

This section discusses the function and wiring of ClearLink and CCIO-8 user-configurable I/O points.

#### ClearLink I/O at a Glance

- (13) configurable I/O points
- Up to (13) digital inputs
- Up to (4) analog inputs
- Up to (6) digital outputs (with PWM)
- Up to (1) 4-20mA (or 0-20mA) output
- Separate ground and power for all I/O points (grounds not isolated)
- A dedicated status LED for every I/O point
- Add up to 64 more digital in/out points with Teknic's CCIO-8 (I/O expansion modules)

### I/O Overview Table

The table below lists all ClearLink and CCIO-8 I/O connectors and their supported I/O types. Refer to the ClearLink programming reference for instructions on how to configure ClearLink and CCIO-8 I/O connectors.

Label	Digital Input	Digital Output <sup>1</sup>	0-10V Analog Input	4-20 mA Output <sup>2</sup>	Servos or Steppers	Encoder Input
IO-0	yes	yes		yes		
IO-1	yes	yes				
IO-2	yes	yes				
IO-3	yes	yes				
IO-4	yes	yes				
IO-5	yes	yes				
DI-6	yes					yes <sup>5</sup>
DI-7	yes					yes <sup>5</sup>
DI-8	yes					yes <sup>5</sup>
A-9	yes		yes			
A-10	yes		yes			
A-11	yes		yes			
A-12	yes		yes			
M-0					yes <sup>3</sup>	
M-1					yes <sup>3</sup>	
M-2					yes <sup>3</sup>	
M-3					yes <sup>3</sup>	
CCIO-8 <sup>4</sup>	yes	yes				

Note 1: All digital outputs are PWM capable (except for those on the CCIO-8 expansion board).

Note 2: This output can also provide 0-20mA, which is less commonly used.

Note 3: Each motor connector has 3 digital outputs (step, dir., enable) and 1 digital input.

Note 4: There are 8 of these I/O points on the CCIO-8 expansion module.

Note 5: Additional encoder board required Teknic PN: CL-ENCNDR-DFIN

ClearLink I/O overview table

## Wiring I/O to the Outer I/O connectors

This section explains how to wire common I/O devices to a ClearLink controller. Each subsection includes a diagram of the ClearLink internal circuitry and several example hookup diagrams.

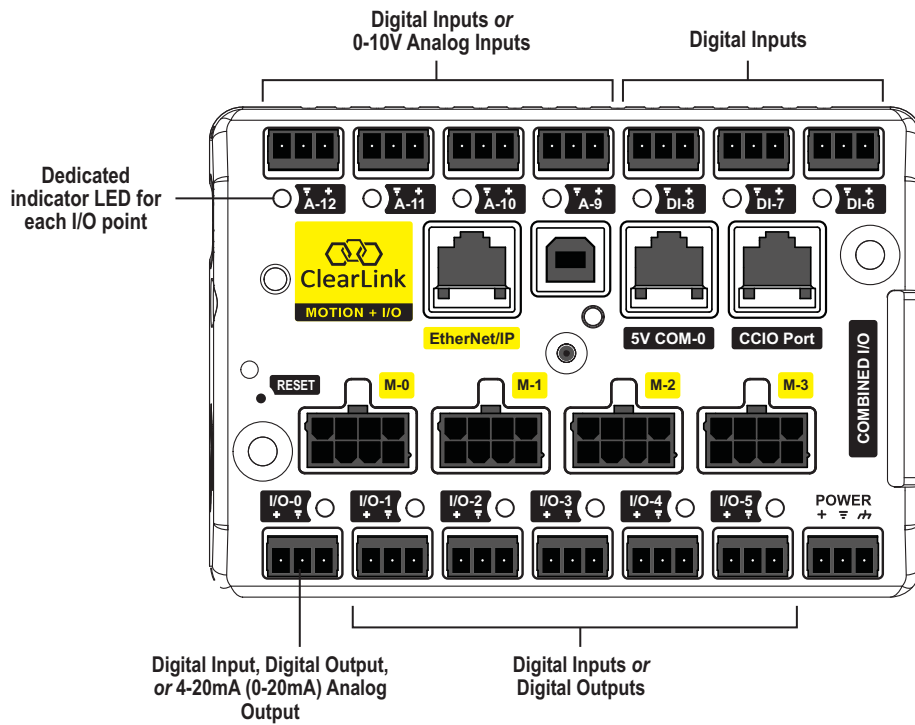

ClearLink I/O connectors

## I/O-0 through I/O-5 configured as DIGITAL INPUTS

**Note:** The wiring examples shown below **also apply to all CCIO-8 I/O points configured as digital inputs.**

### Input Equivalent Circuit

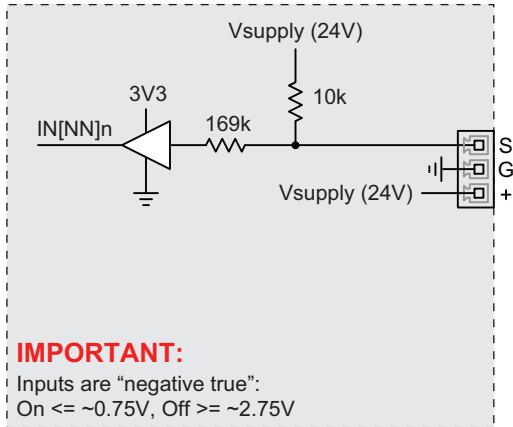

### "Ease of Use" Note: 5V Sensors

Before using 5VDC sensors, consider either 1) sourcing 24V alternatives, or 2) providing a separate 5VDC supply to power your 5V sensors.

### Typical Sensor Hookup Details

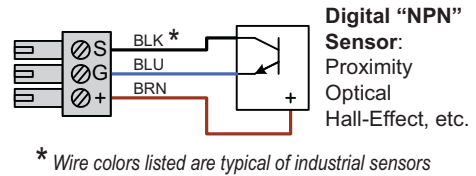

### Switch or Relay Contact

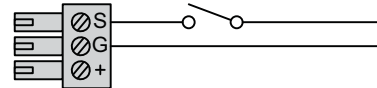

### 5V/3.3V Logic System

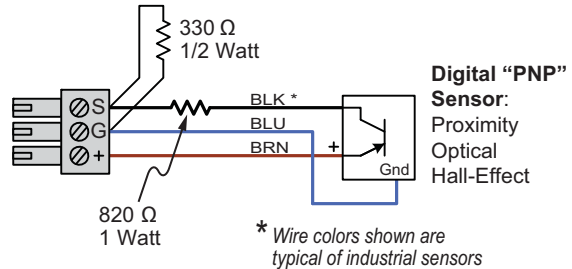
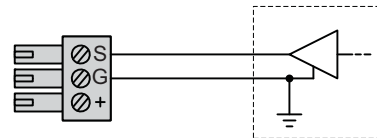

- Resistors sized for 24VDC supply voltage
- External resistors not included

## A-9 through A-12 and DI-6 through DI-8 configured as DIGITAL INPUTS

### Input Equivalent Circuit

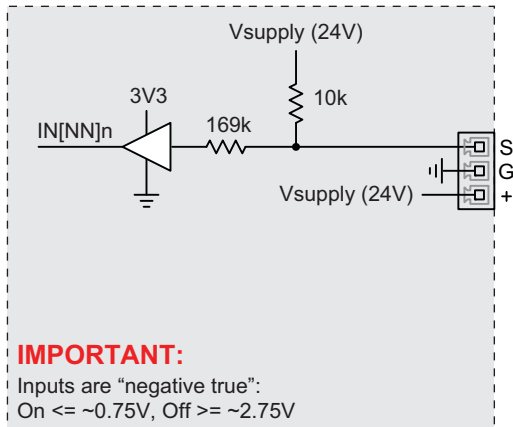

### "Ease of Use" Note: 5V Sensors

Before using 5VDC sensors, consider either 1) sourcing 24V alternatives, or 2) providing a separate 5VDC supply to power your 5V sensors.

### Typical Sensor Hookup Details

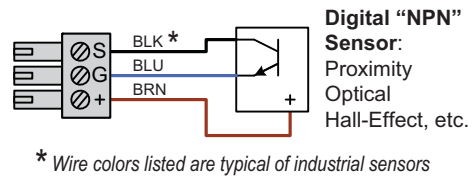

### Switch or Relay Contact

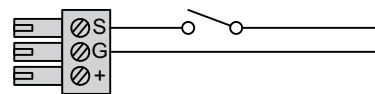

### 5V/3.3V Logic System

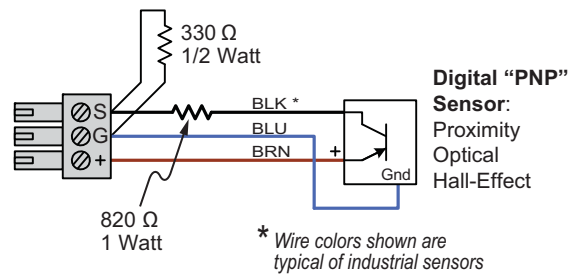
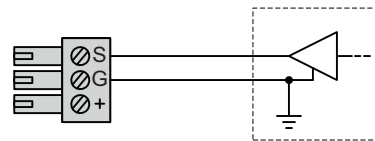

- Resistors sized for 24VDC supply voltage
- External resistors not included

### A-9 through A-12 configured as ANALOG INPUTS

ClearLink is compatible with a variety of analog sensors (transducers) including the following:

- Pressure
- Temperature
- Distance
- Mass
- Force
- Angle
- Level
- Flow
- Torque
- Inclination
- Velocity
- Electric current

#### Input Equivalent Circuit

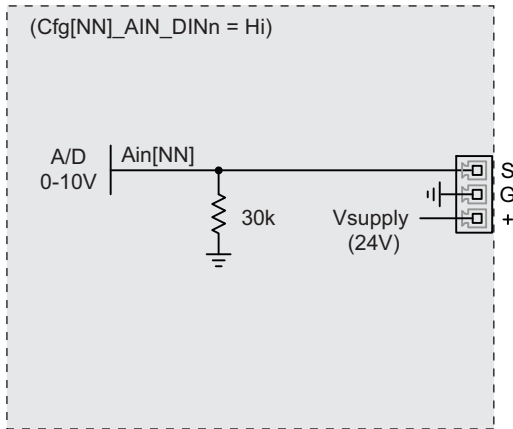

#### Typical Sensor Hookup Details

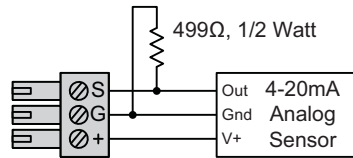
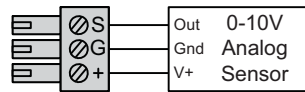

Note:  
Place the 499 Ohm shunt resistor close to input terminal block.

#### Typical Sensor Hookup Details

##### Potentiometer

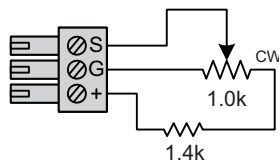

##### Engineering Note:

The repeatability of this circuit will be affected by the drift and regulation of the power supply connected to Vsupply. (Values shown for a 24V supply.)

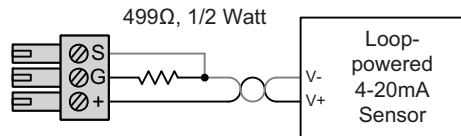

##### Notes:

- Place the 499 ohm shunt resistor close to input terminal block.
- Use twisted pair wire as shown to minimize noise pickup.

#### Sensor Notes:

- 0-5V output sensors can be used with ClearLink, but there will be a loss of 1 bit of resolution (provided they are compatible with the ClearLink supply voltage (Vsupply)).
- 0-20mA sensors can be used with ClearLink, but there will be some loss of linearity near zero current (this is sensor dependent).

## I/O-0 through I/O-5 configured as DIGITAL OUTPUTS

**Note:** The wiring shown in this section **also applies to all CCIO-8 points configured as digital outputs.**

### Output Equivalent Circuit

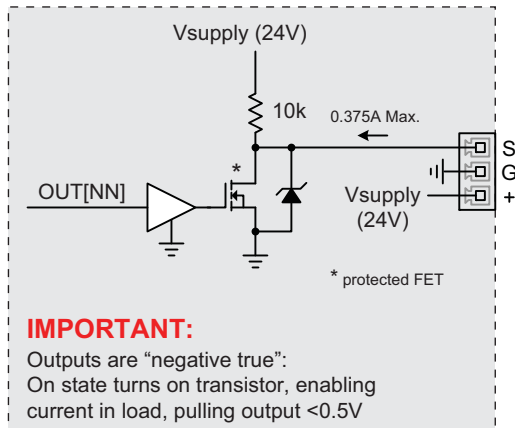

### Typical Actuator Hookup Details

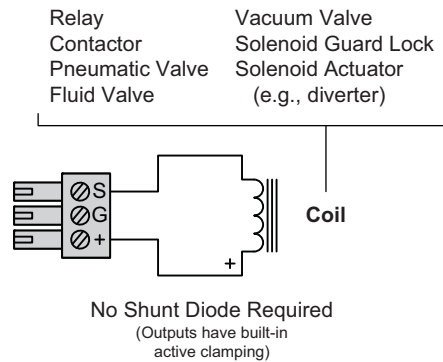

### Typical Actuator Hookup Details

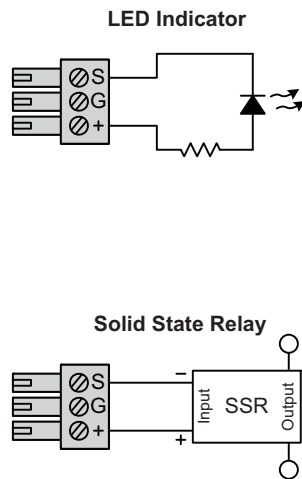

### DC Motor, Pump, etc. (single direction)

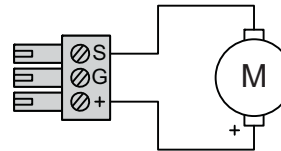

### DC Fan

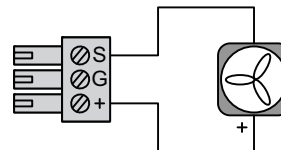

### 5V/3.3V Logic System

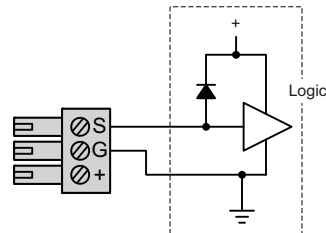

External clamping diode to logic supply may be required, consult logic IC datasheet.

## I/O-0 configured as a 4-20mA (or 0-20mA) OUTPUT

ClearLink connector I/O-0 can be configured to supply a variable 4-20mA analog signal to control a wide variety of analog actuators. A few examples of devices that can be controlled using 4-20mA signaling include:

- Damper control
- Pressure regulator
- Rotary position actuator
- Variable speed display
- Proportional valve
- Linear position actuator
- Process meter (display)

### Output Equivalent Circuit

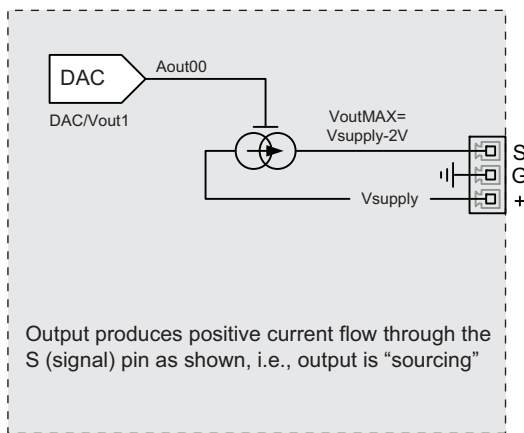

### Typical Actuator Hookup Details

#### 4-wire Actuator

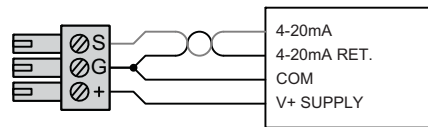

Notes:

- Connect signal and supply return wires close to output terminal block
- Use twisted pair as shown for best noise immunity

#### 3-wire Actuator

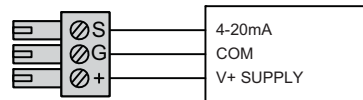

### Typical Actuator Hookup Details

#### 2-wire Control

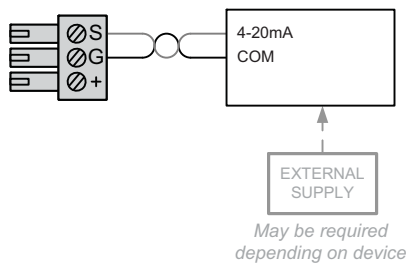

#### 3-wire 0-10V Actuator

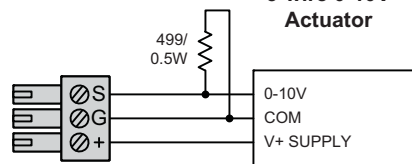

Note:

Place 499 Ohm shunt resistor close to actuator

## ClearLink Combined I/O Header

The ClearLink I/O header (labeled "Combined I/O" on the case) provides an alternative way to connect I/O devices to ClearLink's I/O points.

Note: This connector can alternately be used to take encoder input from Teknic PN CL-ENCDR-DFIN encoder board.

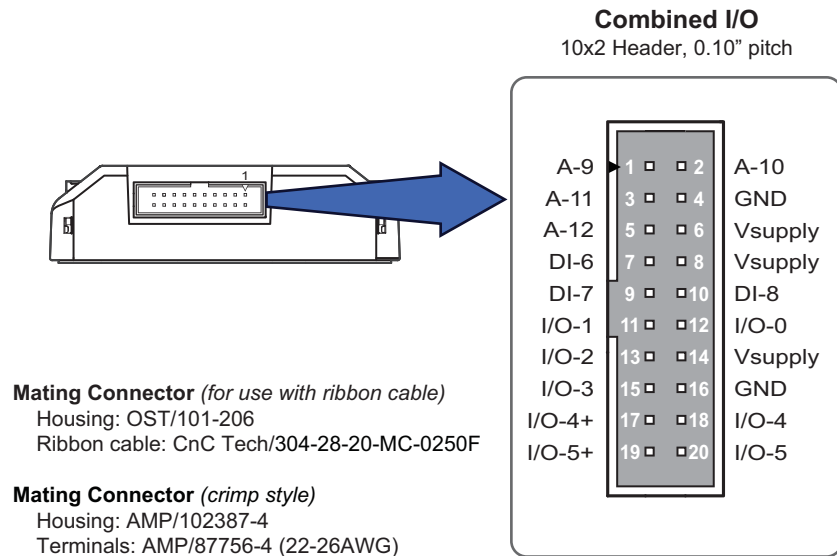

ClearLink I/O Header

## Wiring I/O Devices to CCIO-8

The CCIO-8 board connects to ClearLink's CCIO Port via standard Ethernet cable (CAT5e or better). CCIO-8 provides 8 additional I/O points per board. Up to (8) CCIO-8 boards can be connected to a ClearLink.

### IMPORTANT NOTES

- All CCIO-8 I/O points are electrically identical to ClearLink I/O points I/O-1, I/O-2, and I/O-3. ***The only functional difference is that the CCIO-8 points cannot output PWM signals.***
- CCIO-8 I/O points can be configured as either digital inputs or digital outputs.
- **Do not** hook up the accessory encoder input board to CCIO-8

### I/O-0 through I/O-7 configured as DIGITAL INPUTS

The wiring for all 8 of these I/O points (as inputs) is the same as the wiring for ClearLink [I/O-0 through I/O-5 configured as DIGITAL INPUTS](#)

### I/O-0 through I/O-7 configured as DIGITAL OUTPUTS

The wiring for all 8 of these I/O points (as outputs) is the same as the wiring for ClearLink [I/O-0 through I/O-5 configured as DIGITAL OUTPUTS](#)

### CCIO-8 Combined I/O Header

The CCIO-8 I/O header (labeled "Combined I/O" on the board) provides an alternate, functionally identical way to connect I/O devices to ClearLink's I/O points.

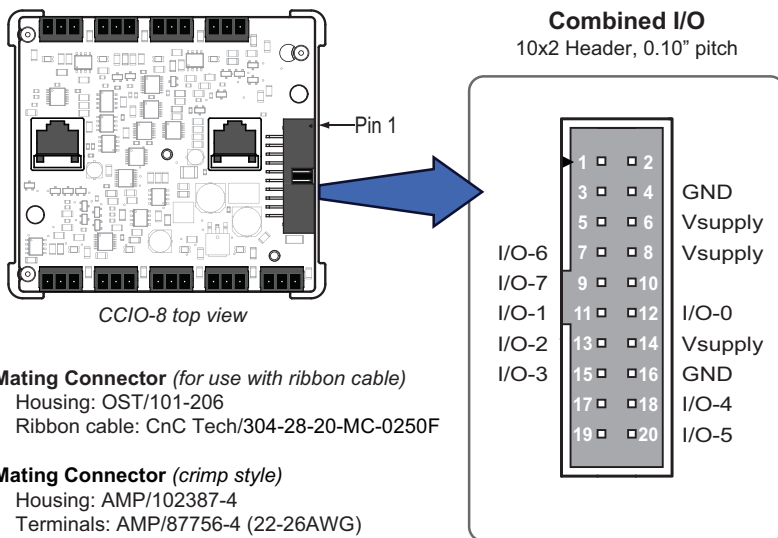

CCIO-8 I/O Header

## Motor Connectors (M-0, M-1, M-2, M-3)

ClearLink has four multi-function motor connectors that each have three (3) specialized outputs and one (1) specialized input. They are plug and play compatible with Teknic ClearPath motors, but are compatible with many third party servo/stepper drives.

ClearLink can be programmed to send either of the following types of control signals to the motor connectors:

- **Step & Direction** signals to ClearPath-SD series motors or compatible third-party servo or step motor drives.

OR

- **Digital control signals** to ClearPath-MC series (Motion Controller) motors.

**IMPORTANT:** Only one type of motor control method can be used on any given ClearLink Controller: **either Step and Direction or Digital Control signals, but not both types on the same ClearLink unit.**

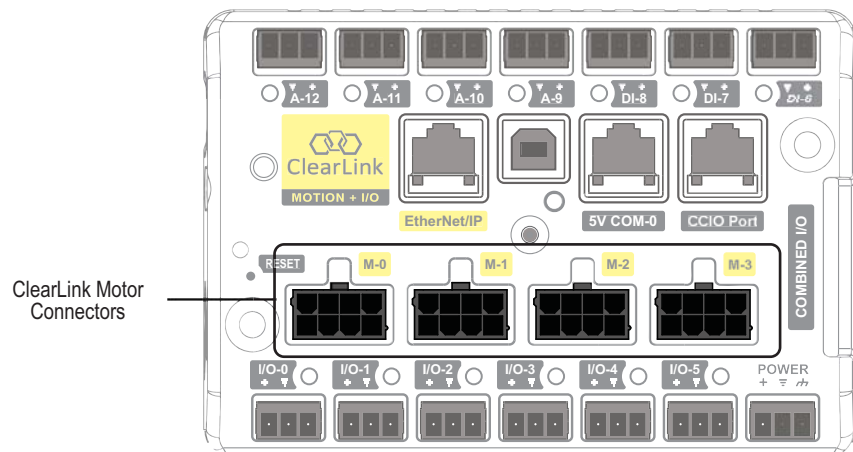

ClearLink motor connectors

**Note:** ClearLink motor connectors are designed to send and receive *low-power signals only*. **The motor connectors are not designed to directly power the phase windings of servo or stepper motors.**

## How to Wire a ClearPath Motor to ClearLink

ClearPath motors connect to ClearLink with an inexpensive Teknic controller cable. Part numbers are listed below.

### ClearPath Controller Cables

**Order from Teknic.** The quickest way to connect a ClearPath motor to ClearLink is with a ClearPath controller cable available from [teknico.com](http://teknico.com). See links below for information and pricing.

[CPM-CABLE-CTRL-MU120](#) 10 ft. ClearPath controller cable

[CPM-CABLE-CTRL-MM660](#) 55 ft. ClearPath controller cable

**Build your own.** ClearPath controller cables can also be built with off-the-shelf components available from electronics distributors like Dig-Key. See Appendix C for a full list of parts and tools required to build ClearPath controller cables.

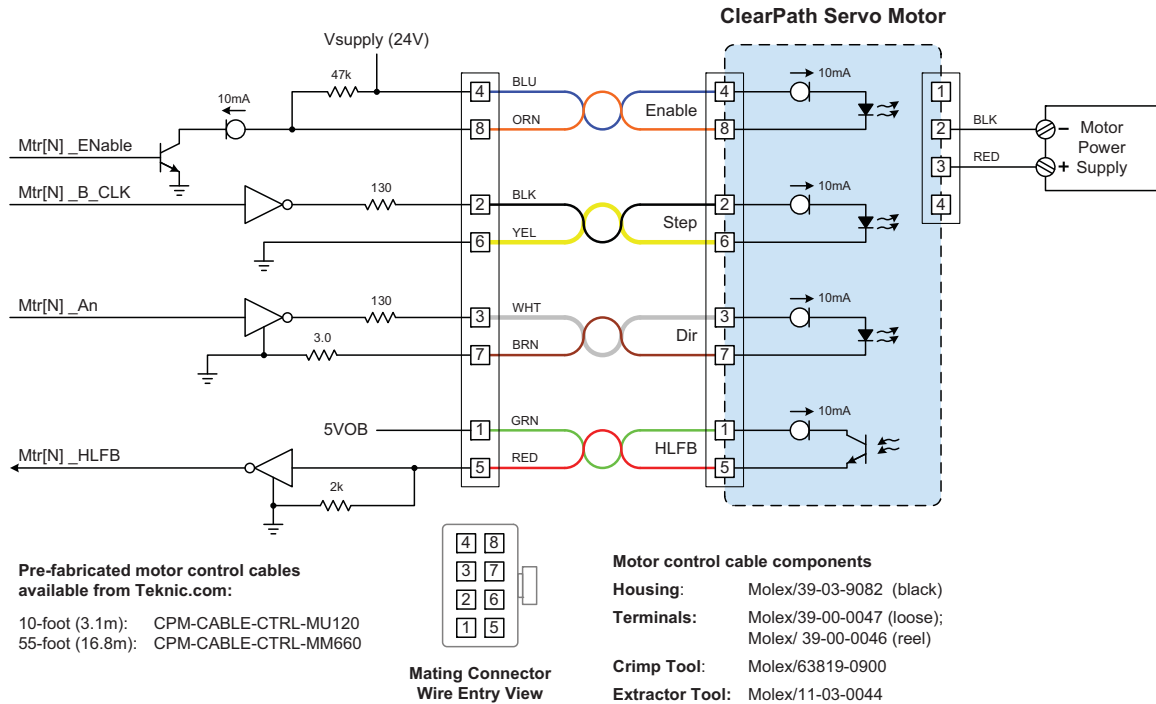

ClearPath motor connected to ClearLink

## Wiring a Stepper Motor Drive to ClearLink

Typical Stepper Motor Drive

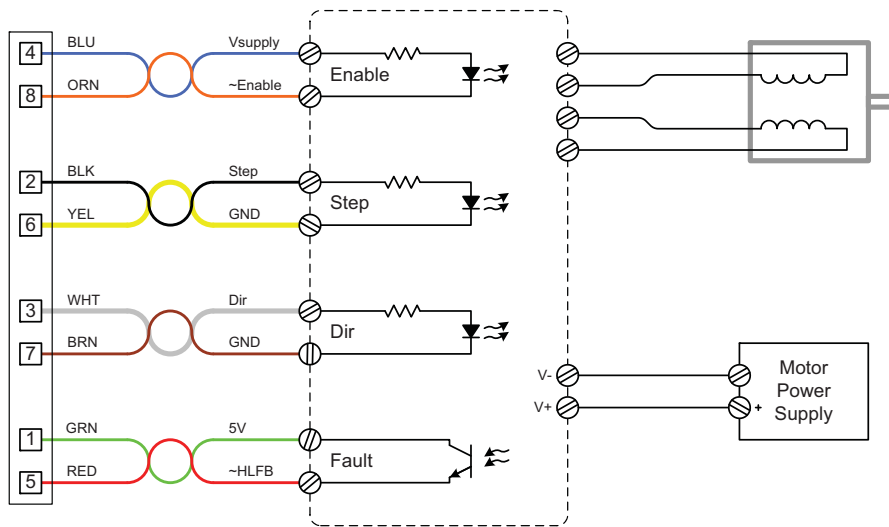

Stepper motor drive wired to ClearLink controller

## COM-0 (Serial COM Port)

ClearLink includes one multi-function serial port: COM-0. This port is accessed through an RJ-45 connector as shown below. The port is individually configurable for use with UART devices or RS-232 transceivers. The port includes a 5V power pin to power the remote device if needed.

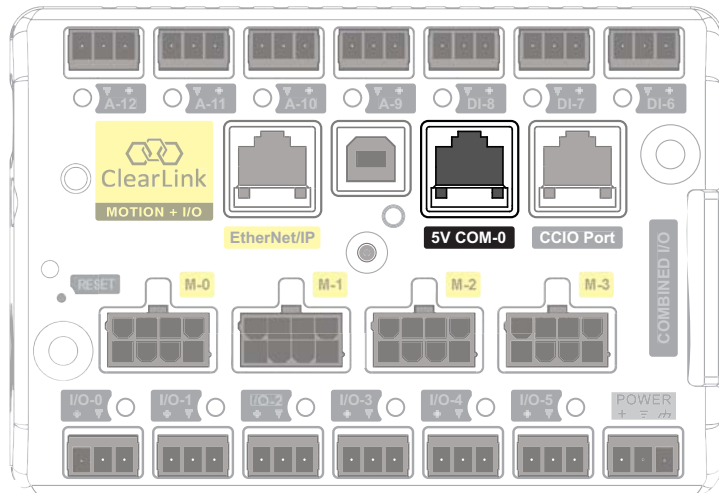

Serial Port COM-0

## COM-0 with 5V compatible RS-232 transceivers

### COM Port Equivalent Circuit

#### COM-0 For use with 5V compatible RS-232 transceivers

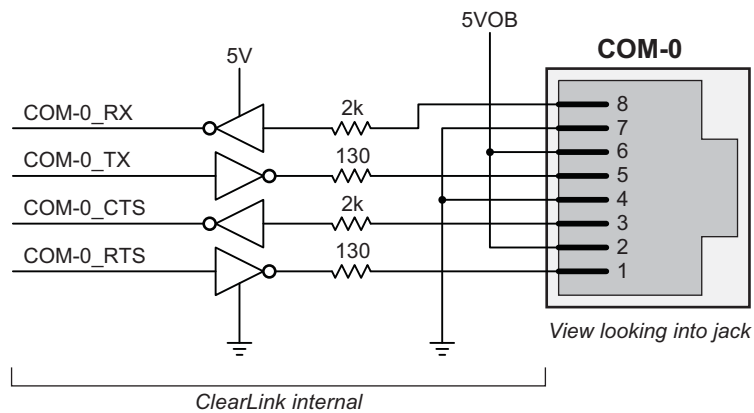

### Typical Hookup Details

**IMPORTANT: Mating serial ports must be compatible with 0-5V signals or a converter must be used.**

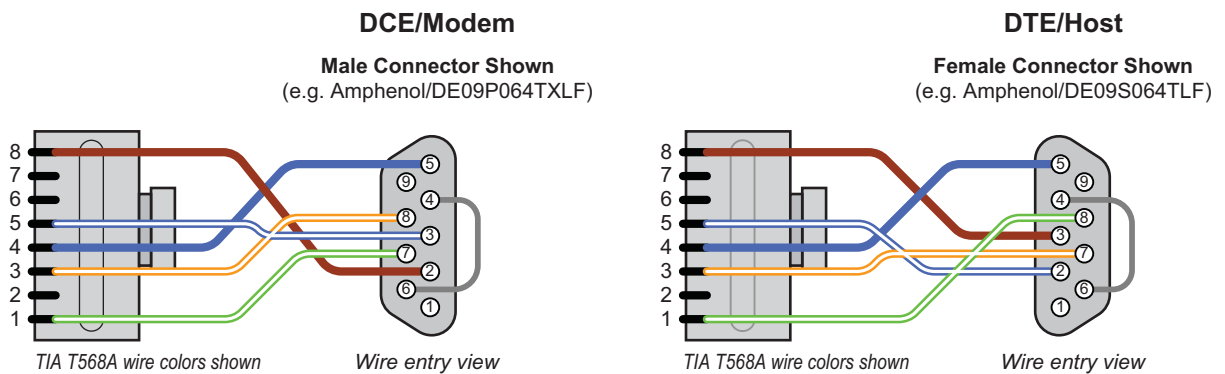

COM-0 configured for RS-232

## COM-0 configured for 5V logic UART devices

### COM Port Equivalent Circuit

#### COM-0 For use with 5V logic UART devices (non-inverting)

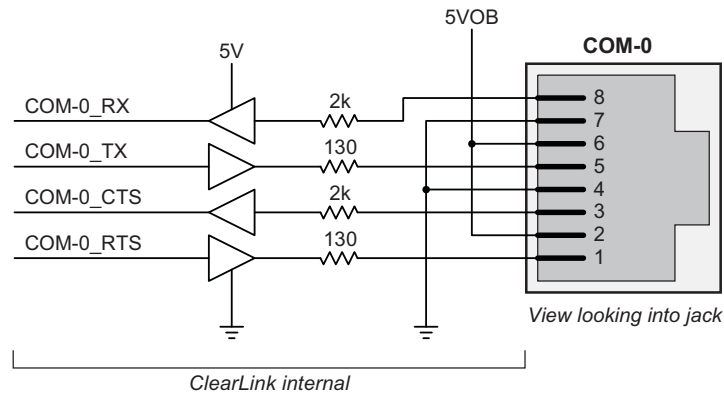

### Typical Hookup Details

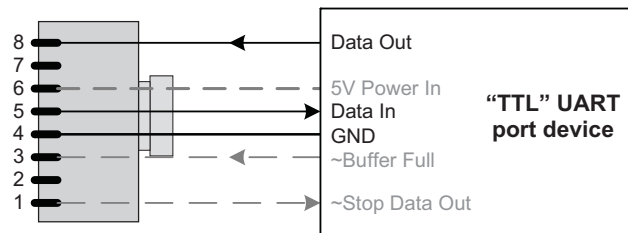

- 5VOB supplies 5V power for any loads connected to COM-0 connector
- Total current available from 5VOB is 450mA

### COM-0 configured for 5V UART devices

# CL-ENCNDR-DFIN Encoder Input Adapter Board

## Introduction

The CL-ENCNDR-DFIN encoder input adapter board lets you send externally generated encoder data to your ClearCore or ClearLink device. This accessory board is sold separately at Teknic.com.

**Note:** CL-ENCNDR-DFIN takes input from one, three-channel differential encoder only. ClearCore and ClearLink devices can receive input from one external encoder per unit.

**IMPORTANT:** When using CL-ENCNDR-DFIN, **do not connect external I/O devices to connectors DI-6, DI-7 and DI-8 on your ClearCore or ClearLink device.** Doing so will likely result in intermittent or nonexistent encoder feedback and may permanently damage your CL-ENCNDR-DFIN board.

**Index channel bypass.** If you do not need to use the index channel from your encoder, you may remove jumper P3 from the CL-ENCNDR-DFIN board. This will allow you to use DI-8 as a standard input on your ClearCore or ClearLink.

**Supported encoders.** Many third-party encoders with standard, 3-channel, differential output signals will work seamlessly with CL-ENCNDR-DFIN. Check the encoder manufacturers specifications to verify compatibility with CL-ENCNDR-DFIN before attempting to use.

For information on how to use external encoder data, see the software documentation for your ClearCore or ClearLink device.

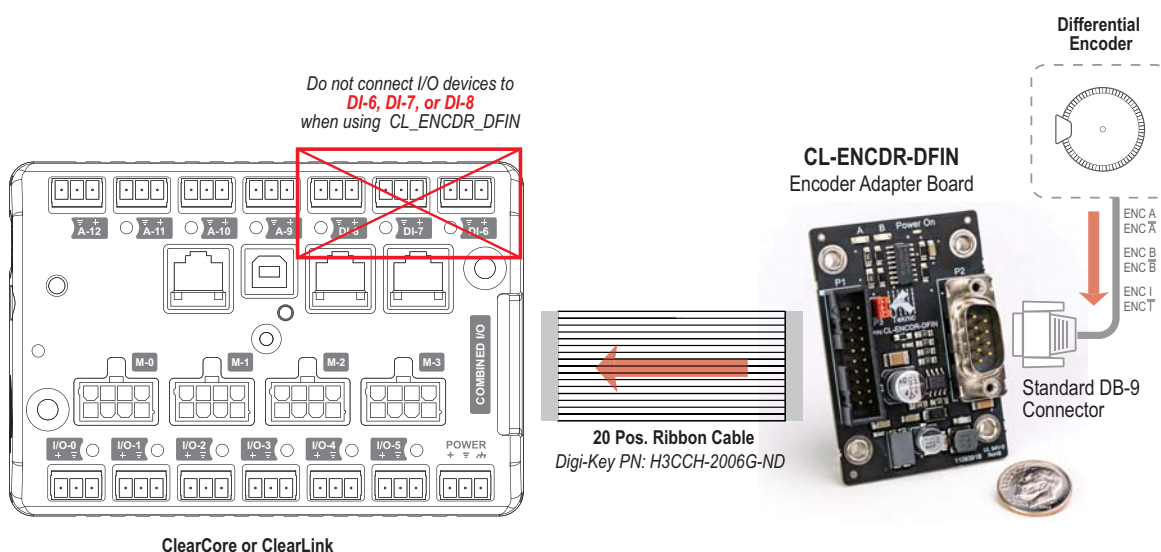

CL-ENCNDR-DFIN Encoder Input Adapter Board

## Connectors and Pinouts

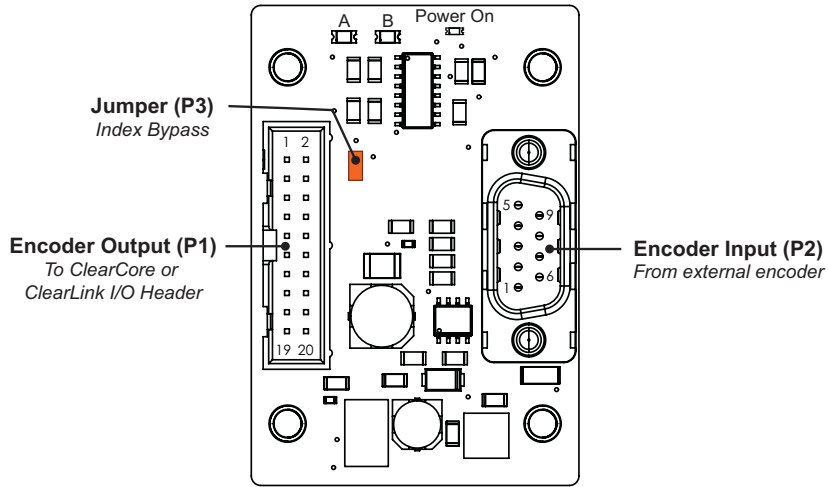

P1 - To ClearCore or ClearLink	
Pin	Signal Name
1	N/C
2	N/C
3	N/C
4	GND
5	N/C
6	N/C
7	Encoder A
8	N/C
9	Encoder B
10	Encoder I
11	N/C
12	N/C
13	N/C
14	V+
15	N/C
16	GND
17	N/C
18	N/C
19	N/C
20	N/C

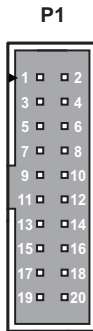

**Ribbon Cable Assembly**

20 Position Cable Assembly, Rectangular  
 Socket to Socket, 0.500" (152.40mm, 6.00")  
 Digi-Key PN: H3CCH-2006G-ND

**Mating Connector (for use with ribbon cable)**

Housing: OST/101-206  
 Ribbon cable: CnC Tech/304-28-20-MC-0250F

**Mating Connector (crimp style)**

Housing: AMP/102387-4  
 Terminals: AMP/87756-4 (22-26AWG)

P2 - Encoder Input	
Pin	Signal Name
1	GND
2	I+
3	B+
4	A+
5	5V
6	I-
7	B-
8	A-
9	GND

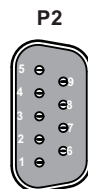

**Mating Connector**

Standard D-sub 9  
 shell, female contacts

## Dimensions

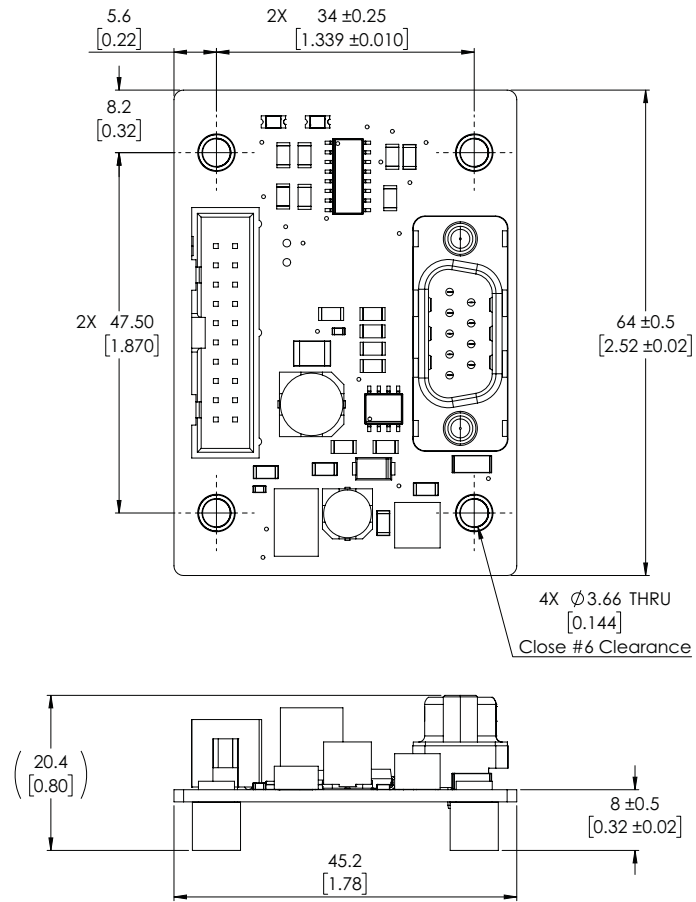

## Specifications

Specification	Min.	Typ.	Max.	Unit
Operating Temperature	-20		50	°C
Count Rate			2	MHz
5V Output Current			300	mA
A, B, I Signal Termination Impedance		470		Ω
Index Capture Delay		2		μS
Common Mode Input Voltage	-7		7	V
Input Differential Hysteresis		60		mV

## Appendix A: Specifications

### ClearLink Specifications

<b>Mechanical</b>	
Dimensions	5.0" x 3.5" x 1.0" (127mm x 88.9mm x 25.4mm)
Weight (with cover)	0.41 lbs (186 g)
Material	3mm thick polycarbonate cover, aluminum mount frame
<b>Electrical</b>	
Voltage Input	20-28 VDC (24VDC nominal)
Output Current Capability	I/O 0,1,2,3 - 375mA RMS, (750mA peak) I/O 4,5 - 750mA RMS, (1000mA peak)
Indicator LEDs for each input	yes
IP rating	IP20
Operating Temperature/Humidity	-20C to 50C, 0-90% non-condensing
Storage Temperature	-40C to 85C
Power Consumption	300mA @ 24VDC
Protection features	Overcurrent protection on all outputs Inductive clamping on all outputs Board master overvoltage and overcurrent protection ESD protection features on all I/O circuits
Capacitive load (max.)	Capacitance on I/O-0 through I/O-5 (and expansion port power pins) collectively may not to exceed 250uF.
<b>Processing/Communication</b>	
Total I/O	13 built-in I/O points, configurable as any combination of up to 13 digital inputs, 4 analog inputs, 6 digital outputs, and 1 analog output (4-20mA or 0-20mA). See I/O table below.  Another 64 digital I/O can be added by using optional 8-point I/O expansion modules (p/n CCIO-8).
Serial communication	1 multi-functional serial port that can be used as a UART or RS-232 at up to 115.2kBaud. Port hardware includes a 5V power pin.  Rates up to 2MBaud are achievable depending on cable length, slave transceiver circuit and grounding.
Ethernet	10Base-T/100Base-TX Ethernet. Accessed via standard RJ-45 jack. Use standard CAT5e cable or better.
Processor type and speed	32 bit floating point ARM M4F processor 120 MHz (p/n SAME53N19A)
Maximum Step Frequency	500kHz @ 50% duty cycle
Step Pulse Time	1uS <b>Note:</b> 3rd party Step & Dir drives must be able to accept 1uS pulses.
<b>Compliance</b>	
	CE, RoHS

## ClearLink I/O Function Table

Label	Digital Input	Digital Output <sup>1</sup>	0-10V Analog Input	4-20 mA Output <sup>2</sup>	Servos or Steppers	Encoder Input <sup>5</sup>
IO-0	yes	yes		yes		
IO-1	yes	yes				
IO-2	yes	yes				
IO-3	yes	yes				
IO-4	yes	yes				
IO-5	yes	yes				
DI-6	yes					yes
DI-7	yes					yes
DI-8	yes					yes
A-9	yes		yes			
A-10	yes		yes			
A-11	yes		yes			
A-12	yes		yes			
M-0					yes <sup>3</sup>	
M-1					yes <sup>3</sup>	
M-2					yes <sup>3</sup>	
M-3					yes <sup>3</sup>	
CCIO-8 <sup>4</sup>	yes	yes				

Note 1: All digital outputs are PWM capable (except for those on the CCIO-8 expansion board).

Note 2: This output can also provide 0-20mA, which is less commonly used.

Note 3: Each motor connector has 3 digital outputs (step, dir., enable) and 1 digital input.

Note 4: There are 8 of these I/O points on the CCIO-8 expansion module.

Note 5: Additional encoder board required, Teknic PN: CL-ENCNDR-DFIN.

## CCIO-8 Specifications

<b>Mechanical</b>	
Dimensions	3.6" x 3.28" x 1.0" (91.5mm x 83.3mm x 25.4mm)
Weight	3.18 oz. (90 g)
Material	Assembled circuit board with aluminum mount frame
<b>Electrical</b>	
Voltage Input	20-28 VDC
Output Current Capability	All I/O points are 375mA RMS (750mA peak)
Indicator LEDs for each input	Yes
IP Rating	IP20
Operating Temperature/Humidity	-20C to 50C, 0-90% non-condensing
Storage Temperature	-40C to 85C
Power Consumption	100mA@24V or 150mA@12V
Protection Features	Overcurrent protection on all outputs Inductive clamping on all outputs ESD protection features on all I/O circuits
<b>Processing / Communication</b>	
Total I/O	<p><b>Note:</b> All I/O points on CCIO-8 are electrically identical to I/O-1, I/O-2, and I/O-3 on ClearLink.</p> <p>8 built-in I/O points, configurable as any combination of up to 8 digital inputs and 8 digital outputs.</p> <p>A total of 8 CCIO-8 boards can be connected to one ClearLink, for a total of 64 additional digital I/O points.</p> <p>All I/O hardware is configured via software, i.e., there are no jumpers, DIP switches, trim-pots, etc.</p>
I/O Update Rate	0.2mS (1-2 boards), 0.4mS (3-4 boards), 0.6mS (5-6 boards), 0.8mS (7-8 boards)
Connectivity	ClearLink connects to CCIO-8 from its CCIO Port to the COM IN port of the first CCIO-8. Additional CCIO-8 boards must connect from COM OUT to COM IN. Use CAT5e cable (non-crossover) or better. Max cable length = 100 feet.
<b>Compliance</b>	
	CE, RoHS

---

**CCIO-8 I/O Function Table**

Label	Digital Input	Digital Output <sup>1</sup>	0-10V Analog Input	4-20 mA Output	Servos or Steppers	Encoder Input
I/O-0	yes	yes				
I/O-1	yes	yes				
I/O-2	yes	yes				
I/O-3	yes	yes				
I/O-4	yes	yes				
I/O-5	yes	yes				
I/O-6	yes	yes				
I/O-7	yes	yes				

*Note 1: Digital outputs on CCIO-8 are not PWM capable.*

## Appendix B: Mechanical Reference

### ClearLink Mounting and Clearance Dimensions

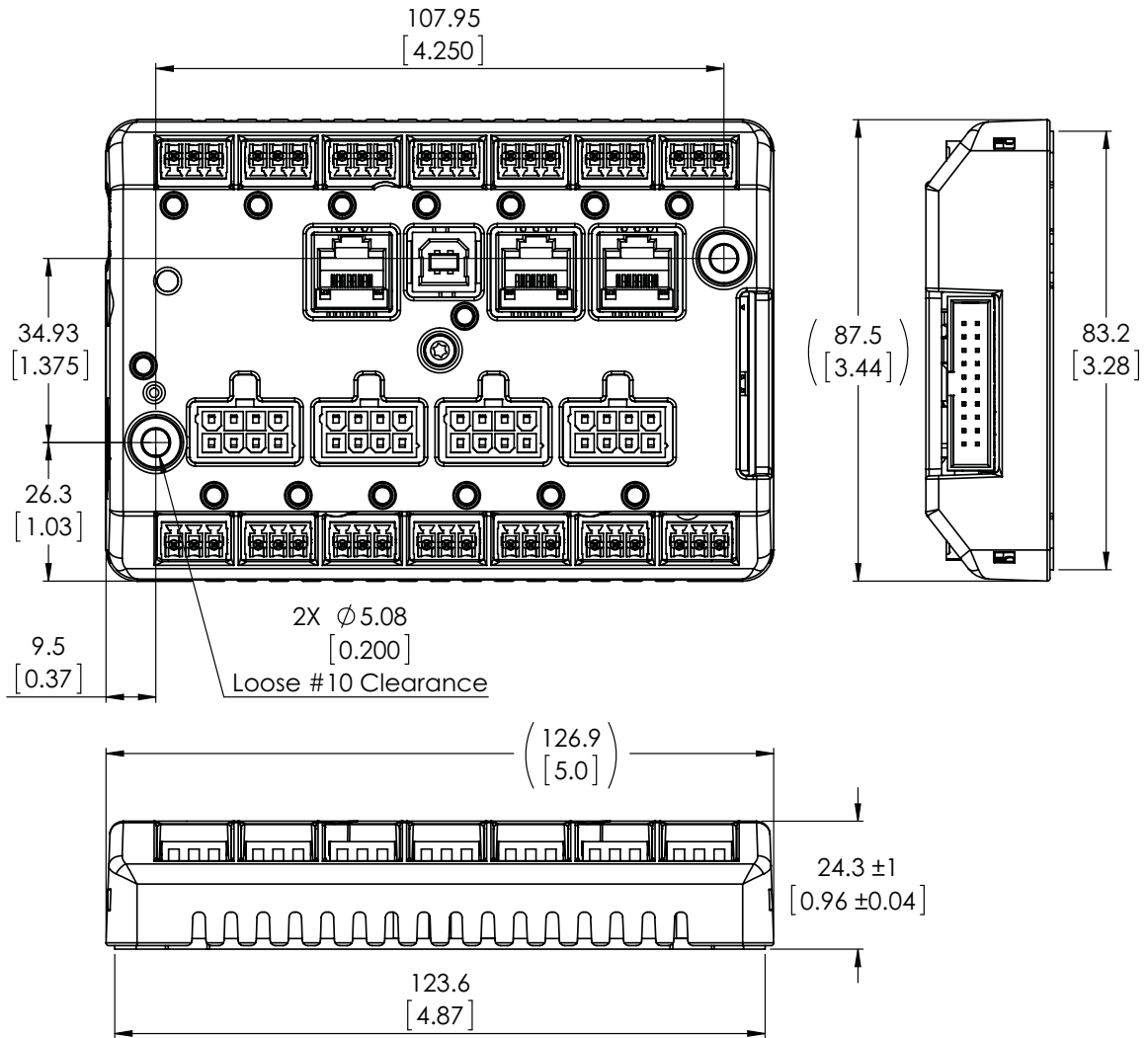

ClearLink Mounting Dimensions

#### ClearLink Mounting and Clearance Notes

- Leave a minimum of 1.5" (38.1mm) clearance around all ClearLink surfaces (except the mounting plate) for appropriate ventilation.
- Provide appropriate clearance for top and side-mounted cables. Note: some Ethernet and USB cables may require up to 2" clearance.

## CCIO-8 Mounting and Clearance Dimensions

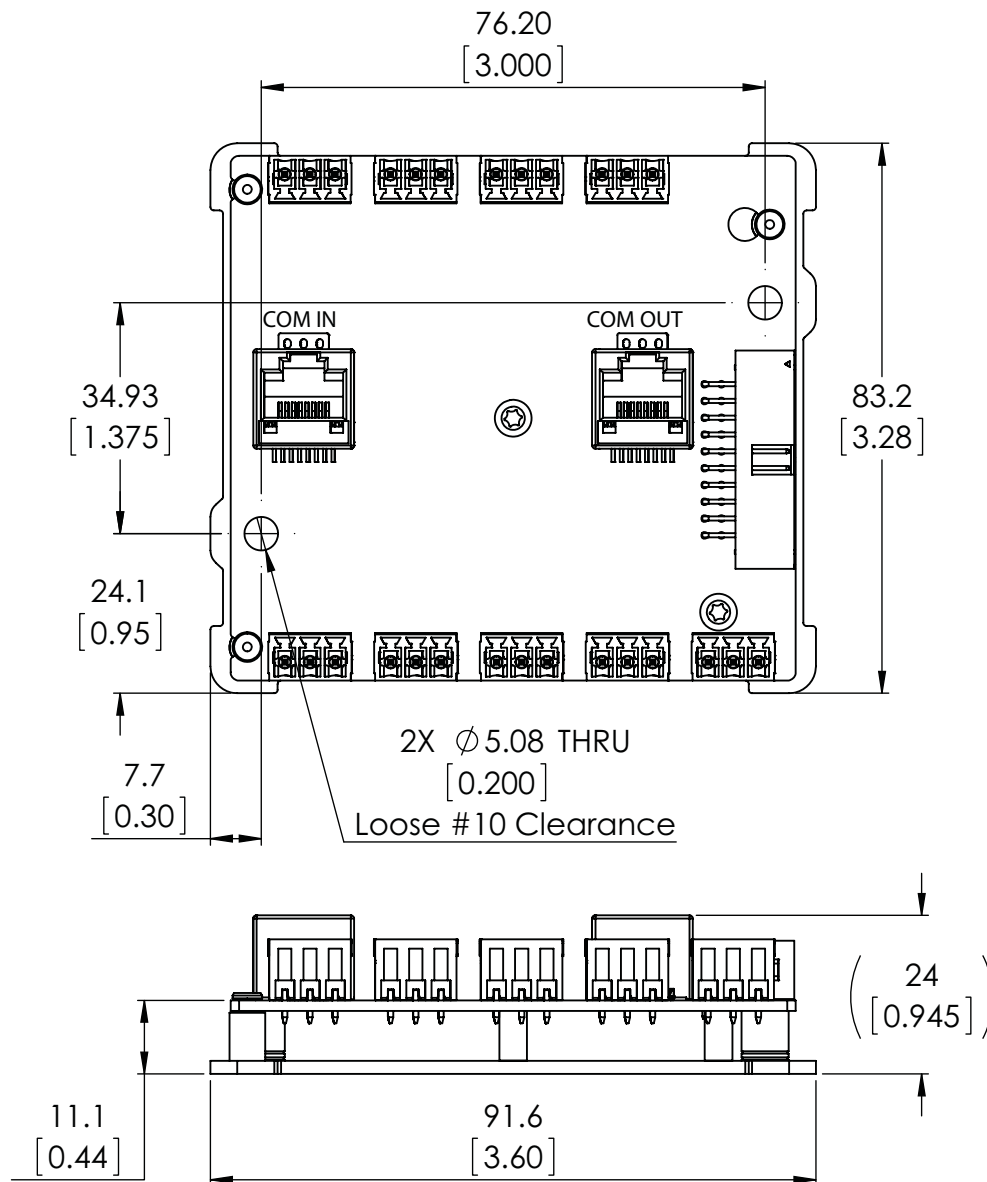

CCIO-8 Mounting Dimensions

### CCIO-8 Mounting and Clearance Notes

- Leave a minimum of 1.5" (38.1mm) clearance around all CCIO-8 surfaces (except the mounting plate) for appropriate ventilation.
- Provide clearance for top and side-mounted cables. Note: some Ethernet and USB cables may require up to 2" clearance.

## Appendix C: Mating Connectors and Terminals

Ref.	Mating Connector Description	Mating Connector or Cable PN	Terminal Description	Terminal PN	Tooling	Wire Gauge (AWG)
A	Screw terminal block, 3-position, 3.81mm pitch	Molex/0395105003	<b>OPTIONAL</b> Wire ferrule, 20-24 AWG, white	<b>OPTIONAL</b> American Electrical 1181050	<b>OPTIONAL</b> Crimp Tool American Electrical TRAP 22-10	20-24
B	Molex MiniFit-Jr, receptacle, 8-position	Molex part numbers: 39-01-2080 (natural, UL 94V-2) 39-01-3085 (black, UL 94V-2) 39-01-2085 (natural, UL 94V-0) 39-03-9082 (black, UL 94V-0)	Female crimp terminal, tin plate, 22-28 AWG	Molex/39-00-0046 (reel) Molex/39-00-0047 (loose)	<b>Crimp tool</b> Molex/63819-1000  <b>Extraction tool</b> Molex/11-03-0044	22
C	<b>Crimp style connector</b> , 20 position, free hanging, panel mount, 0.10" (2.54mm) pitch	TE/102387-4	Socket contact, gold plate, 22-26 AWG crimp	TE/87756-4	<b>Crimp tool</b> TE/169481-1	22-26
	<b>Ribbon cable connector</b> , 20-position, IDC, gold finish	<b>Connector</b> OST/101-206 <b>Ribbon cable stock</b> CnC Tech/304-28-20-MC-0250F	N/A	N/A	N/A	N/A

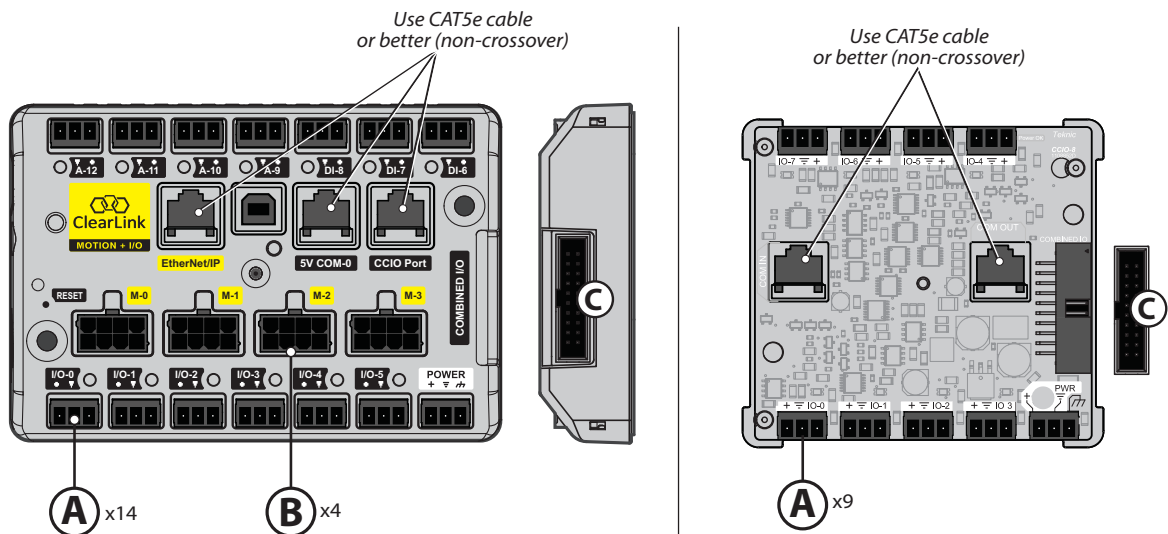

**Teknic, Incorporated**  
7650 Omnitech Pl  
Victor, NY 14564

© 2026 Teknic, Inc. All rights reserved.