



CLEARPATH USER MANUAL

MODELS MCVV, MCPV, SDSK, SDHP

NEMA 23 AND NEMA 34 FRAME SIZES

VERSION 3.30 / FEBRUARY 9, 2025

THIS PAGE INTENTIONALLY LEFT BLANK

TABLE OF CONTENTS

TABLE OF CONTENTS	3
TOP TIPS FOR CLEARPATH MC/SD USERS	9
QUICK START GUIDE	10
Please Read This Important Warning	10
Before You Begin (Suggested Viewing Material)	10
ClearPath Quick Setup.....	11
Required Items	11
Install ClearPath MSP Software	11
Secure Your Motor.....	11
Check DC Bus Power Polarity.....	12
Power Up Your ClearPath.....	12
Connect ClearPath to Your PC.....	13
Open ClearPath MSP (Motor Setup Program).....	13
Spin Your Motor Under MSP Software Control.....	14
Spinning a Model MCPV or MCVC.....	14
Spinning a Model SDHP or SDSK.....	19
DAMAGE WARNING: ClearPath Inputs/Outputs	22
If You Experience a Motor Shutdown or Warning.....	23
Auto-Tuning.....	24
Before You Seek Technical Help.....	25
SAFETY WARNINGS	26
Personal Safety Warnings.....	26
CE Compliance Warnings.....	26
General Disclaimer	27
INTRODUCTION	28
What is a ClearPath Motor?.....	28
Parts of a ClearPath Motor	30
Example Application: Absolute Positioning Mode	31
Summary of Operation	31
Overview: Configuring a ClearPath.....	32
Overview: ClearPath I/O	33
POWERING A CLEARPATH SYSTEM	34
Selecting a DC Bus Power Supply.....	34
ClearPath Operating Voltage	34
Notes on "Lower Voltage" Bus Power Supplies.....	35
Teknic Power Supplies.....	36
Before Powering a ClearPath.....	36
Power Supply Switching and Fusing	37
Basic Power Connection (2 motors)	38
Power Chaining (multiple motors).....	38
Using a POWER4-HUB	39
POWER4-HUB Overview Diagram	39
POWER4-HUB: Things to Know.....	40
POWER4-HUB: Compliance Notes.....	40
Parts of a POWER4-HUB	41
Connections For a Single POWER4-HUB System	42
Connections For a Dual POWER4-HUB System	43

Auxiliary (24V) Logic Power Supply	43
POWER4-HUB LED Codes	44
INPUTS AND OUTPUTS	45
I/O Connector Parts and Pinout.....	45
ClearPath Inputs	46
Input Current Draw	46
How Inductive Loads Can Damage ClearPath I/O	47
How to Protect Your Motor From Inductive Kickback ...	47
The Enable Input	48
Inputs A and B: The Control Inputs	48
Input Wiring	49
ClearPath Output (HLFB).....	50
HLFB Output Wiring Examples	51
HLFB Modes: Common To All ClearPath Op Modes.....	54
HLFB Modes: For ClearPath Positioning Modes.....	56
HLFB Modes: For ClearPath Velocity Modes	58
HLFB Output: For ClearPath Torque Modes	60
USER SOFTWARE (CLEARPATH MSP).....	61
Section Overview.....	61
MSP Minimum System Requirements	61
Installing MSP.....	61
Communicating With ClearPath Via MSP	61
Items Required for Communication Setup	62
First-Time Communication Setup.....	62
Tour of ClearPath MSP Software.....	63
Main UI Overview.....	63
Mode Controls.....	63
Torque Limit Setup	64
Dashboard.....	69
MSP Menus	70
MSP Software Scope	82
Overview	82
Scope Features	82
Scope User Interface & Controls	83
OPERATIONAL MODES: MCV C AND MCPV	90
Table of Operational Modes: Models MCV C and MCPV	90
Follow Digital Torque Command (Bi-Polar PWM Command)...	92
Mode Description	92
I/O Functions.....	92
Mode Controls.....	93
Setting a PWM Deadband.....	95
Follow Digital Torque Command (Unipolar PWM Command)..	96
Mode Description	96
I/O Functions.....	96
Mode Controls.....	97
Follow Digital Torque Command (Frequency Command)	98
Mode Description	98
I/O Functions.....	98
Mode Controls.....	99
Ramp Up/Down To Selected Velocity	100

Mode Description	100
I/O Functions.....	100
Mode Controls.....	101
Spin On Power Up	102
Mode Description	102
I/O Functions.....	102
Mode Controls.....	103
Manual Velocity Control.....	104
Mode Description.....	104
I/O Functions.....	104
Mode Controls.....	106
Description of Encoder/Knob Settings	106
Follow Digital Velocity Command (Bi-Polar PWM Command with Inhibit)	108
Mode Description	108
I/O Functions.....	108
Mode Controls.....	109
Setting A PWM Deadband (Optional)	111
Follow Digital Velocity (Bipolar PWM Command with Variable Torque).....	112
Mode Description	112
I/O Functions.....	112
Mode Controls.....	114
Follow Digital Velocity Command (Unipolar PWM Input)	115
Mode Description	115
I/O Functions.....	115
Mode Controls.....	116
Follow Digital Velocity Command (Frequency Input).....	118
Mode Description	118
I/O Functions.....	118
Mode Controls.....	119
Move to Sensor Position	120
Mode Description	120
I/O Functions.....	121
Mode Controls.....	122
Move to Absolute Position (2-Position, Home to Switch)	123
Mode Description	123
I/O Functions.....	123
Mode Controls.....	124
Move to Absolute Position (4-Position, Home to Hard Stop) ..	125
Mode Description	125
I/O Functions.....	125
Mode Controls.....	127
Move to Absolute Position (16-Position, Home to Hard Stop) ..	128
Mode Description	128
I/O Functions.....	128
Mode Controls.....	129
Move Incremental Distance (4-Distance, Home to Hard Stop) ..	130
Mode Description	130
I/O Functions.....	130
Mode Controls.....	132

Move Incremental Distance (2-Distance, Home to Hard Stop)	133
Mode Description	133
I/O Functions.....	133
Mode Controls.....	134
Move Incremental Distance (2-Distance, Home-to-Switch)	135
Mode Description	135
I/O Functions.....	135
Mode Controls.....	136
Move Incremental Distance (1-Distance, Home-to-Switch).....	137
Mode Description	137
I/O Functions.....	137
Mode Controls.....	138
Pulse Burst Positioning.....	139
Mode Description	139
I/O Functions.....	139
Mode Controls.....	140
Multi-Sensor Positioning: Bi-directional (Home to Hard Stop)	141
Mode Description	141
I/O Functions.....	141
Mode Controls.....	142
Multi-Sensor Positioning: Unidirectional (Sensorless Homing)	143
Mode Description	143
I/O Functions.....	143
Mode Controls.....	144
Multi-Sensor Positioning: Unidirectional (Home to Sensor) ...	145
Mode Description	145
I/O Functions.....	145
Mode Controls.....	146
Follow Digital Position Command: Unipolar PWM Command	147
Mode Description	147
I/O Functions.....	147
Mode Controls.....	148
Follow Digital Position Command: Frequency Command	149
Mode Summary.....	149
I/O Functions.....	149
Mode Controls.....	150
OPERATIONAL MODES: SDSK AND SDHP	151
Step & Direction.....	151
Mode Description	151
I/O Functions.....	151
Mode Controls.....	152
Step & Direction Pulse Timing Information	153
Step Input Timing Problems	154
Quadrature Input.....	156
Mode Description	156
I/O Functions.....	156
Mode Controls.....	158
APPENDIX A: TROUBLESHOOTING	159
LED Blink Codes	159

APPENDIX B: MECHANICAL INSTALLATION	163
Mounting Dimensions: POWER4-HUB.....	163
Mounting Dimensions: ClearPath NEMA 34.....	164
Mounting Dimensions: ClearPath NEMA 23.....	165
Motor Mounting Considerations.....	166
Connecting ClearPath to a Mechanical System.....	166
Motor Connection: General Tips and Guidelines	166
Notes on Coupling Selection.....	168
Installing Pulleys and pinions	169
About End-of-Travel Stops.....	170
Hard Blocks.....	170
Elastomeric (rubber) Stops	170
Pneumatic (dashpots).....	170
End Stops and Hard Stop Homing.....	170
Fan Mounting and Cooling.....	171
APPENDIX C: MATING CONNECTORS AND CABLE PINOUTS	172
Mating Connector Information	172
Cable Pinouts	173
Control Cable: CPM-CABLE-CTRL-MU120	173
Control Cable: CPM-CABLE-CTRL-MM660	173
Control Cable: Molex Brand (2 meters and shorter)	174
Power Cable: CPM-CABLE-PWR-MM660	175
Power Cable: CPM-CABLE-PWR-MS120	175
APPENDIX D: COMMON SPECIFICATIONS	176
APPENDIX E: GROUNDING AND SHIELDING	177
Protective Earth (PE) Connection	177
Grounding and Shielding.....	177
Power Returns	178
APPENDIX F: CIRCUIT SCHEMATICS	179
POWER4-HUB Schematic (simplified).....	179
APPENDIX G: CLEARPATH PART NUMBER KEY	180
APPENDIX H: MISCELLANEOUS TOPICS	181
Homing	181
Introduction.....	181
Terms Used In This Section.....	182
Homing Settings	183
Typical Homing Sequences.....	189
Precision Homing	191
Homing Methods Listed by Operational Mode.....	193
MSP Motion Generator.....	194
Motion Generator Controls	194
Encoder and Input Resolution	196
Introduction.....	196
Terms used in this section	196
Native Resolution	196
Positioning Resolution.....	197
Input Resolution Setting in MSP.....	197
RAS and g-Stop (Vibration and Resonance Suppression).....	199

RAS (Regressive Auto-Spline)	199
g-Stop Tuning	202
Other Product Notes	203
ClearPath EMC Instructions.....	203
APPENDIX I: LOGIC POWER SUPPLY SIZING	204

TOP TIPS FOR CLEARPATH MC/SD USERS

These tips apply to the fractional power ClearPath-MC and ClearPath-SD motors covered in this document.

TOP TIPS

- ✓ **Noise at Power Up?** The brief buzzing sound you hear upon first power up is the motor initializing itself. This is normal (and necessary).
- ✓ **Motor Killer!** Never reverse DC bus voltage polarity (positive vs. negative) to your ClearPath motor. Doing so will irreparably damage the motor. [More...](#)
- ✓ **Protect Your ClearPath I/O!** Brakes, solenoids, contactors (any coil-actuated device) that are wired in parallel with your ClearPath inputs can destroy them via inductive kickback. Diodes save [motor] lives. [More...](#)
- ✓ **USB Cables Matter.** Use only Hi-Speed USB data cables to communicate with your ClearPath motor. "Charger only" cables won't work. [More...](#)
- ✓ **Prevent USB Connector Damage!** Avoid yanking, twisting, or tripping on a USB cable that is connected to a ClearPath USB port. This can break the physical connector (and your ability to communicate with the motor).
- ✓ **Cover your motor's USB port** with the included silicone plug when the port is not in use. This will keep out dust, chips, liquids, etc.
- ✓ **Yellow Blink Code?** This indicates a shutdown of some type has occurred. 1) Look up motor blink codes in the user manual (see [Appendix A](#)). 2) Connect to your motor's USB port to view shutdown messages using the MSP software.
- ✓ **Auto-Tune Fully Loaded.** Auto-Tune with your motor connected to the mechanics exactly as it will run during normal operation. Note: The default motor tuning file that comes with your motor is designed for no-load operation.
- ✓ **Use different power supplies** for main DC bus power versus low power logic (inputs and outputs). It may be tempting to use the same supply for 24VDC applications, but avoid doing so.
- ✓ **Step Timing Shutdowns?** (Applies to SD motors and MC motors in Pulse Burst mode.) Install resistors on the step and direction outputs of controllers with transistor outputs. [More...](#)
- ✓ **Prevent Water Ingress.** Never submerge your motor in water or other liquids. Avoid exposing the motor to high-pressure sprays.

QUICK START GUIDE

This section was designed to help you get your ClearPath motor up and running quickly and safely.

ITEMS COVERED IN THIS SECTION

- How to download and install *ClearPath MSP* (setup and configuration software)
- How to power up your ClearPath motor
- How to connect your ClearPath to a PC and establish communication
- How to spin your unloaded¹ ClearPath motor under MSP software control

PLEASE READ THIS IMPORTANT WARNING

Always use caution and common sense when handling motion control equipment. Even the smallest ClearPath motor is powerful enough to seriously damage fingers, turn a tie into a noose, or tear out a patch of hair and/or scalp in just a few milliseconds (by comparison, it takes between 100 and 400 milliseconds to blink). We're not trying to scare you (...OK maybe a *little*) but we do want all ClearPath users to stay safe and *fully intact*. **These devices are very powerful and can be extremely dangerous if used carelessly.** Please read and understand all safety warnings in the ClearPath User Manual before operating a ClearPath motor.

BEFORE YOU BEGIN (SUGGESTED VIEWING MATERIAL)

Check out the ClearPath overview video. This is a great way to learn about ClearPath motors (and Teknic as well). Note: There's a great ClearPath demonstration at time reference 3:50.

Try watching a few ClearPath operational mode videos. There is a separate short video for most ClearPath operational modes. Each video includes an overview of the operating mode, a brief discussion of software controls and settings, and a demonstration featuring a real mechanical system.

ClearPath Video Links

<https://www.teknic.com/watch-video/>

<https://www.youtube.com/channel/UC4Q91tGO8oQMSHyY1SoHrtg>

¹ Unloaded means *with nothing attached to the motor shaft*. ClearPath comes factory preconfigured for unloaded operation. **ClearPath must be tuned** whenever it is connected to a new type of mechanical system.

CLEARPATH QUICK SETUP

REQUIRED ITEMS

- ClearPath motor
- DC Bus Power supply (with cables) 24-75 VDC
- Windows PC (Win 7, 8.1, 10, 11)
- USB cable (USB type-A to micro-B)
- Clamp or vise

INSTALL CLEARPATH MSP SOFTWARE

MSP is a free download from Teknic's website. Click [here](#) for a direct link. To install MSP, save the zip file to your local computer, extract the .exe file, and run it.

SECURE YOUR MOTOR

Injury Warning: To prevent broken toes, and damage to your motor, always secure your ClearPath motor to a stable, flat, level work surface before operating it; otherwise, your motor will buck and jump during operation. A “quick-grip” style clamp or vise is recommended.

Tip: If you use a vise to secure your motor, you can preserve the motor's finish by taping the vise jaws or by placing scrap cardboard or wood between the vise and the motor body. Do not over tighten vise.

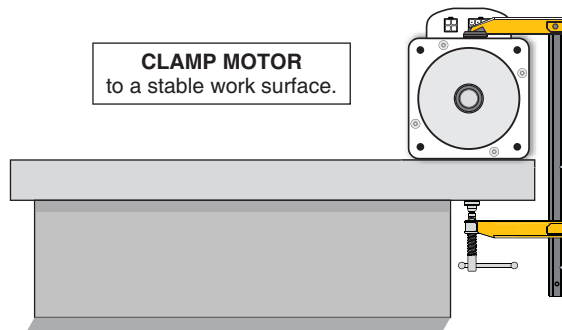

Clamp it!

CHECK DC BUS POWER POLARITY

Damage Warning: Reversing DC power polarity to your ClearPath motor *will* permanently damage it.

Before you connect DC power to your ClearPath motor, use a voltmeter to verify that DC bus power is wired with the proper polarity. This is particularly important if the cables were not made by Teknic.

For Teknic DC power cables (PN: CPM-CABLE-PWR-MS120), test DC voltage at pins 3 and 2 as shown below (pin 3 is v+ and pin 2 is GND). This should display a positive voltage reading.

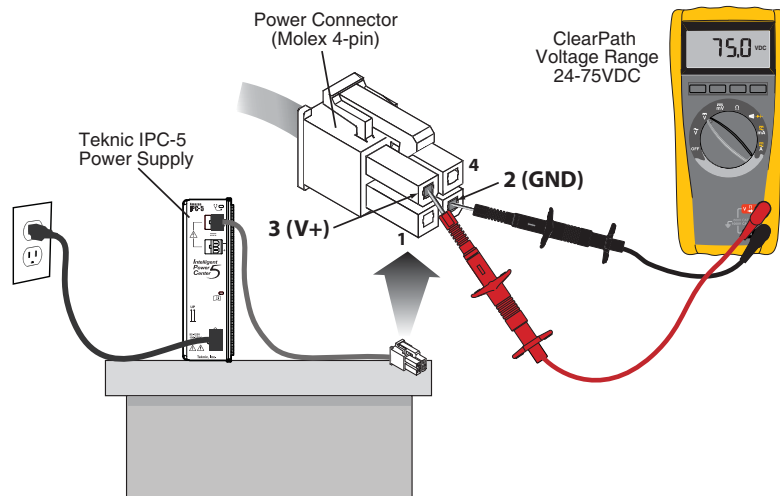

Polarity test from pin 3 (V+) to pin 2 (GND) shows a positive 75 volts

POWER UP YOUR CLEARPATH

1. Begin with the power supply turned off or unplugged.
2. Connect the DC power cable from the power supply to the ClearPath motor's 4 pin connector.
3. Turn on (plug in) the power supply.

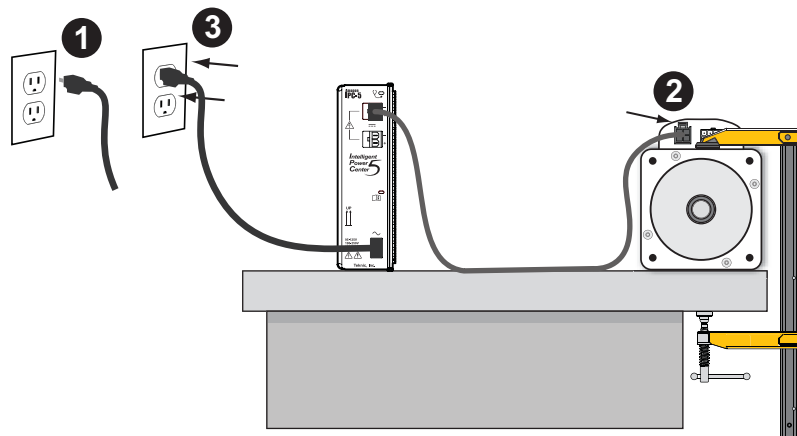

Power up sequence

CONNECT CLEARPATH TO YOUR PC

Connect ClearPath to a USB port on your PC with a high quality USB type-A to micro B cable (Teknic PN: **CPM-CABLE-USB-120**). If this is a first-time connection, wait for ClearPath to automatically install its driver software before proceeding. This should only take a minute or so.

Damage Warning: Do not use USB cables of unknown origin (e.g. found in a junk drawer) with your ClearPath. Non-standard cables may be incompatible with ClearPath, and may even damage your motor.

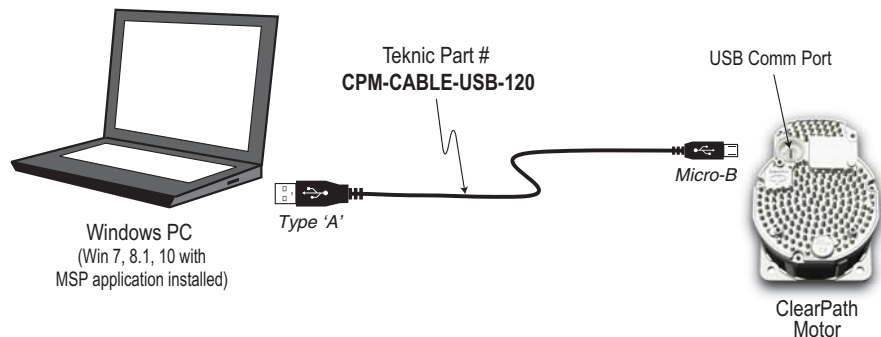

Connect ClearPath to your PC

OPEN CLEARPATH MSP (MOTOR SETUP PROGRAM)

After you open MSP, ClearPath will attempt to establish communication with your PC. If all is well, you will briefly see a window like the one below.

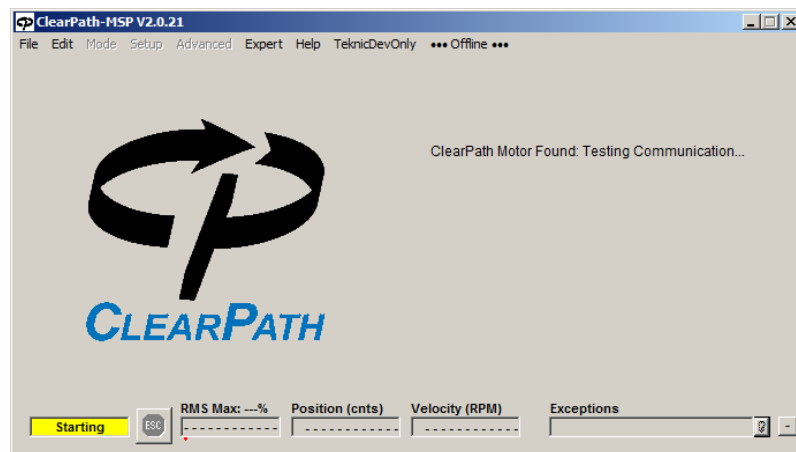

Open MSP (Motor Setup Program)

SPIN YOUR MOTOR UNDER MSP SOFTWARE CONTROL

The best way to learn about a ClearPath operational mode is to try it under software control. MSP includes simple software controls that emulate hardware inputs and outputs, so you can try different modes of operation without wiring a single switch or sensor.

Note: ClearPath Soft Controls are great for test, development and training, but are not meant to be used as the control system for your machine.

SPINNING A MODEL MCPV OR MCVC

Spinning Step & Direction models (SDSK and SDHP) is covered in the next section.

For models MCPV and MCVC we will use the mode *Ramp Up/Down To Selected Velocity*. Feel free to try any mode available in the Mode drop down menu. Each mode is described in its own section later in this manual.

1. Open MSP software. The "Tuning" dialog will appear. For now select the bottom option (run with no load).

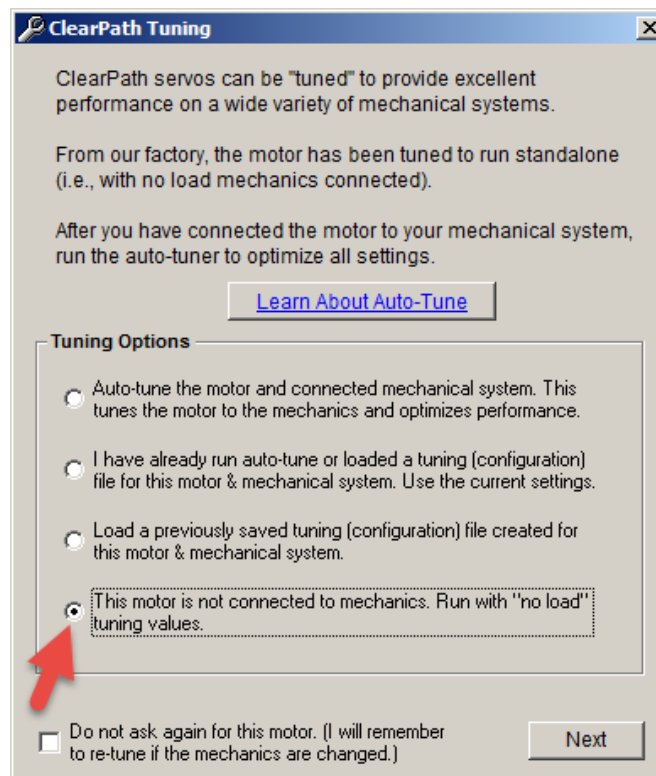

2. From the MSP menu, select **Setup>Units>Counts; RPM; RPM/s**. This just tells MSP how to display distance, velocity, and acceleration.

3. Select **Mode>Velocity>Ramp Up/Down to Selected Velocity**.

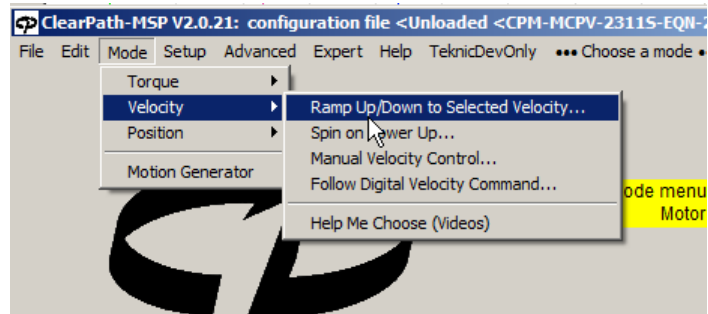

4. A dialog window will open (see below). Please read all of the text presented, especially if you're unfamiliar with how the op mode works. Click OK to proceed.

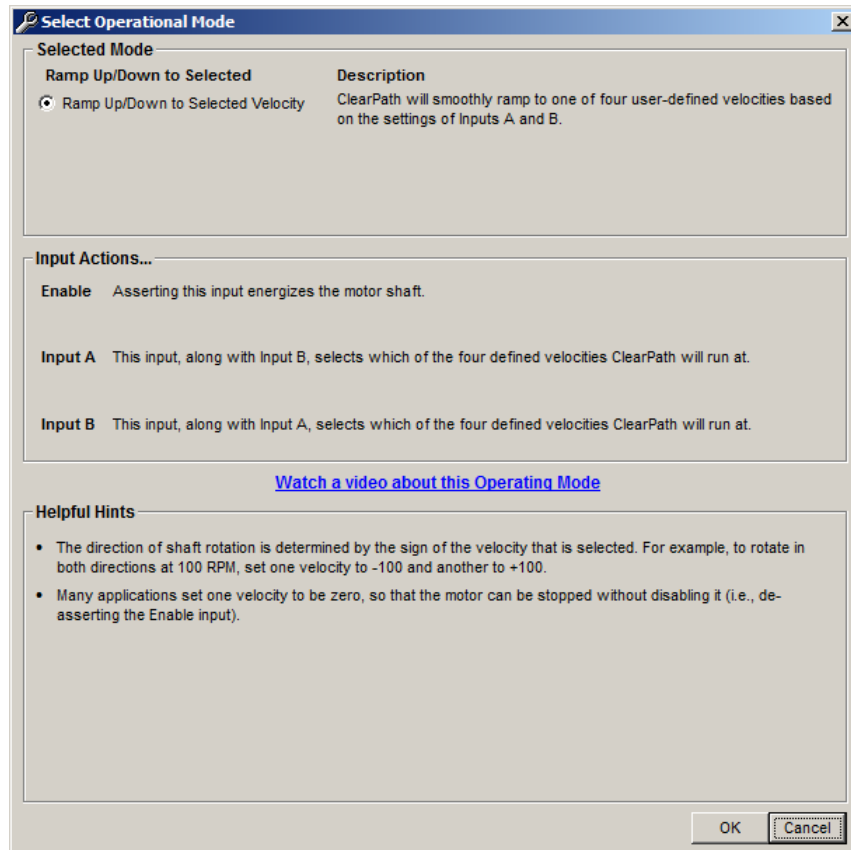

- The **mode controls** window will appear as shown below. To follow along, enter the settings as they appear below.

Enter target velocity for each input state here.

Click to open Torque Limit Setup dialog.

Velocity Selection Setup (RPM)

1) A off B off 2) A on B off 3) A off B on 4) A on B on

0.00 +10.00 -100.00 +500.00

Accel (RPM/s) 5,000

Decel (RPM/s) 5,000

Profile Conversion RAS™ 21 ms

Torque Limit OVR Setup...

Torque Override Indicator
When lit, the main torque limit is being overridden by a secondary, user-set torque limit (e.g., when an axis is homing, the main torque limit may be overridden by the separate homing torque limit setting).

Enter maximum desired motor acceleration rate.

Check here to set motor deceleration rate to same value as acceleration rate.

Enter maximum desired motor deceleration rate.

Adjust settings for RAS™ (or optional g-Stop™) to convert standard trapezoidal move profiles into profiles that reduce noise, resonance, and vibration.

Hardware Input Status LEDs
Light = Input asserted (on)
Dark = Input de-asserted (off)

Displays commanded velocity (when using hard inputs).

Inputs and Commands

Enable On/Off Input A V-sel A Input B V-sel B

Commanded Velocity (RPM) +20.

Servo On Output Servo On

Override Inputs

Check to turn on Soft Controls. Override cannot be activated when ClearPath is hardware enabled.

Soft Inputs and LEDs emulate hardware inputs. For use only when Soft Controls are active.
Caution: motor may spin when enabled.

Displays commanded velocity (when using soft inputs).

Displays HLFB output status.

Mode Controls for mode "Ramp Up/Down to Selected Velocity"

- Click the Override Inputs checkbox. This turns on the software controls. You may notice that the other Soft Controls are no longer grayed out.

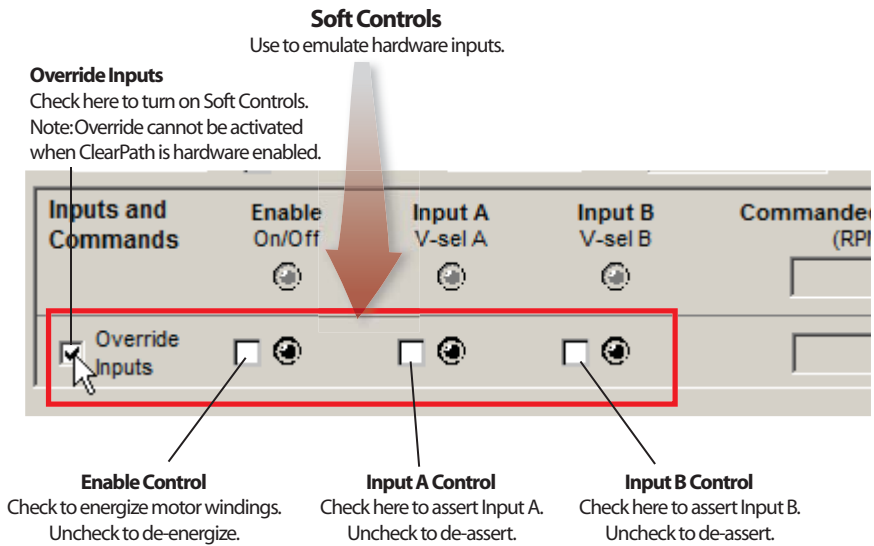

Check "Override Inputs" box to turn on Soft Controls

- Safety check!** Before proceeding, make sure that the motor is securely clamped down and the shaft is safely positioned away from fingers, clothing, hair, cables, etc.
- Click the Enable Control. **Caution: the motor is now energized and capable of motion.**

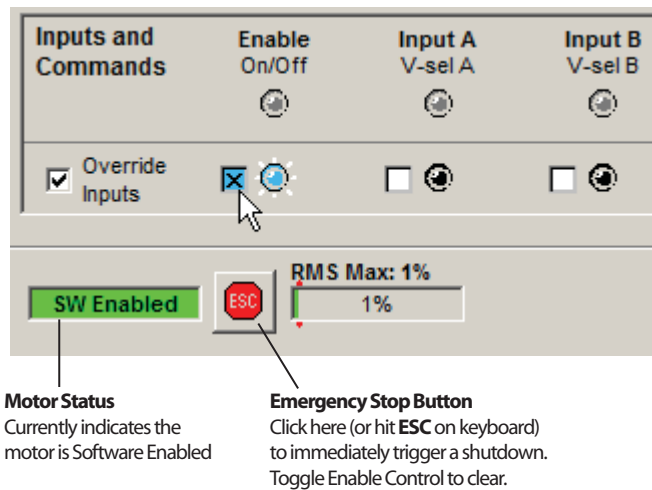

Enable ClearPath using Soft Controls

9. **Make some moves.** With the motor enabled, change Inputs A and B as shown below to spin at different velocities. Feel free to experiment. Try changing velocities, accelerations, and RAS settings.

Velocity Selection Setup (RPM)

1) A off B off	2) A on B off	3) A off B on	4) A on B on
0.	+10.	-100.	+500.

Inputs and Commands	Enable On/Off	Input A V-sel A	Input B V-sel B	Velocity	Direction
<input checked="" type="checkbox"/> Override Inputs	<input checked="" type="checkbox"/>	<input type="checkbox"/>	<input type="checkbox"/>	0 RPM	A off B off
<input checked="" type="checkbox"/> Override Inputs	<input checked="" type="checkbox"/>	<input checked="" type="checkbox"/>	<input type="checkbox"/>	+10 RPM	A on B off
<input checked="" type="checkbox"/> Override Inputs	<input checked="" type="checkbox"/>	<input type="checkbox"/>	<input checked="" type="checkbox"/>	-100 RPM	A off B on
<input checked="" type="checkbox"/> Override Inputs	<input checked="" type="checkbox"/>	<input checked="" type="checkbox"/>	<input checked="" type="checkbox"/>	+500 RPM	A on B on

Change velocity and direction by checking Inputs A and B

ADDITIONAL NOTES

- The direction of shaft rotation is set by entering a "+" or "-" sign in front of the velocity settings (see top of figure above). "+" will cause CCW rotation, "-" will cause CW rotation.

SPINNING A MODEL SDHP OR SDSK

Note: Spinning ClearPath models MCV C and MCPV is covered in the previous section.

ClearPath SD models have one mode: *Step and Direction*. We'll open that mode and get the motor spinning using MSP software controls.

1. Open MSP software.
2. Establish USB communication to your motor.
3. The "Tuning" dialog will appear. For now select the bottom option (run with no load) and hit "Next".

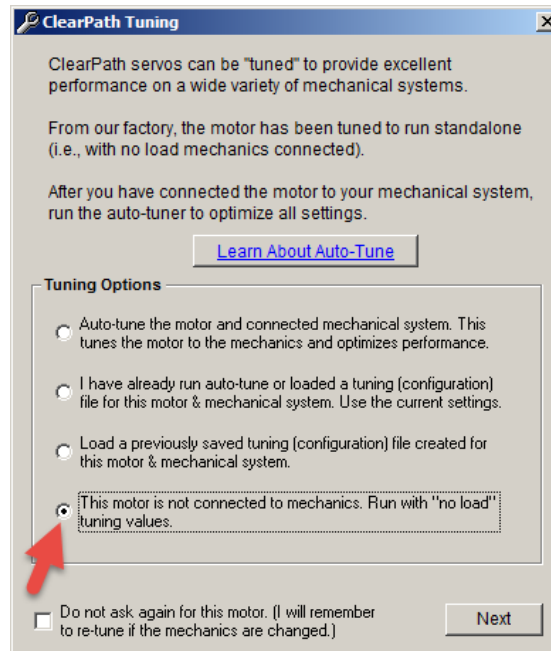

4. In MSP, Select *Mode>Step and Direction*. The mode controls window will open.
5. Set Units to RPM as shown in the figure below. This just tells MSP in what units to display distance, velocity, and acceleration.
6. Disable homing (see figure below).

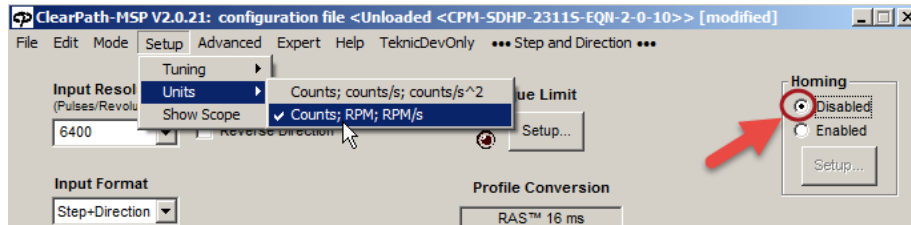

7. **Click the Override Inputs checkbox.** This turns on the software controls. You may notice that the other Soft Controls are no longer grayed out.

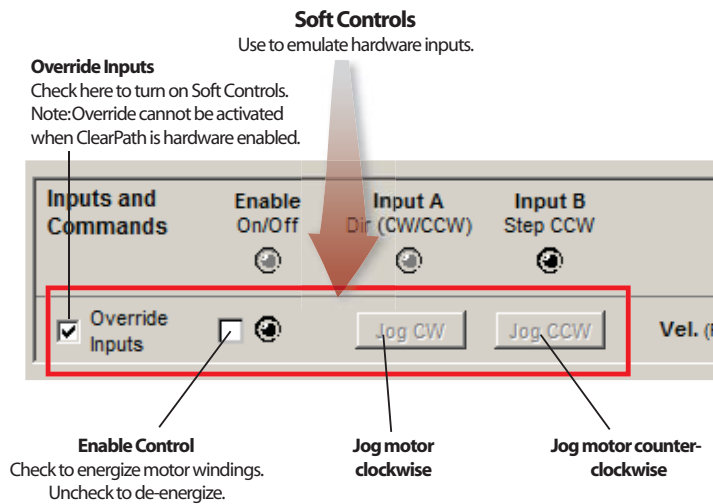

Check "Override Inputs" to turn on Soft Controls

8. **Safety check!** Before proceeding, make sure that the motor is securely clamped down and the shaft is safely positioned away from fingers, clothing, hair, cables, etc.

9. Check the Enable checkbox. **Caution: the motor is now energized and capable of motion.**

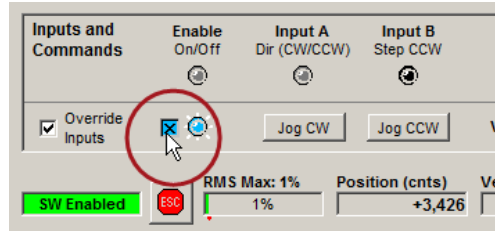

Enable using Soft Controls

10. **Make some moves.** With the motor enabled, click the jog CW/CCW (clockwise/counterclockwise) buttons. Change motor velocity and acceleration using the fields shown in the figure below.

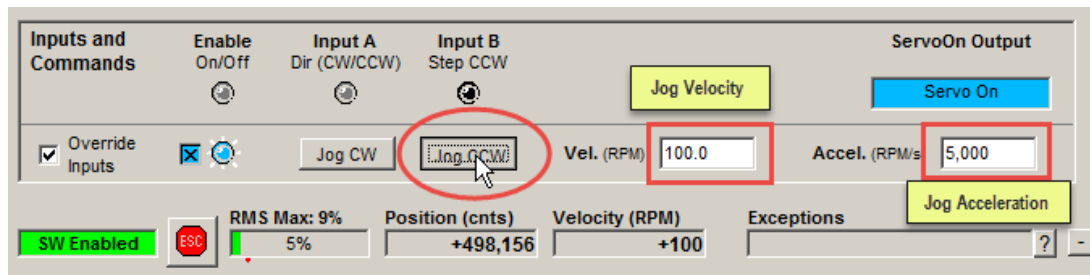

Click and hold jog buttons to spin your ClearPath-SD motor

DAMAGE WARNING: CLEARPATH INPUTS/OUTPUTS

Never connect “unprotected” inductive loads across your ClearPath motor’s input or output circuits. If you have inductive devices such as relay coils, solenoids, contactor coils, power-off brakes, (any device that works by intermittently powering and unpowering a large inductor/coil) connected across your ClearPath inputs or outputs, you will damage or destroy the ClearPath I/O circuits. Damage of this nature manifests as inputs or outputs not working, and can happen immediately or over time.

Always install a protection diode across any coil wired across your ClearPath inputs and output to prevent high voltage discharge spikes from permanently damaging the motor.

Please read the section [How Inductive Loads Can Damage ClearPath I/O](#) for more information on how to protect your ClearPath motor from this type of damage.

IF YOU EXPERIENCE A MOTOR SHUTDOWN OR WARNING

- If you see a small **triangular warning icon** (figure below) anywhere in the Mode Controls section, hover your cursor over the triangle to read the message (like a tool tip).

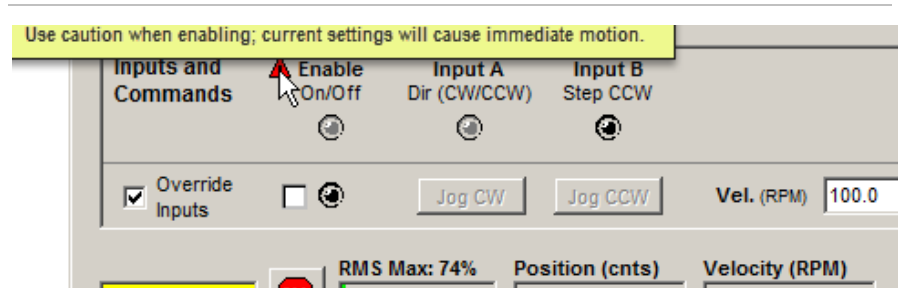

Hover cursor over "warning triangle" to read its message

- If you exceed your power supply's capability, ClearPath will tell you. You'll see warnings or shutdowns in the Exceptions field at lower right of the UI. (This does not mean that the motor is broken.) Try lowering the acceleration and/or velocity of your moves until the warning goes away.
- The majority of shutdowns are caused by weak power supplies, mechanical problems, and/or inappropriate settings. If your ClearPath experiences a shutdown, it is *reporting* a problem, but is not necessarily causing the problem.
- You can clear most shutdowns by toggling the Enable Input, but if you don't fix the underlying problem, you will probably continue to have shutdowns.
- IF THE STATUS LED FLASHES **RED**, your ClearPath motor has identified an internal hardware problem and needs to be returned for repair or replacement.

AUTO-TUNING

Tuning is required whenever you bolt your ClearPath motor to a new or different mechanical system. The Auto-Tune feature simplifies this formerly complicated and time consuming process.

BEFORE YOU BEGIN THE AUTO-TUNE PROCESS:

- Disable your motor.
- Recommended: Turn off your PC's sleep mode. If your PC goes into standby, sleep, or hibernation mode during Auto-Tune, the process will fail.
- Tighten all couplings, fasteners, pinions, and belts to the manufacturer's specifications.
- Make sure the axis or machine frame is fully intact.
- Don't try to tune a system on wheels or a flimsy table.
- Use a power supply designed for use with motor drives such as Teknic's IPC-3 or IPC-5 series, or use a beefy "bulk" linear power supply with at least 10,000 microfarads of capacitance.
- Don't use a weak switching power supply.

STARTING THE AUTO-TUNER

In MSP, click **Setup>Auto-tune**.

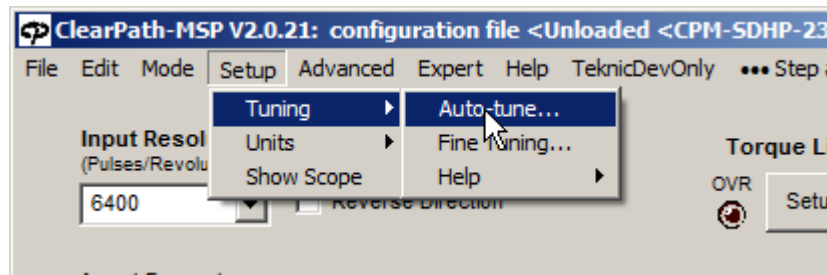

Start the Auto-Tuner

Important: The Auto-Tune application was carefully designed to walk users through the tuning process in a safe, step-by-step manner. Anyone engaged in Auto-Tuning must be able to read, understand, and follow all instructions presented.

DURING THE AUTO-TUNE PROCESS

- **Be careful.** Immobilize your motor with bolts or clamps. Keep your hands, hair and clothing away from the motor shaft and mechanical system.
- **Be patient.** Auto-Tune can take up to 30 minutes (5-15 minutes is more typical).
- **Be calm.** Expect to hear humming, buzzing, clicks and clacks. Loud squeals and buzzes are perfectly normal while ClearPath explores the limits of your mechanical system.

BEFORE YOU SEEK TECHNICAL HELP

Issue: The status LED on the motor is not lit, and my ClearPath apparently has no power.

- Connect power cable to ClearPath.
- Plug in and turn on power supply.
- Verify wall outlet is powered and no circuit breakers are tripped.
- If you accidentally reversed DC power to your ClearPath motor, it is very likely damaged and must be returned to Teknic.

Issue: The status LED is working, but my ClearPath and PC are not communicating.

- Disconnect the USB cable from ClearPath and your PC, close MSP, restart MSP, and reconnect the USB cable.
- Are you using a USB 3.0 port? Try a USB 2.0 port or a USB 2.0 hub plugged into a USB 3.0 port. ClearPath is compatible with *fully compliant* USB 3.0 ports, however there are known issues with the USB 3.0 ports made by certain manufacturers.

Issue: Auto-Tune failed to complete.

- Check to see if more than one version of MSP is installed on your computer. Always uninstall previous versions of MSP before installing new versions.
- If your power supply is a switcher or an underpowered “bulk” linear supply with insufficient current and/or capacitance, and cannot tolerate regenerated energy, you’ll have problems running Auto-Tune. ClearPath motors can operate between 24 and 75 VDC, but they require adequate power to Auto-Tune.

Issue: My ClearPath is getting shutdowns.

- A shutdown seldom means your ClearPath is broken or defective.
- Shutdowns with yellow or green blink codes usually mean that ClearPath is reporting a problem, but it is unlikely to be the problem. Connect ClearPath to your PC running MSP and look in the “Exceptions” field to see what’s being reported.
- Check the ClearPath User Manual (Appendix A) for blink code details, clues, and possible fixes.
- If you see a shutdown accompanied by a red flashing LED, you’ll probably have to return your ClearPath for repair or replacement. Check the Teknic website for repair/return information.

How do I restore my ClearPath to its factory default settings?

If you need to return ClearPath to its original state (i.e., configured exactly as it was when we shipped it to you), use File>Reset Config File To Factory Defaults. All parameters and settings will be over-written and ClearPath will be returned to its default factory configuration.

SAFETY WARNINGS

IMPORTANT: Read this manual before attempting to install, apply power to, or operate a ClearPath motor. Failure to understand and follow the safety information presented in this document could result in property damage, bodily injury or death.

PERSONAL SAFETY WARNINGS

- Do not wear loose clothing or unconfined long hair when using ClearPath motors. Remove ties, rings, watches and other jewelry before operating an unguarded motor.
- Do not operate a ClearPath motor if your alertness, cognitive function, or motor skills are impaired.
- Always handle, and carry a ClearPath motor by the housing (don't carry it by the shaft or cables).
- Be aware that in certain modes of operation ClearPath is designed to spin as soon as DC bus power is applied.
- Always understand how to use a mode of operation and its associated controls before attempting to operate a ClearPath motor.
- Install and test all emergency stop devices and controls before using ClearPath.
- Before applying DC power, secure the ClearPath motor to a stable, solid work surface and install a finger-safe guard or barrier between the user and the motor shaft.
- Provide appropriate space around the ClearPath motor for ventilation and cable clearances.
- Do not allow cables or other loose items to drape over, or rest near the ClearPath motor shaft.
- Never place fingers, hands, or other body parts on or near a powered ClearPath motor.
- Thoroughly test all ClearPath applications at low speed to ensure the motor, controls, and safety equipment operate as expected.

CE COMPLIANCE WARNINGS

- Do not open device enclosure. There are no user serviceable parts inside this product.
- Follow all instructions and use the product only as directed.
- Safety of any system incorporating this equipment is the responsibility of the system designers and builders.
- The machine designers need to recognize and incorporate required warning symbols, guards and shields for ClearPath motors that are used in applications that can result in the

external accessible parts of their machine exceeding a temperature of 65 Celsius. This is required as a method to reduce burns. A tool shall be required to remove any guards and/or shields.

- ClearPath motors require that a path exist between the motor chassis and the Protective Earth (PE) connection of the machine to which it is affixed. (Note: The PE connection is often satisfied by simply bolting the motor to the machine; however it is the users responsibility to verify the PE connection.) If an external grounding wire is required, use the same or larger wire gauge as used between the DC power supply and ClearPath Motor.
- Any maintenance or repair guide created by the user shall state that power shall be removed before the Protective Earth ground conductor is disconnected. When reconnecting power, the Protective Earth ground conductor shall be the first wire reconnected. Main power may be reconnected only after the Safety Ground connection is secure.
- When the ClearPath motor is mounted in an application where the shaft end is higher than the electrical connection end of the motor, the USB connector plug provided by Teknic must be installed. The USB plug in these installations becomes an element to prevent the spread of fire per EN 61010-1 section 9.3.2 part c.

GENERAL DISCLAIMER

The User is responsible for determining the suitability of products for their different applications. The User must ensure that Teknic's products are installed and utilized in accordance with all local, state, federal and private governing bodies and meet all applicable health and safety standards.

Teknic has made all reasonable efforts to accurately present the information in the published documentation and shall not be responsible for any incorrect information which may result from oversights. Due to continuous product improvements, the product specifications as stated in the documentation are subject to change at any time and without notice. The User is responsible for consulting a representative of Teknic for detailed information and to determine any changes of information in the published documentation.

If Teknic's products are used in an application that is safety critical, the User must provide appropriate safety testing of the products, adequate safety devices, guarding, warning notices and machine-specific training to protect the operator from injury.

INTRODUCTION

WHAT IS A CLEARPATH MOTOR?

ClearPath is an all-in-one servo system: a precision brushless servo motor (with encoder) combined with a powerful integrated servo drive, trajectory generator, and internal controller, in a package about the size of a servo motor alone. ClearPath brings affordable, user-friendly, precision motion control to everyone from the OEM machine builder and shop automation specialist, to the educator, artist, and maker.

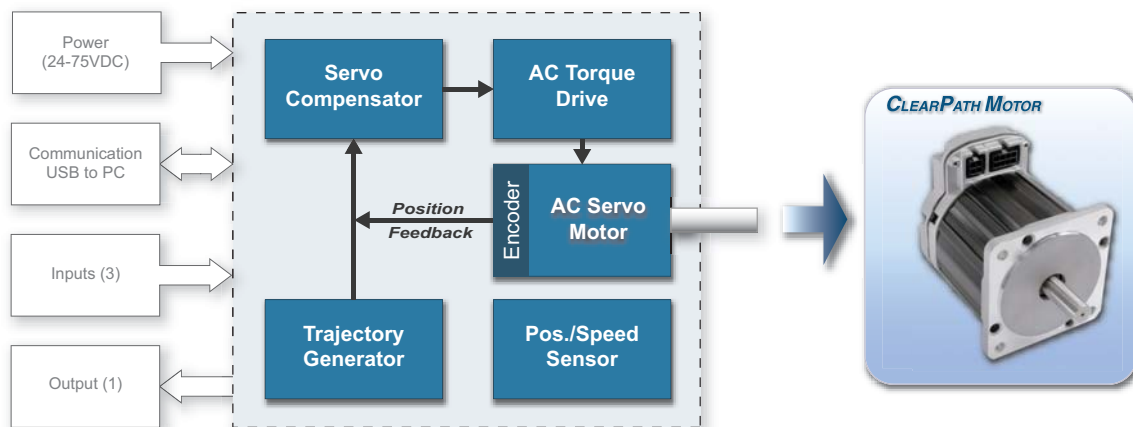

ClearPath functional blocks

ClearPath is a professional level, industrial grade product. The motor subsystem is based on Teknic's [Hudson family](#) of brushless servo motors, with similar instrument grade bearings, stainless steel shaft, windings, rare earth magnets, and encoder technology. The servo drive electronics and motion control firmware employ the same state-of-the-art technology and advanced motion control algorithms as our high-end, non-integrated servo control products.

ClearPath Simplicity begins with a quick, uncomplicated setup. Install the included MSP software, connect ClearPath to your PC via USB, and configure and tune your ClearPath. Once setup is complete, disconnect ClearPath from your PC and start moving. With just three inputs and one output, sending commands and receiving feedback is simple and intuitive.

ClearPath MSP software is written in plain English with plenty of tips and annotations. Use MSP to select a mode of operation, set your move parameters and options (distance, speed, acceleration, torque) and tune the system. There's no steep learning curve with ClearPath.

Flexibility is evident in the many operating modes available. ClearPath motors can do:

- Point-to-Point Positioning (move and settle with precision).
- Velocity Modes (spin at constant rotational speeds).
- Torque Modes (precisely control torque at the shaft).
- Stepper Emulation (use standard step-and-direction signals).

ClearPath motors are at home in applications ranging from variable speed conveyors to multi-axis positioning robots, to kinetic sculptures. And, while most ClearPath customers have a specific application in mind, it's reassuring to know that your ClearPath can be reprogrammed to perform a different job in just a few minutes.

Safety and self-protection features are standard. ClearPath will rapidly shut down if it becomes overloaded, overheated, detects a hard stop, or exceeds any of the safety or motion limits you specify.

Made in USA. Each ClearPath motor is built and tested in our New York manufacturing facility, so you can be certain you're getting a high quality, fully tested motion control product right out of the box. Additionally, Teknic backs up each ClearPath motor with a generous three year warranty.

PARTS OF A CLEARPATH MOTOR

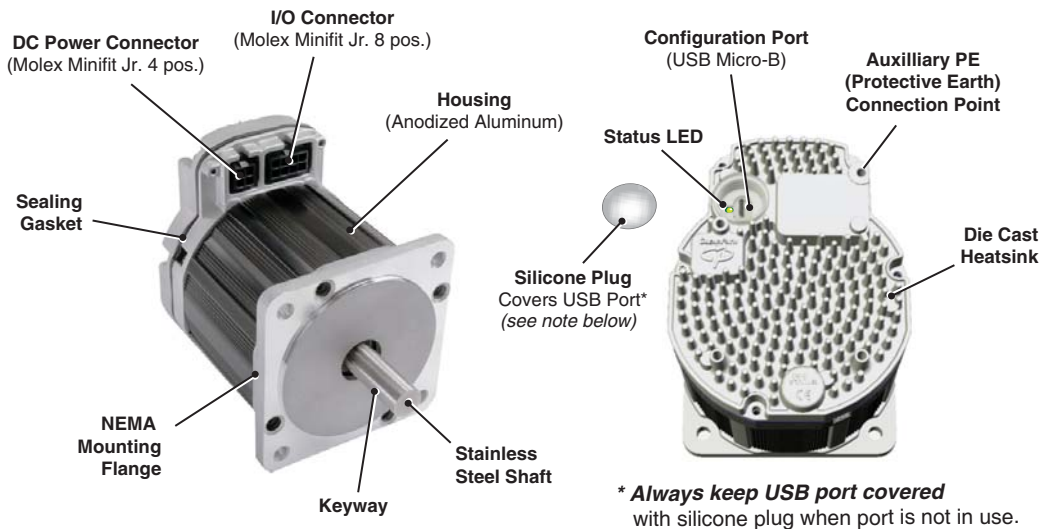

ClearPath Motor

DC Power Connector - Apply main DC power (24-75VDC) to this 4-position Molex MiniFit Jr. connector.

I/O Connector - Access ClearPath's three inputs and one output through this 8-position Molex MiniFit Jr. connector.

Configuration Port - Use this port to connect ClearPath to a Windows PC with a standard USB (Type A to Micro-B) cable. Cover port with included silicone plug when not in use.

Status LED - Tri-color LED Indicates operational status of ClearPath device. See Appendix A for LED codes.

Auxiliary PE (Protective Earth) Connection Point - Typically used only if the motor mounting bracket or plate is not bonded to the machine's PE terminal. See Appendix E: Grounding and Shielding for complete details. To use, connect a wire between this screw boss and your machine chassis to ensure a good connection to the machine's Protective Earth terminal.

EXAMPLE APPLICATION: ABSOLUTE POSITIONING MODE

Read this section for a brief introduction to ClearPath technology and terminology through an example application. Please visit <https://www.teknic.com/watch-video/> to view ClearPath application videos.

SUMMARY OF OPERATION

Note: This section describes only one example application in one mode of operation. Absolute Positioning (4-position) mode allows you to define up to four target positions and command moves between any of them simply by changing the logical states of the ClearPath inputs.

In the figure below, a ClearPath model MCPV is coupled to a ball screw positioning stage. For now, we'll say that ClearPath has already been configured and programmed via the included MSP software. This just means that the mode of operation, target positions, velocity, acceleration, and options are already stored in ClearPath memory and the motor is tuned and ready to go. ClearPath configuration and setup will be discussed later in this section.

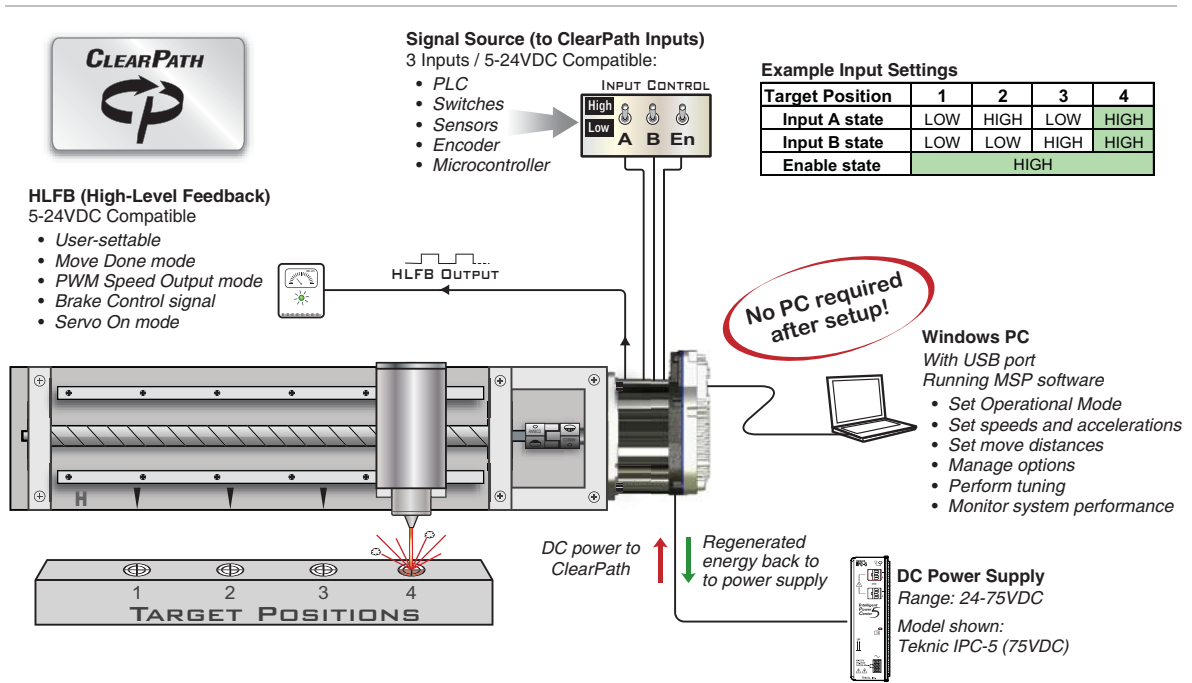

ClearPath Absolute Positioning (4-Position) Mode

Getting started. To energize the motor, simply apply a DC voltage to the Enable input. Once enabled, the motor is considered “live”, i.e. the motor is energized and will execute moves in response to state changes at Inputs A and B.

Caution: Depending on the exact mode and settings selected, ClearPath may automatically move upon enable *with no user changes to the inputs.*

In this particular mode, ClearPath must perform a homing operation (all of the target positions are defined in terms of distance from the "home" reference position). Setting up your homing parameters is easy, and only has to be done once (using the included MSP software).

After homing is complete, ClearPath can be commanded to move to any of the four target positions by changing the state of Inputs A and B.

EXAMPLE: MAKING A MOVE

Motion objective: Move the load platform from position #1 to position #4.

User action: Simultaneously set Inputs A and B high. This can be done with toggle switches, PLC, microcontroller, or other compatible device.

Motion result: The motor immediately begins a move based on the user's acceleration and velocity settings. The motor then decelerates and settles at position #4. Note: ClearPath will actively servo to maintain position until another move command is received, unless the system is intentionally disabled, powered down, or in a shutdown state.

The Digital Output (we call it HLFB, for High-Level Feedback) can be configured to signal when ClearPath completes a move, reaches a specified speed or torque, or shuts itself down for safety reasons. See the section on Outputs (High-Level Feedback) for more on HLFB modes.

OVERVIEW: CONFIGURING A CLEARPATH

ClearPath must be configured and tuned before it can be used in a motion application. The main configuration steps are outlined below. Each of these points is discussed in greater detail later.

1. Install ClearPath software (MSP) on a qualified Windows PC.
2. Connect your I/O devices to ClearPath (switches, PLC, microcontroller, etc.).
3. Supply DC power (24-75VDC) to ClearPath.
4. Connect ClearPath to your PC with a standard USB cable.
5. Use ClearPath MSP software to:
 - a. Select a mode of operation.
 - b. Set motion parameters and options (acceleration, velocity, torque, safety settings, etc.).
 - c. Tune the motor to the mechanical system.
6. Test and adjust settings as needed to optimize quality of motion and overall system performance.
7. Disconnect the computer. Cover USB port with the included silicone plug, and run your application. No computer is needed once setup is complete.

Save your settings! You can save your ClearPath settings to a motor configuration file—the file extension is .mtr—at any time. This allows you to easily test and compare various sets of tuning parameters. And, if you build many machines of the same design, you'll appreciate how quickly you can load a saved configuration file into a new ClearPath.

OVERVIEW: CLEARPATH I/O

ClearPath I/O provides a flexible high-level control interface for your ClearPath motor. There are no proprietary connectors, cables or sensors, so you decide which input devices are right for your ClearPath application.

Once the inputs are wired up, you'll be able to execute moves either by 1) changing the logical (on/off) state of the inputs or 2) by applying a pulse or PWM signal to the appropriate input. See the chapter on *Inputs and Outputs* for I/O wiring information.

Note: ClearPath inputs automatically change function based on mode of operation selected. See the Operation Mode section for input function.

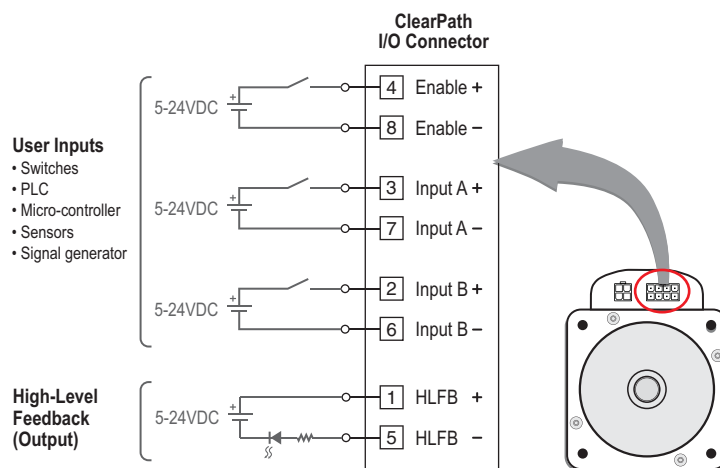

Simplified overview of ClearPath inputs and output

Enable Input. Asserting the Enable input (logical 1, high, 5–24VDC) energizes the motor coils. Deasserting Enable (logical 0, low state, 0 volts) removes power from the motor coils.

Inputs A and B. Once enabled, ClearPath can respond to the state of Inputs A and B. ClearPath supports a wide range of input devices, from simple toggle switches to sensors, relays, PLC outputs, microcontroller outputs, and more can be wired to a ClearPath.

High-Level Feedback (HLFB). ClearPath's HLFB output can be set up to alert the user or control system to one of several conditions. HLFB can be configured to:

- Change state if a Shutdown occurs.
- Signal when ClearPath is running at your commanded velocity or torque.
- Signal the end of a move (based on user-defined settling requirements).
- Output a PWM signal whose duty cycle is proportional to motor speed, or torque.

POWERING A CLEARPATH SYSTEM

SELECTING A DC BUS POWER SUPPLY

ClearPath motors can be powered from 24–75VDC power supplies; however the actual minimum voltage and current required to power a ClearPath in a given application is highly dependent on the application requirements (i.e. how much torque and speed is required) as well as motor winding and magnet configuration.

Teknic power supplies have been extensively tested and widely used in ClearPath applications, but third-party (non-Teknic) power supplies can be used as well. See next page for Teknic power supply overview. Please visit the Teknic website for power supply features, specifications, and pricing.

CLEARPATH OPERATING VOLTAGE

RECOMMENDED OPERATING VOLTAGE: 24–75VDC

Note: Always operate ClearPath within the recommended operating voltage range (24VDC to 75VDC). If measuring the *actual bus voltage reaching your ClearPath motor*, probe directly on the ClearPath power connector.

The ideal ClearPath power supply...

...is capable of delivering high peak current and handling back-EMF (reverse voltage generated by the spinning motor that "cancels" a portion of the incoming supply voltage). A power supply specifically designed for motor drive power—like Teknic's "Intelligent Power Center" supplies (IPC-3 and IPC-5)—will have these features, and are ideal for servo systems like ClearPath. "Bulk" linear power supplies—basically a transformer, rectifier, and large capacitor—can also work adequately. Normal switching-mode power supplies are not generally the best choice.

Important: Thoroughly test your ClearPath application with the intended power supply *under worst case, full load conditions* to ensure sufficient power capacity and adequate operating margin.

Why you should avoid (most) switching power supplies

Switching power supplies are typically not well suited to high power servo applications because they generally have the same peak *and* continuous-current ratings. This can lead the user to purchase a large but ultimately under-worked power supply just to meet peak current requirements.

In addition, most switchers are not designed to handle the regenerated energy (back-EMF) that a decelerating motor returns to the power supply. Without special provisions, regenerated energy can cause a switching supply to reset, power cycle, shut down, or even fail.

NOTES ON "LOWER VOLTAGE" BUS POWER SUPPLIES

ClearPath motors can and do work with power supplies as low as 24 volts DC, provided that the power supply has sufficient voltage, current, and capacitance to meet your application's motor torque and speed requirements. This assumes that the motor has been properly sized for the application.

IMPORTANT: An underpowered supply can result in ClearPath performance limitations and problems including the following:

- **ClearPath is unable to complete the auto-tuning process.** The ClearPath auto-tuning feature uses aggressive moves to test the limits of each mechanical system. A weak power supply (i.e. one that can't handle the peak current demands required by ClearPath) may "droop" the supply below ClearPath's minimum operating voltage, about 21.5VDC. This can cause loss of communication and/or a safety shutdown. Needless to say, if Auto-Tune cannot run to completion, you probably have an underpowered supply.
- **ClearPath completes the auto-tuning process but experiences certain warnings or shutdowns during programmed motion.** If Auto-Tune runs to completion, but you experience torque saturation, voltage saturation, or both during regular machine operation, you may be exceeding the supply's voltage and/or current capability.

If you have an underpowered DC bus supply

If you suspect your power supply is underpowered, one of these solutions may work for you:

- **Lower the commanded acceleration and/or velocity.** Sometimes lowering commanded acceleration and/or velocity can reduce the burden on a weaker power supply enough to eliminate shutdowns caused by "power starvation".
- **Upgrade to a more powerful supply.** Look for a supply with higher voltage, higher peak and continuous current ratings, and a large capacitor bank.
- **Modify your existing power supply.** In some cases adding a large capacitor and a few inexpensive components to an underpowered supply can boost the supply's output satisfactorily. Note: Consult your power supply manufacturer before making any modifications to a commercial product.

TEKNIC POWER SUPPLIES

Teknic manufactures two 75VDC power supplies designed specifically for powering motor drives—the IPC-3 and IPC-5. These supplies effectively manage peak current demand, regenerated energy, and include several built-in protective features. They are ideal for use with ClearPath motors.



Teknic IPC-3



Teknic IPC-5

Teknic 75VDC IPC family power supplies

TEKNIC MODEL IPC-3

The IPC-3 open-frame power supply can typically power one to four ClearPath motors. The actual number depends on the application—fewer when the motors are generating high torque continuously at high speeds, and more when the motors are intermittently using bursts of power like in many point-to-point positioning systems. Please visit Teknic's website (www.teknic.com) for more information, features, and specifications.

TEKNIC MODEL IPC-5

The IPC-5 fully enclosed power supply can typically power two to six ClearPath motors. The actual number depends on the application—fewer when the motors are generating high torque continuously at high speeds, and more when the motors are intermittently using bursts of power like in many point-to-point positioning systems. Please visit Teknic's website (www.teknic.com) for more information, features, and specifications.

BEFORE POWERING A CLEARPATH

- Check for proper DC power polarity before connecting power to a ClearPath. Reversing DC power polarity may damage the unit and void the warranty.
- Verify that the power supply is turned off and discharged before connecting to a ClearPath. Connecting and disconnecting the motor from a charged power supply will cause electrical arcing that can damage the connector pins over time.
- Never connect a ClearPath motor directly to an AC outlet. This will damage the ClearPath motor and void the warranty.

- It is acceptable to daisy chain power to several ClearPath motors provided that the combined current draw of the motors does not exceed 10A during operation. If total combined current draw is expected to exceed 10A, star power wiring should be used.
- When a ClearPath motor is powered on, a startup routine energizes the motor for a few milliseconds. During this startup routine it is not uncommon for a small amount of motion to occur (1° typical).

POWER SUPPLY SWITCHING AND FUSING

POWER SUPPLY CONTROL SWITCH

The power supply for a ClearPath should not be switched on and off from the DC output side. Switching the DC output side, especially with inexpensive relays, will ultimately result in poor performance (drop outs) due to pitting, corrosion and contact welding. If a power switch is required, install it such that the supply is disconnected from the AC input side (see figure below).

POWER SUPPLY FUSING

If you require an external fuse on your power supply's DC output (to meet compliance standards for example) it should be installed in line with the positive leg of the DC output wiring as shown below. Use a maximum 10A time delay fuse. Note: Teknic IPC power supplies are not internally fused on the DC output side.

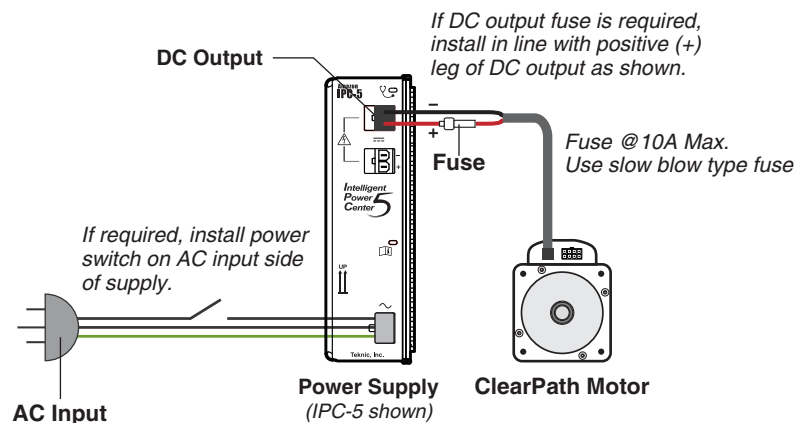

Power supply switching and fusing detail

BASIC POWER CONNECTION (2 MOTORS)

One or two motors can be connected directly to the IPC-3 or IPC-5 power supply as shown below. To connect more than two motors, consider chaining power or using the optional POWER4-HUB board.

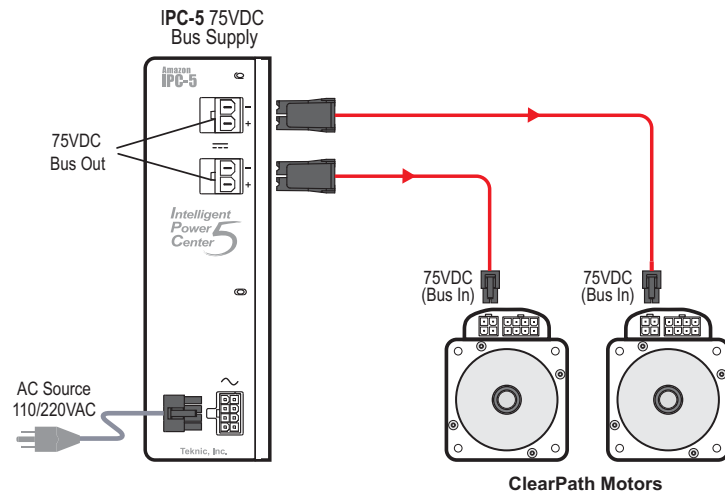

Direct Connection

POWER CHAINING (MULTIPLE MOTORS)

For applications with several ClearPath motors, chaining power from motor to motor may be preferable. You will have to fabricate power cables as shown below to chain power from motor to motor.

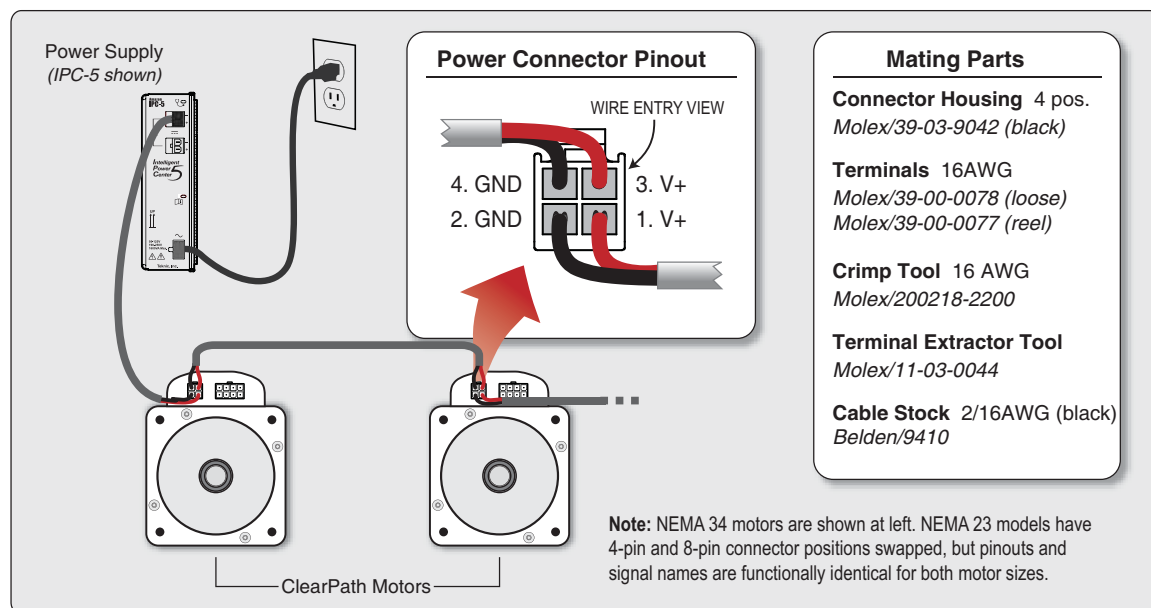

Power Chaining ClearPath motors. See [Appendix C](#) for full connector information.

USING A POWER4-HUB

The POWER4-HUB (Teknic PN **POWER4-HUB**) is an optional ClearPath accessory board that:

1. Distributes DC bus power to as many as four ClearPath motors per POWER4-HUB, thus eliminating the need for special "power chaining" cables.
2. Delivers low voltage **logic power backup** to your ClearPath motors. Logic power backup keeps the motors' electronics "alive" even if DC bus power is dropped. This translates to uninterrupted communication, continuous status monitoring, and retention of encoder position.

Note: You will be unable to spin your motors when using only logic power backup. Logic power backup will keep the motor electronics alive, but is not designed to run motors.

POWER4-HUB OVERVIEW DIAGRAM

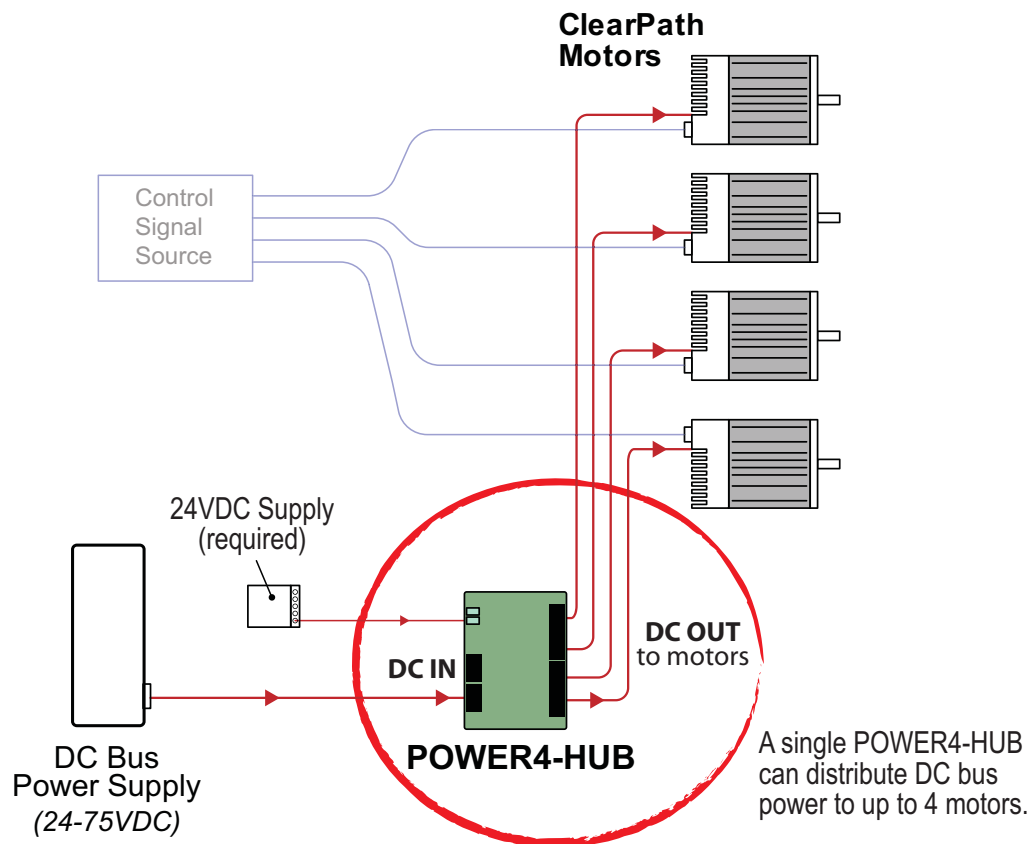

POWER4-HUB in a ClearPath system

POWER4-HUB: THINGS TO KNOW

- **Logic backup power is not designed to spin motors.** It is designed to maintain uninterrupted, low voltage power to the motor electronics (encoder, DSP, communication, I/O, and associated circuits).
- **Damage Warning: Reversing DC bus power polarity to the POWER4-HUB will permanently damage it.** Use a meter to verify correct DC bus power polarity before connecting the power supply to the POWER4-HUB.
- **Do not "hot swap" DC power connectors.** Turn off DC bus power supply before connecting a motor to the POWER4-HUB. *Connecting and disconnecting the motor from a live power supply will cause electrical arcing that will damage the connectors over time.*
- **Logic backup power should not be used as a means of switching DC bus power on and off.** To control DC bus power, use a contactor on the AC side of the DC bus power supply.
- **Do not connect more than two POWER4-HUBs to a power supply.** Continuous and peak current usage must not exceed the power supply's specifications.

It is the user's responsibility to ensure that the DC bus power supply has sufficient continuous and peak power to meet their application requirements.

- **Do not attempt to power more than four ClearPath motors from a single POWER4-HUB.**

POWER4-HUB: COMPLIANCE NOTES

- Any 3rd party (non-Teknic) power supply used with the POWER4-HUB, should be current limited or fused to 25A or less using 25A, 300VDC (UL Listed) fuses.
- If UL compliance is a consideration, select a DC, UL Listed fuse.
- For those seeking a Class G fuse, the **SC-25 from Eaton Cooper Bussmann**, or **OSLCO25 from Littelfuse** is recommended. Fuse holders (also rated this way) include the **HPS-FF and TCFH30N (from ECB/Littelfuse respectively)**.

PARTS OF A POWER4-HUB

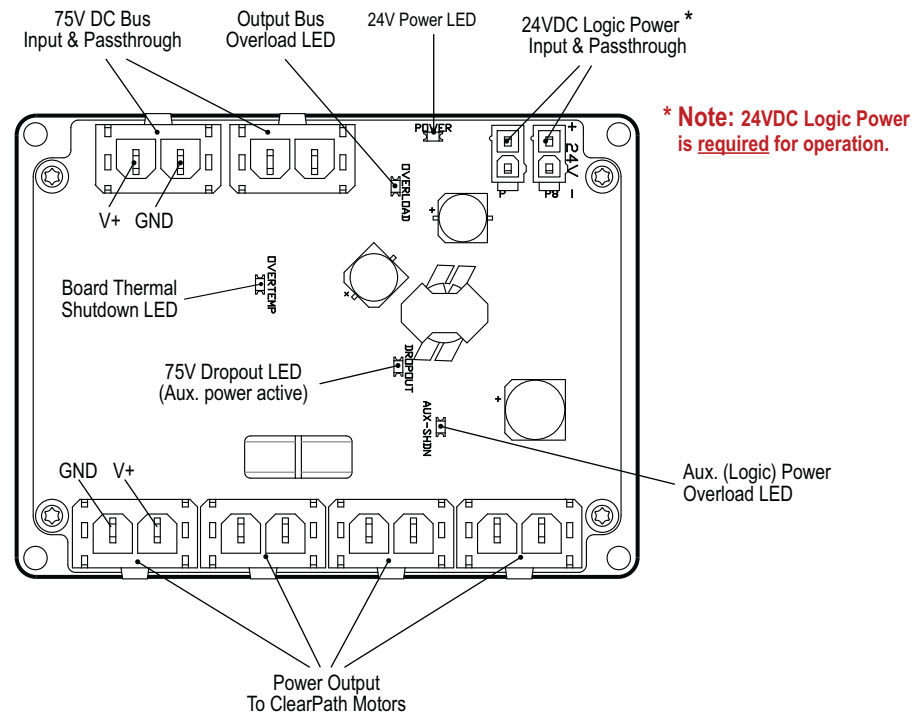

Parts of a POWER4-HUB

DC Bus Power Input/Passthrough (Qty. 2) - Supply 24-75VDC power from your DC Bus Supply to either of these connectors (they are wired in parallel). The other connector can be used to daisy chain bus power to a second POWER4-HUB if desired, or left unconnected.

IMPORTANT: Never connect two IPC-3/-5 power supplies to a single POWER4-HUB. These power supplies are not designed to operate in parallel or series configurations.

DC Bus Power Outputs (Qty. 4) - These four connectors supply bus power to your ClearPath motors. In addition, if power is dropped, they carry aux. power to keep maintain motor communication to the host application. They are fully short-circuit protected.

24VDC Logic Power Input, with Passthrough (Qty. 2) - Supply low power 24VDC logic power to either of these connectors (they are wired in parallel). The other connector can be used to daisy chain power to a second POWER4-HUB.

POWER4-HUB LEDs - There are 5 LED indicators on a POWER4-HUB. Please refer to the section "POWER4-HUB LEDs" (later this section) for a complete explanation of what the POWER4-HUB LEDs indicate.

CONNECTIONS FOR A SINGLE POWER4-HUB SYSTEM

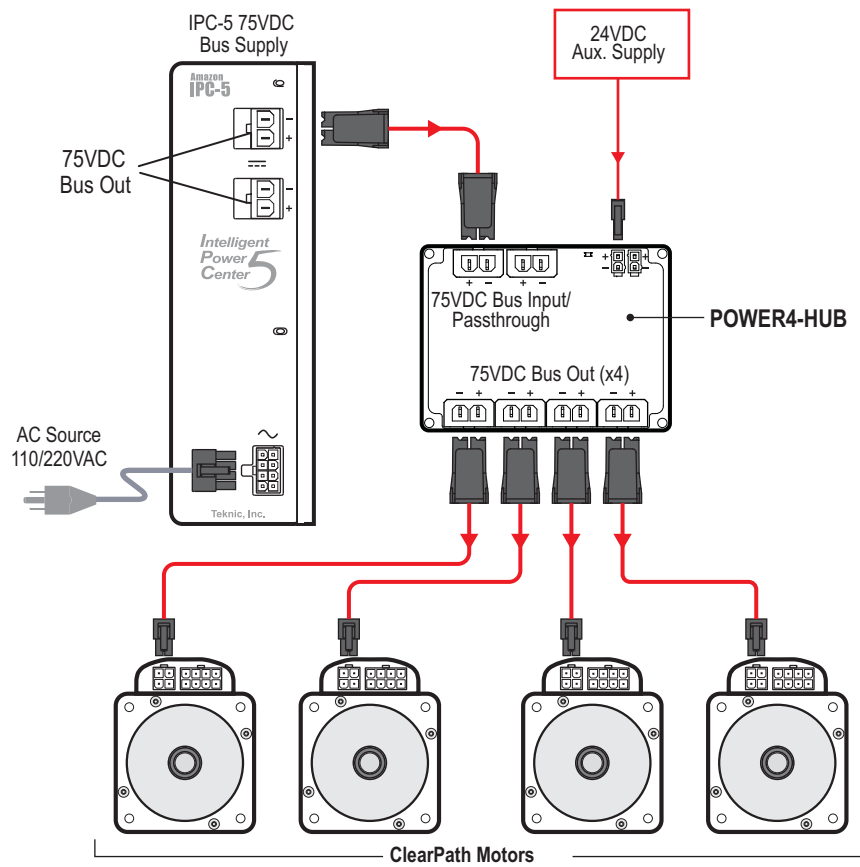

Single POWER4-HUB System

CONNECTIONS FOR A DUAL POWER4-HUB SYSTEM

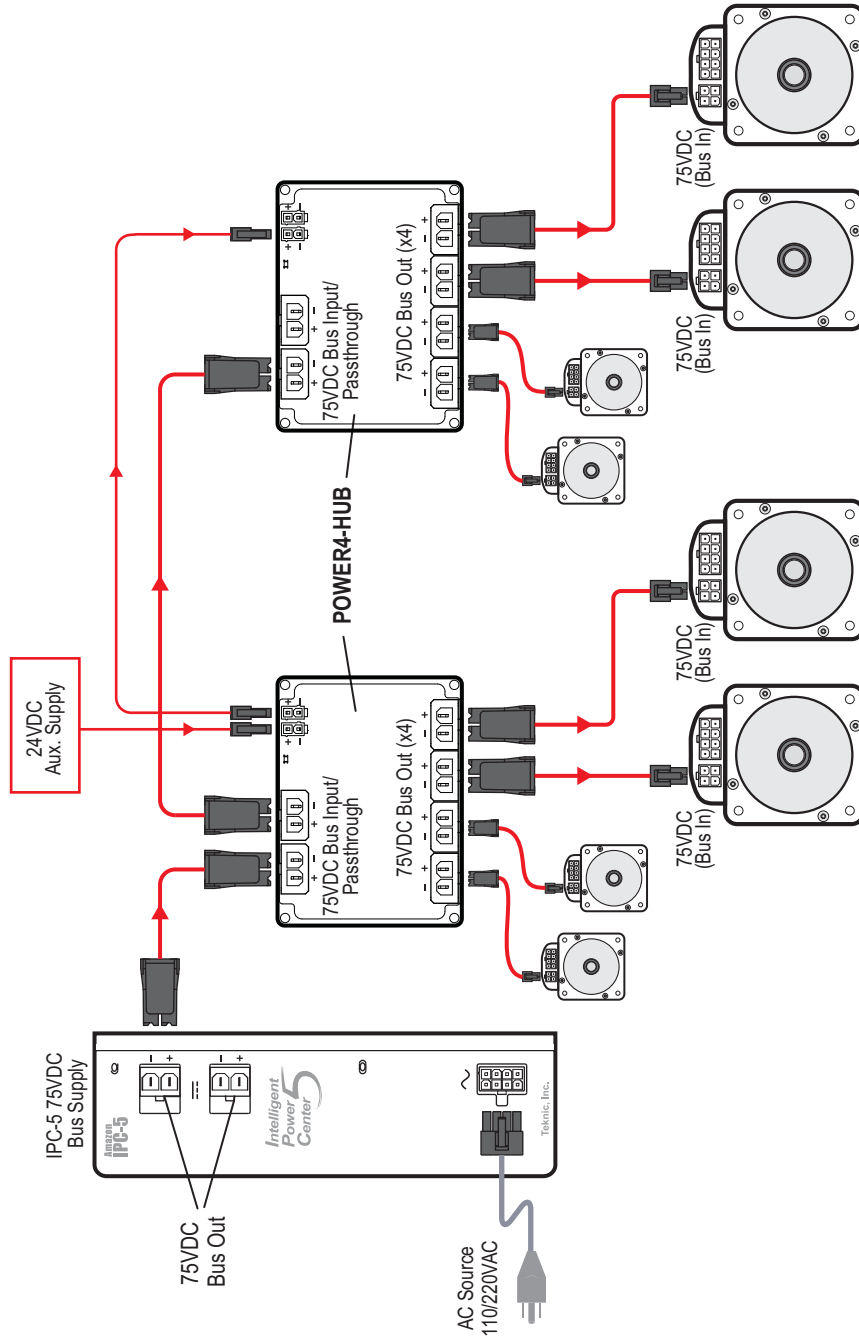

Two POWER4-HUBs powering 8 ClearPath motors

AUXILIARY (24V) LOGIC POWER SUPPLY

The POWER4-HUB requires 24VDC to function. This is labeled as "24VDC Aux. Supply" above. See appendix " Logic Power Supply Sizing" for power budgeting information. Note: Never use the main DC bus power supply (even if it is 24VDC) for this purpose.

POWER4-HUB LED CODES

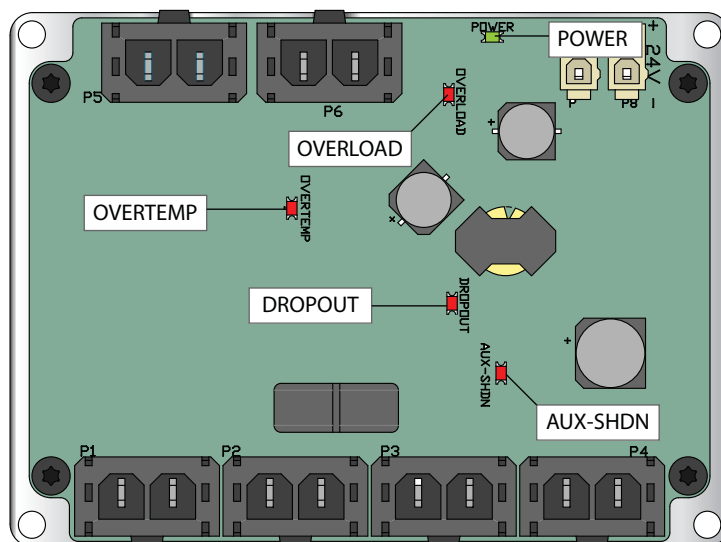

POWER4-HUB LEDs

LED Name	Color	<u>LED On</u> Indicates	<u>LED Off</u> Indicates
POWER <i>24V Power</i>	Green	Normal operation. Aux. 24V supply voltage detected.	Aux. 24V supply voltage not detected. Hub not functional.
OVERLOAD <i>Output Bus Overload</i>	Red	Short (or near short) circuit at bus output. POWER4-HUB electronically disconnects bus input from bus output in this case as a protective measure.	Normal operation.
OVERTEMP <i>Board Thermal Shutdown</i>	Red	Board temperature has exceeded 105°C. (Note: After an overtemp event, LED will turn off when board temp falls below 95°C.)	Normal operation. (Board temp is < 105°C.)
DROPOUT <i>75V Dropout LED</i>	Red	Bus supply has "dropped out", meaning the DC Bus has fallen below 18.2 VDC. Aux. power is active.	Normal operation.
AUX-SHDN <i>Aux. Power Overload</i>	Red	Motor bus has dropped out and aux. supply is in an overloaded state. (The motor load has exceeded 1000mA for >20mS.) This is a latching shutdown. You must cycle the aux. power supply to clear.	Normal Operation

INPUTS AND OUTPUTS

ClearPath inputs and output (I/O) allow the user to send and receive control signals from a ClearPath motor. There are a total of three digital inputs and one digital output accessible through the 8-position Molex MiniFit Jr. connector. Refer to the diagram below for a list of I/O connector mating parts.

DAMAGE WARNING: Never connect unprotected inductive loads (things like relay coils, solenoids, contactor coils, etc.) such that they can discharge across ClearPath Inputs or outputs. Doing so will irreversibly damage the ClearPath motor inputs/outputs. See the section [How Inductive Loads Can Damage ClearPath I/O](#) for more.

I/O CONNECTOR PARTS AND PINOUT

Clearpath I/O Features

- ✓ 5-24VDC compatible
- ✓ Digitally filtered
- ✓ Optically isolated
- ✓ Configurable output
- ✓ Many input options

I/O Connector Pinout

Mating Parts

Connector Housing 8 position
Molex/39-03-9082 (black)

Terminals 22-28 AWG
Molex/39-00-0047 (loose)
Molex/39-00-0046 (reel)

Crimp Tool 22-28 AWG
Molex/63819-1000

Terminal Extractor Tool
Molex/11-03-0044

Cable Stock 8/22 AWG
Belden 9421

Note: NEMA 34 motor shown at left. NEMA 23 models have 4-pin and 8-pin connector positions swapped, but pinouts and signal names are functionally identical for both motor sizes.

Pin	Color	Name
1	GRN	HLFB +
2	BLK	Input B +
3	WHT	Input A +
4	BLU	Enable +
5	RED	HLFB -
6	YEL	Input B -
7	BRN	Input A -
8	ORN	Enable -

ClearPath I/O connector and mating parts

CLEARPATH INPUTS

Damage Warning: Protect Your Inputs and Outputs

To prevent motor I/O damage, never connect unprotected inductive loads (things like relay coils, solenoids, contactor coils, brake coils, etc.) such that they can discharge across ClearPath inputs or outputs. Doing so will blow out the ClearPath motor I/O circuits, causing permanent damage to the motor. See the section [How Inductive Loads Can Damage ClearPath I/O](#) for more information on preventing this kind of damage.

The three inputs, designated *Enable*, *Input A*, and *Input B*, are designed for use with 5-24VDC logic levels and pulses from a wide variety of signal sources and devices including PLCs, microcontrollers, and even mechanical switches.

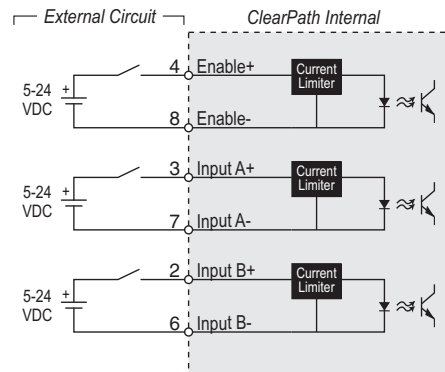

ClearPath Inputs shown with simple switches

INPUT CURRENT DRAW

See table and graph for minimum input current required for ClearPath input circuits over the range of acceptable input voltages.

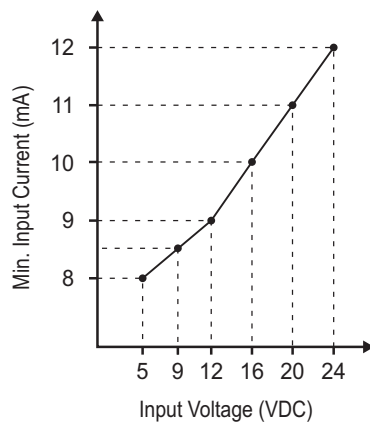

Voltage at ClearPath Input	Minimum Input Current Required*
5 VDC	8 mA
12 VDC	9 mA
24 VDC	12 mA

*To guarantee reliable input operation, the supply used with your ClearPath inputs should be capable of sourcing *at least* the above stated current at the associated voltage for each input used.

Minimum input current for given input voltages

HOW INDUCTIVE LOADS CAN DAMAGE CLEARPATH I/O

Your ClearPath input and output circuits can be damaged if exposed to high voltage, inductive kickback. Inductive kickback is manifested as the short term, high voltage spikes produced by coil-actuated (inductive) devices when power is removed from the coil. Such devices include contactor coils, mechanical relay coils, solenoids, and power-off brakes.

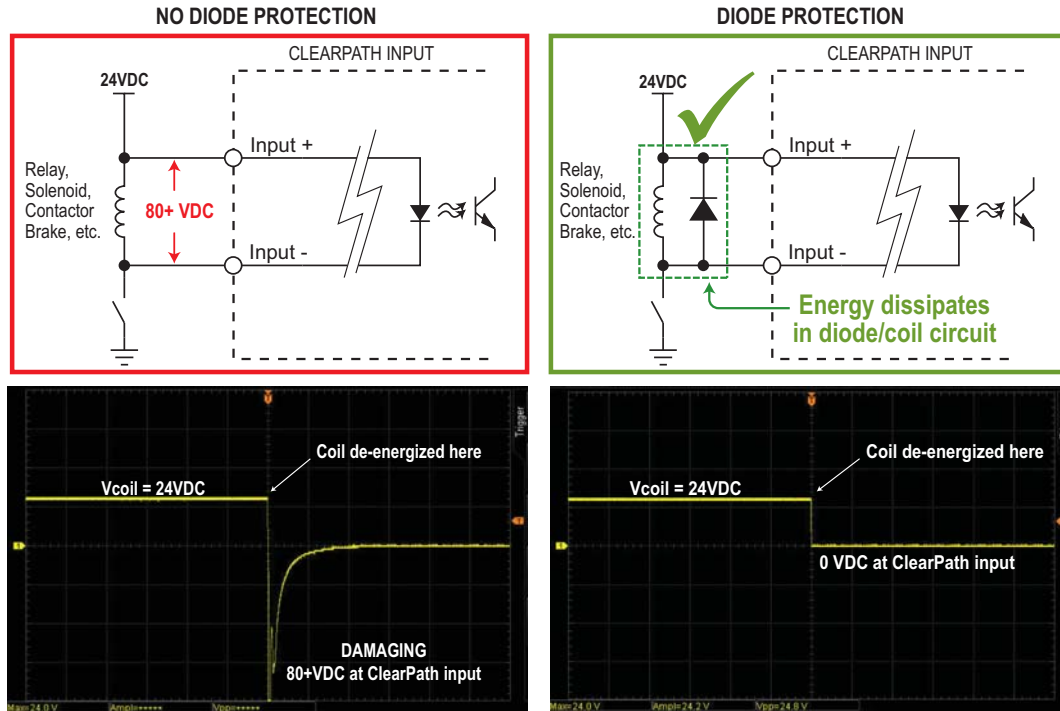

Use a flyback diode (right) to protect ClearPath inputs and outputs.

Without a “safe” discharge path, such as provided by a flyback diode, when the coil from an inductive device is de-energized it can produce a very high voltage spike that will damage ClearPath inputs connected in parallel with the coil. These voltage spikes can peak in the hundreds of volts for tens of milliseconds. And, while ClearPath I/O circuits are very robust, they are not designed to manage hundreds of volts above their operating range of 4-28VDC.

HOW TO PROTECT YOUR MOTOR FROM INDUCTIVE KICKBACK

- 1) Avoid connecting inductive loads (coils) such that they can discharge across your ClearPath inputs or output. Use a separate power supply for inductive devices to isolate them from low voltage digital devices.
- 2) If you must connect a coil-actuated device across your ClearPath I/O, **add a protection diode in parallel with the coil in the polarity shown above.** FYI: Protection diodes are referred to by various names including flyback diode, snubber diode, or catch diode. We recommend using a common **1N4004** diode for most applications.

THE ENABLE INPUT

The **Enable Input** controls power to the motor coils. When a ClearPath is powered up and the Enable Input is asserted (i.e. 5–24VDC is present at the Enable Input) the motor windings energize and ClearPath is able to respond to control signals at Inputs A and B.

When Enable is deasserted power to the motor coils is removed and the motor cannot respond to user inputs².

Safety Note: The Enable Input is not designed for safety compliance use. Main power must be removed to ensure safety.

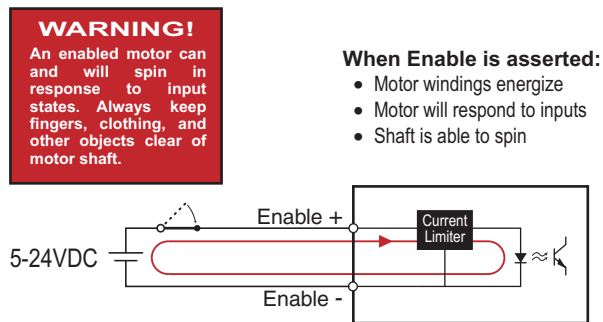

ClearPath Enable Input

Caution: When ClearPath is in “Spin on Power-Up” mode, it can spin as soon as main DC power is applied. All inputs, *including the Enable Input*, are ignored in this mode. For safety reasons, ClearPath motors never ship configured in "Spin on Power-Up" mode.

Enable Input Used as a Trigger Input. In a few ClearPath modes, the Enable input can also act as a trigger input. In these modes, briefly pulsing the Enable input low and immediately back high again causes ClearPath to perform a predefined action, such as start a move, change direction of rotation, or change velocity. See individual operation modes for more on trigger mode functionality.

INPUTS A AND B: THE CONTROL INPUTS

Inputs A and B are the main user control inputs. Their function changes automatically based on the ClearPath mode of operation you choose. In some modes simply apply a PWM signal to control velocity or torque. In other modes, set the inputs high or low to move a preset distance, ramp to a target velocity, change direction, or move until a sensor trips. For ClearPath SD models, apply standard step and direction signals to the inputs to create your own motion profiles.

Tip: Input A and Input B functions are defined at the beginning of each operational mode section.

Engineer’s Note: In all ClearPath motors, the input signals are electrically isolated from the DC power bus and motor output circuits, as

² **Exception:** when ClearPath is set to “Spin on Power Up” mode, the motor shaft can move as soon as main DC power is applied, regardless of the state of the Enable Input. ClearPath motors never ship configured in this mode.

well as from the motor case. This design feature ensures that control signals are not compromised due to induced currents from the motor, power supply, other sources of common mode noise or ground loops.

INPUT WIRING

ClearPath inputs are compatible with standard digital outputs including open collector transistor, and driven outputs from PLCs, sensors, signal generators, microcontrollers and more.

Transistor Outputs

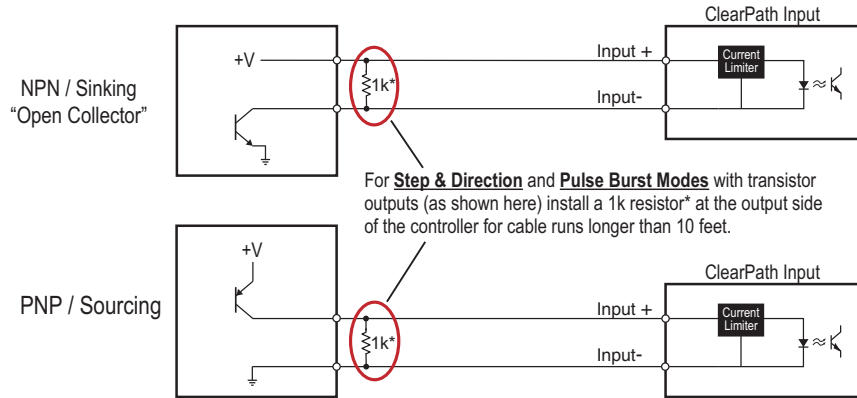

For **Step & Direction** and **Pulse Burst Modes** with transistor outputs (as shown here) install a 1k resistor* at the output side of the controller for cable runs longer than 10 feet.

***NOTE** For 5V input voltage use a 1/4W resistor
For 24V input voltage use a 2W resistor

Driven Outputs, Single-Ended

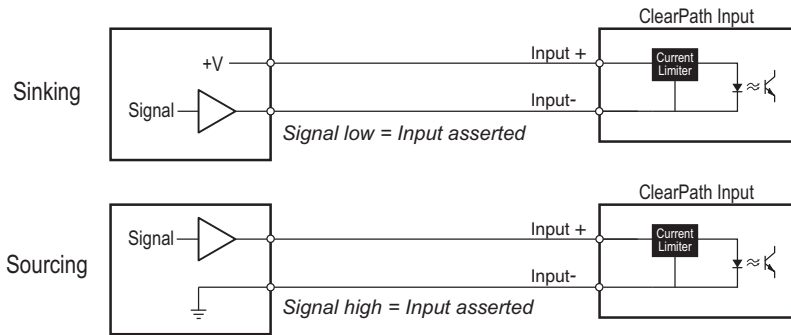

Interfacing digital outputs to ClearPath Inputs

Application Note: For additional information on selecting the proper resistor for your control input circuitry, see the [Step and Direction Timing section](#) of the user manual.

Engineer's Note: 5V differential outputs are not directly compatible with ClearPath inputs because differential drivers' guaranteed output voltage swing is typically not guaranteed to meet the ClearPath input minimum input voltage requirements.

While differential drivers may work initially, they may fail over time as the environment changes, i.e. the motor heats up, components age, and so forth. This can result in erratic operation that is difficult to debug.

CLEARPATH OUTPUT (HLFB)

ClearPath has one, user settable, multi-purpose, digital output called the HLFB Output (HLFB stands for "High-Level Feedback"). The HLFB output conveys motor and motion-related feedback to your PLC, microprocessor, or other control device.

The HLFB configuration dialog is accessed from the Advanced menu as shown below. *Advanced>High-Level Feedback*.

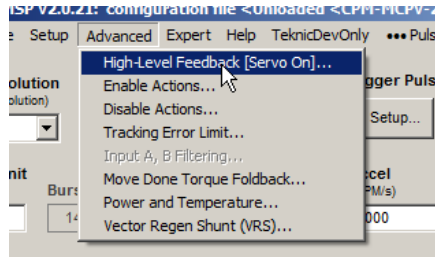

HLFB output can be used to signal:

- If the servo drive is enabled or in a shutdown (Servo On mode).
- When the commanded move is complete and settled to the user's specifications (ASG-Position mode).
- How well the motor is following your positioning or velocity commands (In Range).
- Motor speed, via PWM output (Speed Output mode).
- Motor position, via PPR output (Pulses Per Revolution).
- Motor torque, via PWM output (Torque Output mode).

Note: The HLFB circuit is not internally powered; it requires an external 5–24VDC power supply capable of sourcing/sinking at least 1mA, non-inductive. In typical HLFB applications, power is supplied by the PLC, control board, or an external supply. See Appendix D for complete HLFB specifications.

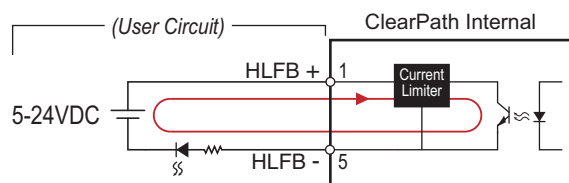

High-Level Feedback circuit

HLFB OUTPUT WIRING EXAMPLES

Any external circuit or device to be connected to the ClearPath HLFB output should conform to the guidelines below. Proper circuit design/selection greatly reduces the probability of electrically damaging the output, particularly in the event of a common production mistake such as an accidental short or reversed wiring.

HLFB AS A "SINKING" OUTPUT

The HLFB output can be used as a sinking output as shown below. This topology provides ClearPath with a high level of immunity from damage if, for example, the circuit is shorted to machine chassis. Such a short would simply make the output appear like a closed circuit.

Note: the preceding assumes the DC supply return is connected to chassis ground at one location in the machine.

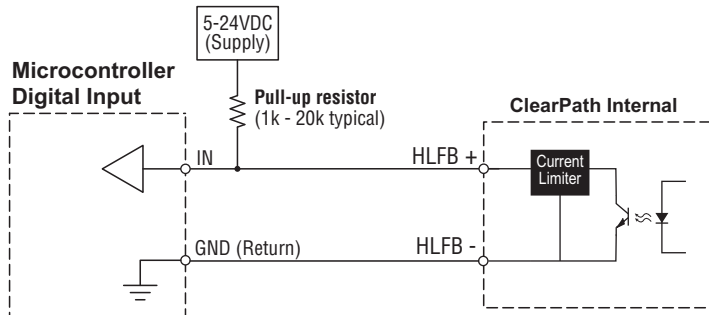
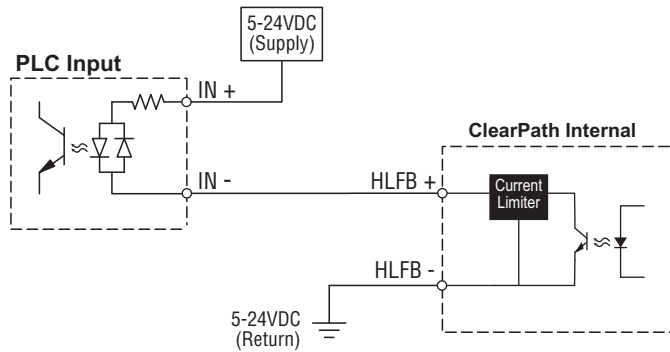

HLFB as a sinking output

HLFB AS A "SOURCING" OUTPUT

The HLFB output can be used as a sourcing switch as shown below. When using a sourcing topology, place a fuse in series with the DC supply's positive output (prior to connection to the HLFB+ pin of the ClearPath).

Use a fast acting fuse rated for 100mA max.

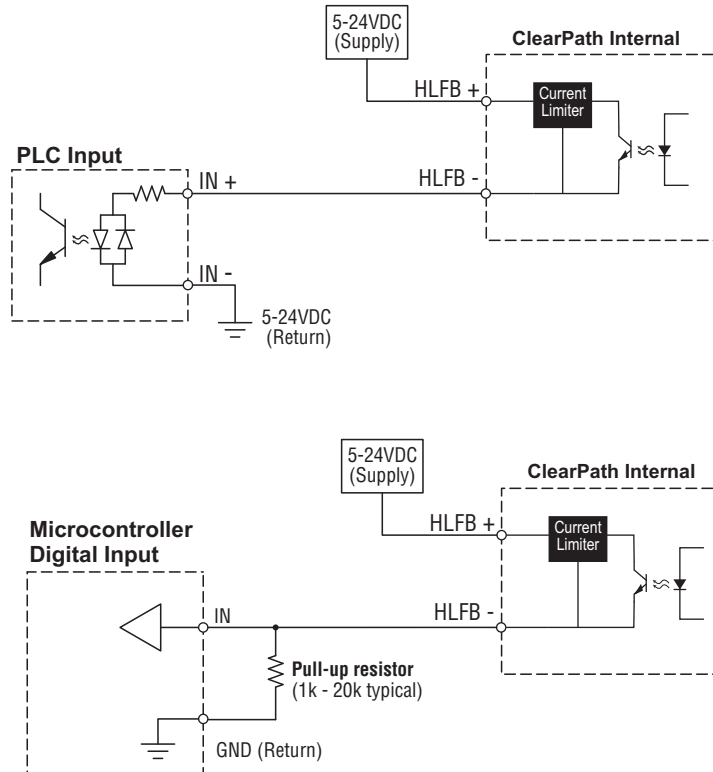

HLFB as a sourcing output

Current Limiting the HLFB Output

Whether you use sourcing or sinking topology, current supplied to the HLFB circuit from an external device should be limited to 30mA maximum. Although ClearPath includes built-in current limiting, a series connected, current limiting resistor may still be necessary to protect the HLFB Output's internal circuitry. A series resistor of 2000Ω @ 24VDC, 1100Ω @ 12VDC, 500Ω @ 5VDC can help prevent an overloaded or blown circuit.

Note: Any circuit or external device that you intend to connect to the HLFB output may already be appropriately current limited. Consult the device's user manual for its output current rating.

Tips on microcontroller inputs

- Check your microcontroller documentation to see if the inputs already have internal pull-up resistors before adding an external pull-up. If a pull-up/pull-down is too large $>10,000\Omega$, an additional lower value resistor may be required.
- Most Arduinos let you "turn on" or "turn off" internal pull-up resistors with a simple line of code. See link below for more information on Arduino inputs.

- To learn more about pull up resistors and digital circuits, Google search: "***pull up resistor for digital input***".

Arduino on the Web

For more information related to Arduino digital inputs and pull-up resistors, check out the following link:

<https://www.arduino.cc/en/Tutorial/DigitalPins>

HLFB APPLICATION EXAMPLES

HLFB Driving a LED

The HLFB circuit is not internally powered; it requires an external 5–24VDC power supply capable of sourcing/sinking at least 1mA, non-inductive. In typical HLFB applications, power is supplied by the PLC, control board, or an external supply. See Appendix D for complete HLFB specifications.

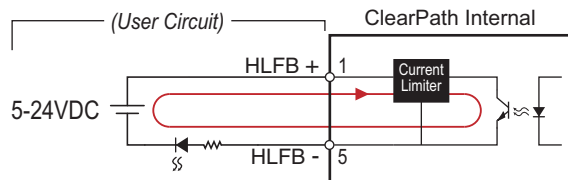

HLFB Driving LED

HLFB Driving a Brake Via Solid State Relay

ClearPath's HLFB output circuit can directly drive the input of some solid state relays (SSRs) such as the **Crydom DC60S3** shown below.

Using the **Servo On** HLFB mode, ClearPath can indirectly control power to devices such as a 24V "power-off" brake. See sketch below for example wiring details.

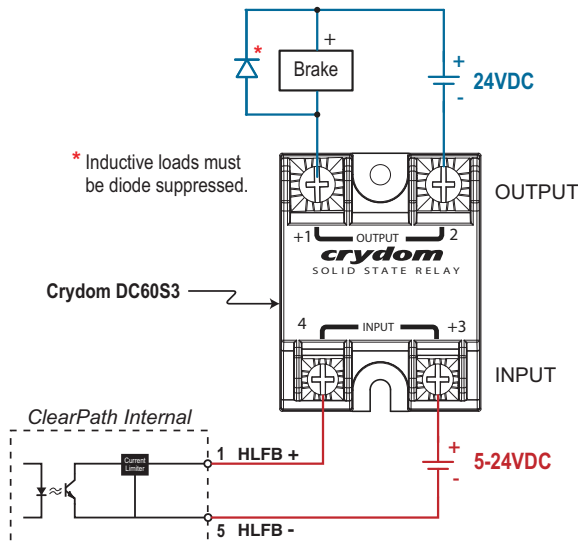

HLFB circuit controlling an SSR / brake setup

HLFB MODES: COMMON TO ALL CLEARPATH OP MODES

This section discusses HLFB modes that are available for *all* ClearPath operational modes. Later in this section we cover HLFB modes unique to Position, Velocity, and Torque operational modes.

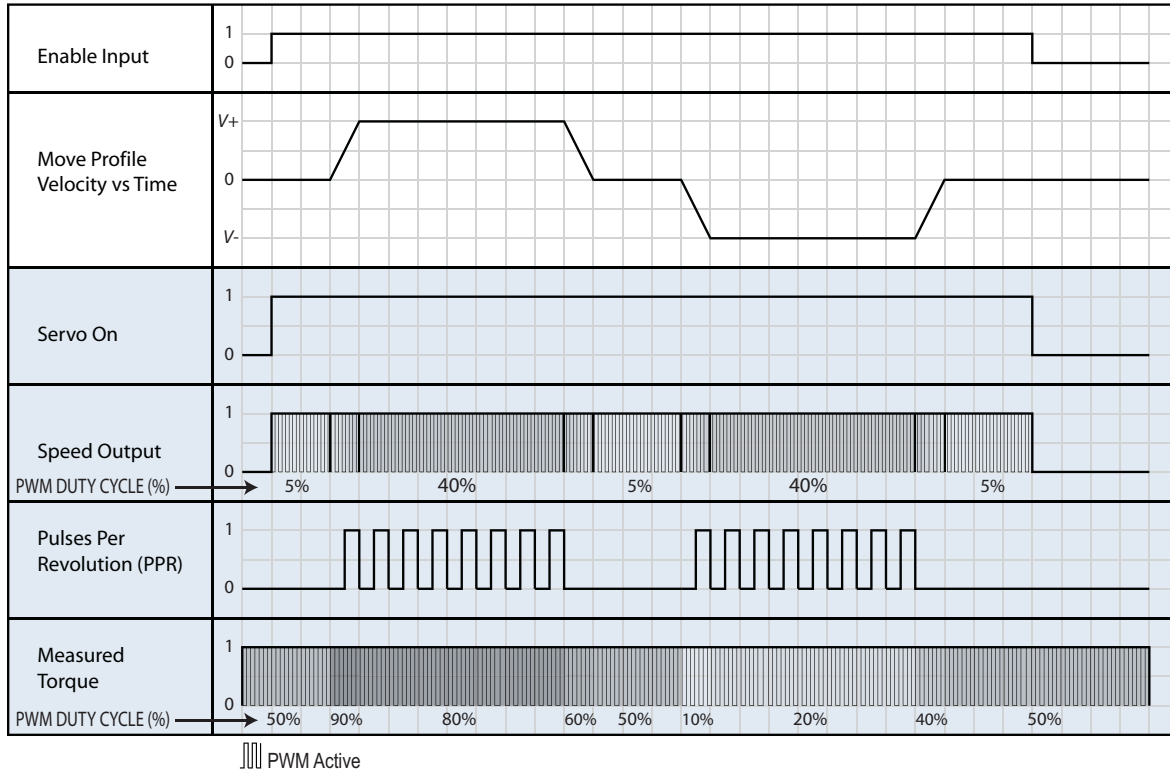

HLFB Timing: HLFB output modes available in all ClearPath op modes

SERVO ON

In Servo On mode, the HLFB output asserts (conducts) when ClearPath is enabled and not in a shutdown state. This signal is often used to monitor ClearPath for shutdowns, or as the control signal for an external brake. Note: the HLFB circuit cannot directly drive an external brake.

SPEED OUTPUT

In Speed Output mode, the HLFB outputs a 45 Hz or 482 Hz (user selectable) PWM waveform whose duty cycle varies in proportion to actual motor speed. The duty cycle scales as a percentage of the maximum motor speed configured in the currently selected operating mode.

- 5% duty cycle = 0% max speed
- 95% duty cycle = 100% max speed

The HLFB output deasserts (i.e., 0% duty cycle, "off", non-conducting) when the motor is disabled or shutdown.

Note: Speed Output is not available in the Ramp to Selected Velocity and Step and Direction operating modes.

PULSES PER REVOLUTION (PPR)

In Pulses Per Revolution (PPR) mode, the HLFB sends a user-selectable number of pulses for each revolution of the motor. The choices are: 1, 2, 4, 8, or 16 pulses per revolution.

Notes

- The frequency of output pulses is proportional to the speed of the motor.
- When motor speed is constant, the PPR pulses will exhibit a ~50% duty cycle.
- When the motor shaft is stopped, the HLFB output can be either "fixed" high or "fixed" low.
- As long as the motor maintains logic power, the output will produce pulses corresponding to motor shaft rotation, *even if the motor is disabled or in a shutdown.*

MEASURED TORQUE

In Measured Torque mode, the HLFB outputs a 45 Hz *or* 482 Hz (user-selectable) PWM waveform that varies in duty cycle between 5% and 95% to indicate direction and magnitude of motor shaft torque as follows:

- 5% duty cycle = 100% peak torque, CW direction
- 50% duty cycle = zero torque
- 95% duty cycle = 100% peak torque CCW direction

HLFB MODES: FOR CLEARPATH POSITIONING MODES

The following HLFB modes are available only in positioning op modes.

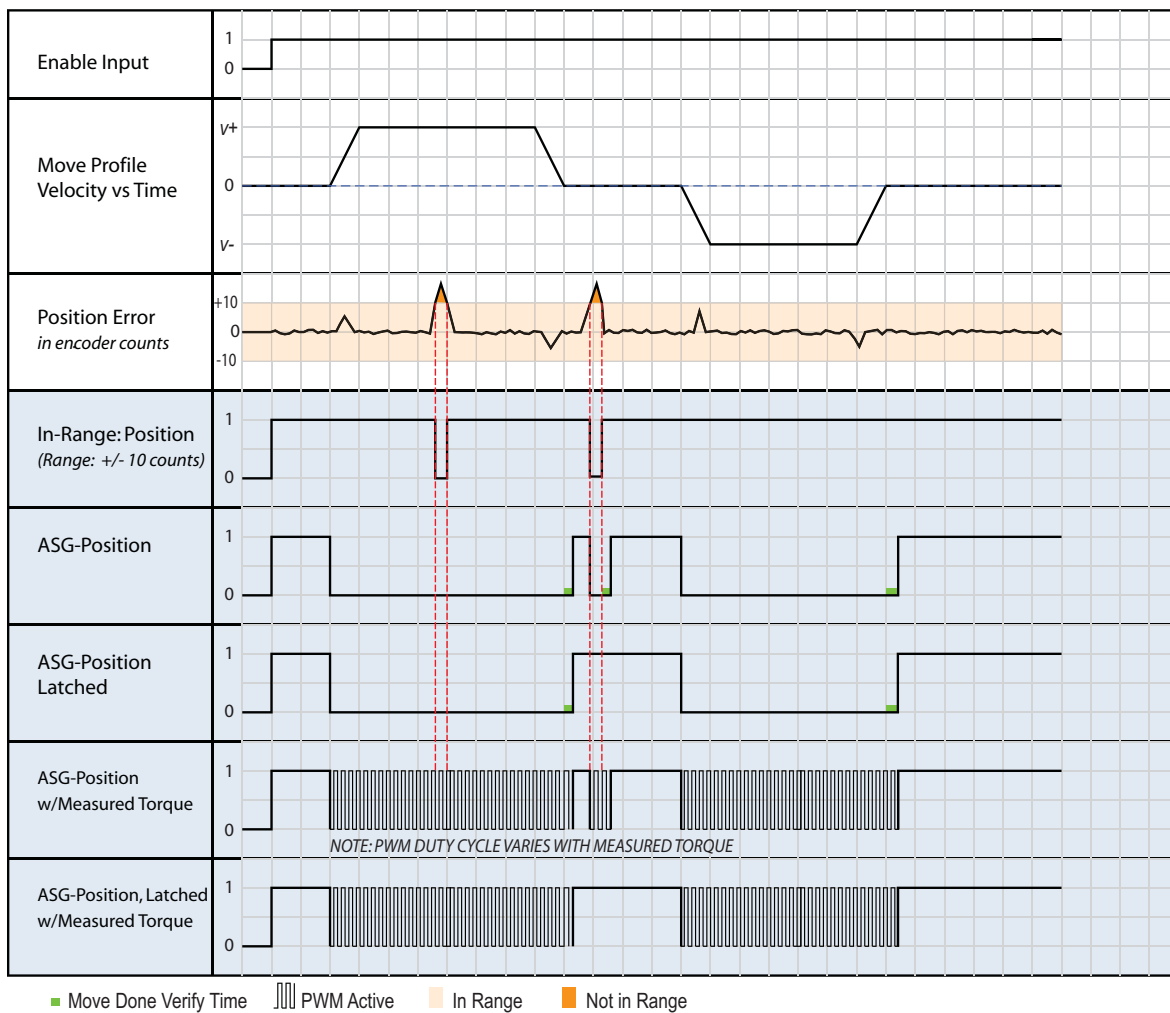

HLFB Timing: HLFB output modes available only in ClearPath positioning op modes

IN RANGE-POSITION

The HLFB output asserts (conducts) when the motor is enabled, not shutdown, and the measured motor position is In Range ($\pm X$ encoder counts) of the current commanded position. The In Range parameters are set in the HLFB Setup dialog.

ASG (ALL SYSTEMS GO) - POSITION

In ASG-Position mode the HLFB output asserts (conducts) when the motor is enabled, not in a shutdown, and is considered "Move Done" (explained below).

"Move Done" occurs when the motor has settled within $\pm X$ encoder counts of the final target position, for at least Y milliseconds (where X and Y are user-settable in the HLFB Setup dialog).

Note: The HLFB output deasserts while moving, or if the motor's actual position falls out of the $\pm X$ encoder count In-Range window.

ASG-POSITION LATCHED

ASG-Position Latched works in the same way as ASG-Position except that the HLFB output latches once asserted (conducting). The output remains asserted until the motor is disabled, goes into a shutdown, or receives a motion command.

Even if the motor is momentarily pushed "Out-of-Range" at the end of a move, the HLFB will remain asserted (conducting).

ASG-POSITION WITH MEASURED TORQUE

ASG-Position with Measured Torque works in the same way as ASG-Position except during commanded motion, the HLFB outputs a 45 Hz or 482 Hz (user selectable) PWM waveform that varies in duty cycle between 5% and 95% to indicate direction and magnitude of motor shaft torque as follows:

- 5% duty cycle = 100% peak torque, CW direction
- 50% duty cycle = zero torque
- 95% duty cycle = 100% peak torque CCW direction.

ASG-POSITION LATCHED WITH MEASURED TORQUE

ASG-Position Latched with Measured Torque is a combination of all the previous ASG-Position modes. During commanded motion the HLFB outputs a PWM waveform to indicate motor shaft torque. Once the motor reaches "Move Done" at the target position, the HLFB output latches (stays on) even if the motor is pushed "Out-of-Range" until it is disabled, goes into a shutdown, or receives a motion command.

HLFB MODES: FOR CLEARPATH VELOCITY MODES

Note: The following HLFB modes are available in Velocity operating modes only.

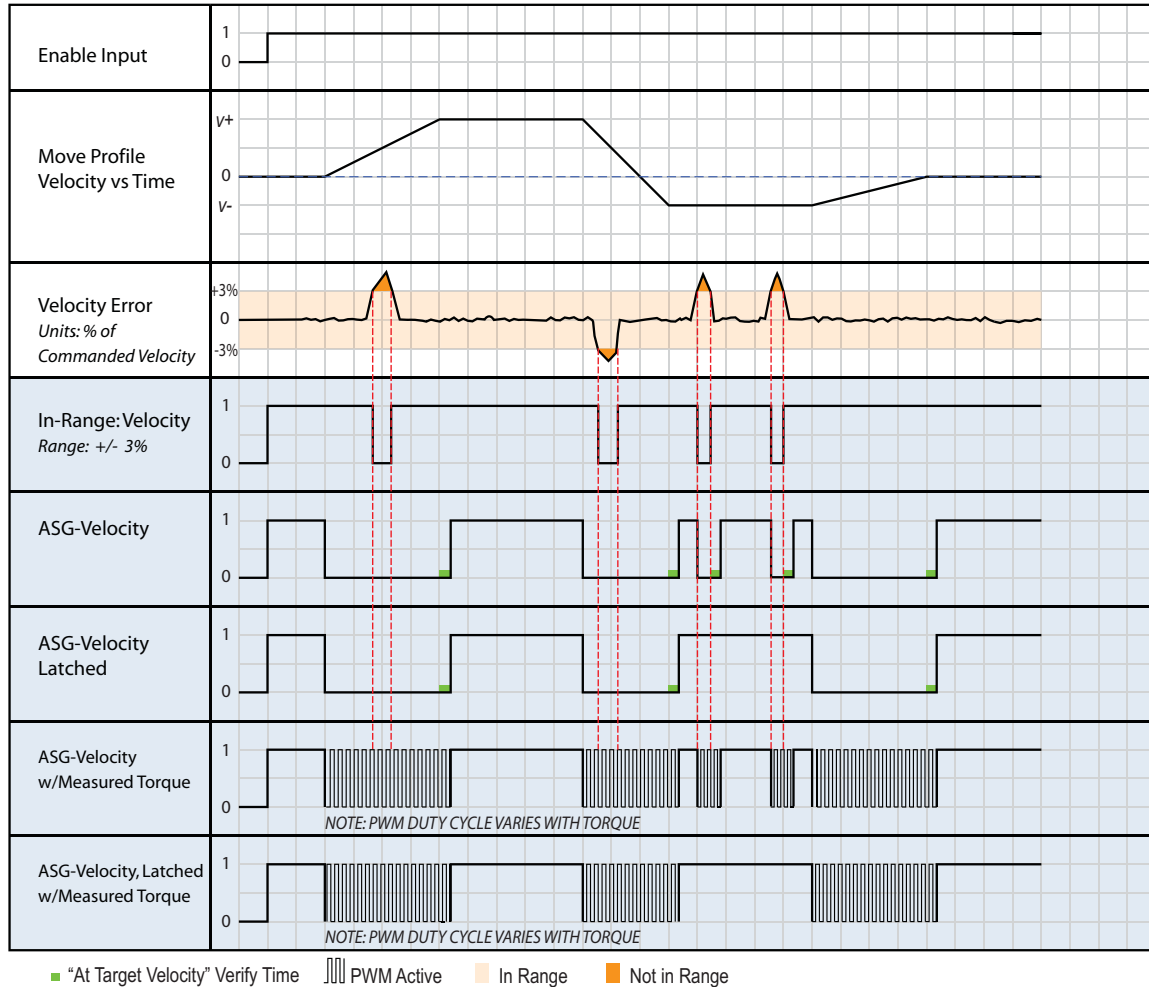

HLFB Timing: HLFB output modes available only in ClearPath velocity op modes

ASG (ALL SYSTEMS GO) - VELOCITY

In ASG-Velocity mode the HLFB output asserts (conducts) when the motor is enabled, not shutdown, and is "At Target Velocity".

"At Target Velocity" occurs when the motor has settled within $\pm X\%$ of the final target velocity, for at least Y milliseconds (where X and Y are user-settable through the MSP software).

Note: The HLFB output deasserts during periods of commanded acceleration and deceleration (i.e., when the velocity command is changing), or if the motor's actual position falls out of the $\pm X\%$ In-Range window.

ASG-VELOCITY LATCHED

ASG-Velocity Latched works in the same way as ASG-Velocity except that the HLFB output latches once asserted (conducting). The output remains asserted until the motor is disabled, goes into a shutdown, or receives a new velocity command.

Even if the motor is momentarily pushed out-of-range when being commanded to move at constant velocity, the HLFB will remain asserted (conducting).

ASG-VELOCITY WITH MEASURED TORQUE

ASG-Velocity with Measured Torque works in the same way as ASG-Velocity except, during commanded acceleration and deceleration the HLFB outputs a 45 Hz or 482 Hz (user selectable) PWM waveform that varies in duty cycle between 5% and 95% to indicate direction and magnitude of motor shaft torque as follows:

- 5% duty cycle = 100% peak torque, CW direction
- 50% duty cycle = zero torque
- 95% duty cycle = 100% peak torque CCW direction.

ASG-VELOCITY LATCHED WITH MEASURED TORQUE

ASG-Velocity Latched with Measured Torque is a combination of all the previous ASG-Velocity modes. During commanded acceleration the HLFB outputs a PWM waveform to indicate motor shaft torque. Once the motor reaches "At Target Velocity", the HLFB output latches on (Conducting) even if the motor is momentarily pushed "Out-of-Range" until the motor is disabled, goes into a shutdown, or receives a new velocity command.

IN RANGE - VELOCITY

During operation, HLFB asserts (conducts) when the motor is enabled, not shutdown, and the actual velocity is "In-Range" ($\pm X\%$) of the commanded velocity. The "In-Range" window X, can be set through the MSP software.

HLFB OUTPUT: FOR CLEARPATH TORQUE MODES

The following HLFb mode is available only in Torque operating modes.

ASG (ALL SYSTEMS GO) - TORQUE

The HLFb output asserts (conducts) when the motor is enabled, not shutdown, and is producing the commanded torque.

The HLFb output deasserts (non-conducting) when the motor is disabled, shutdown, or if the motor cannot produce the commanded torque for one of the following reasons:

- The supplied bus voltage is not high enough for the motor to produce the commanded torque at the current motor velocity.
- The motor is at or above the max motor speed setting in MSP and motor torque is limited to prevent an over-speed shutdown.

USER SOFTWARE (CLEARPATH MSP)

SECTION OVERVIEW

This section includes information on the following topics:

- ClearPath MSP System requirements
- Installing ClearPath MSP software
- Communicating with ClearPath
- Tour of ClearPath MSP
- Overview of ClearPath advanced features

MSP MINIMUM SYSTEM REQUIREMENTS

Operating System:	Win 7, 8.1, 10, 11
Processor:	1 GHz or faster
Memory:	512 MB
HD Free Space:	512 MB
Monitor:	1280 x 1024 pixels or higher
Other:	Sound card with speakers (optional)

INSTALLING MSP

Download the MSP installer from [Teknic's website](#). Follow the on-screen prompts to complete installation.

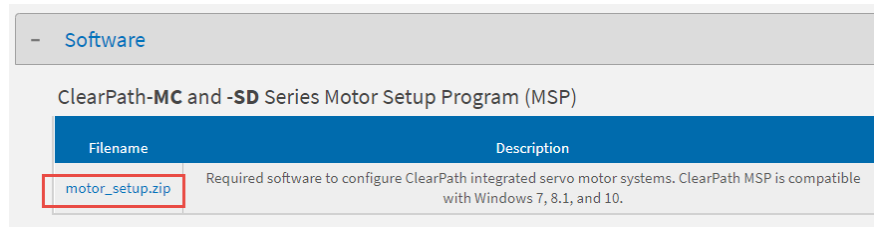

COMMUNICATING WITH CLEARPATH VIA MSP

After MSP is installed on your PC, follow the directions below to establish a communication link between your ClearPath and PC.

Note: Establishing a ClearPath communication link is required for setting operational modes, defining move parameters and options, tuning the motion system, and using the MSP Scope to analyze system performance.

ITEMS REQUIRED FOR COMMUNICATION SETUP

- A powered up ClearPath motor
- A DC power supply (24–75VDC nominal) with appropriate cables
- A PC running Windows 7, 8.1, 10, 11 with ClearPath MSP installed
- A USB cable (Type A to Micro-B) that supports high speed data transfer. **Important:** "Charging only" cables will not work.

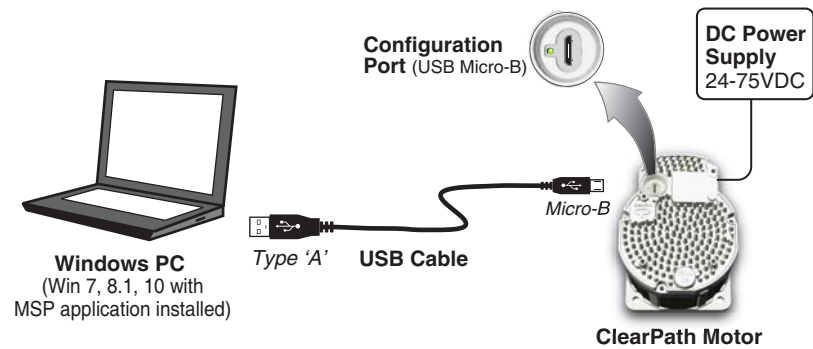

ClearPath Communication Setup

FIRST-TIME COMMUNICATION SETUP

1. **Install MSP** software on a qualified Windows PC. See previous page for Minimum System Requirements.
2. **Power up your ClearPath motor.**
3. **Connect ClearPath to your PC** with a USB Type A to Micro-B cable.
4. **Wait!** In most cases Windows will detect the connected ClearPath and install the correct USB driver software automatically. This step can take a few minutes to complete. Proceed only after Windows reports the device is installed and ready for use.
5. **Launch MSP software** by double clicking the desktop icon or selecting from the Programs menu: Teknic>ClearPath MSP> ClearPath MSP Setup Program.

Communication Notes

- MSP can communicate with only one ClearPath at a time.
- Before tuning a ClearPath, the motor must be powered up and connected to a PC running MSP.
- ClearPath does not use a PC connection during normal machine operation. You *can* always connect your ClearPath to a PC at any time to use MSP's diagnostic and troubleshooting tools.

TOUR OF CLEARPATH MSP SOFTWARE

MAIN UI OVERVIEW

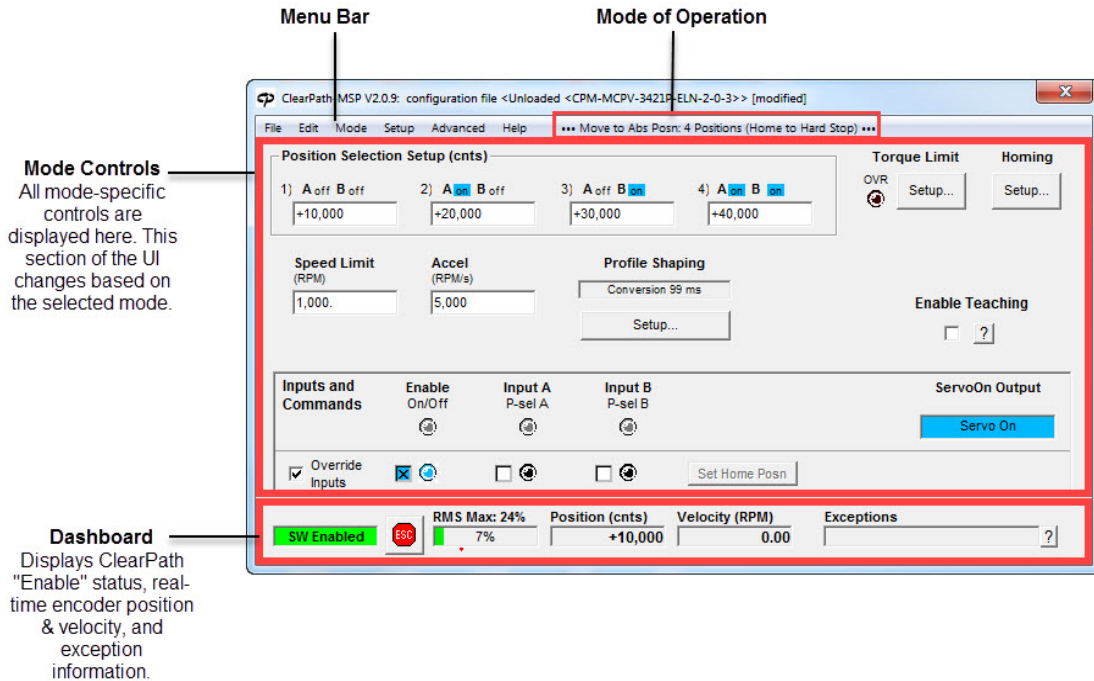

MSP User Interface

MODE CONTROLS

The Mode Controls section contains settings specific to the currently active operational mode. Mode Controls automatically change whenever a different mode of operation is selected. The Mode Controls allow you to:

- **Enter motion parameters and settings** related to the currently selected mode. These parameters include position, acceleration, velocity, torque limits, homing parameters, and more.
- **Access Soft Controls.** Soft Controls allow you to spin your ClearPath with no external hardware required. With just MSP, a powered up ClearPath motor, and a USB cable you can enable the motor, turn the inputs on and off, command motion, and monitor the HLFB output state. Soft Controls are designed for configuration, testing, and troubleshooting tasks.
- **Set homing parameters.** Homing is discussed in a separate section later in this manual.
- **Set Torque limits.** The Torque Limit settings are explained below.

TORQUE LIMIT SETUP

The Torque Limit Setup dialog lets you specify the maximum amount of torque that your motor is allowed to apply in either direction of rotation.

In addition, **Advanced Settings** allow you to specify different torque limits for each direction of travel, and dynamic torque limits based on motor position (Zone Limits).

To open the Torque Limit dialog, click the **Setup** button in the Mode Controls section (see figure below).

Direction of Applied Torque

Positive torque, (+) = torque applied in the **counterclockwise** direction of rotation (looking into the motor shaft).

Negative torque (-) = torque applied in the **clockwise** direction of rotation (looking into the motor shaft).

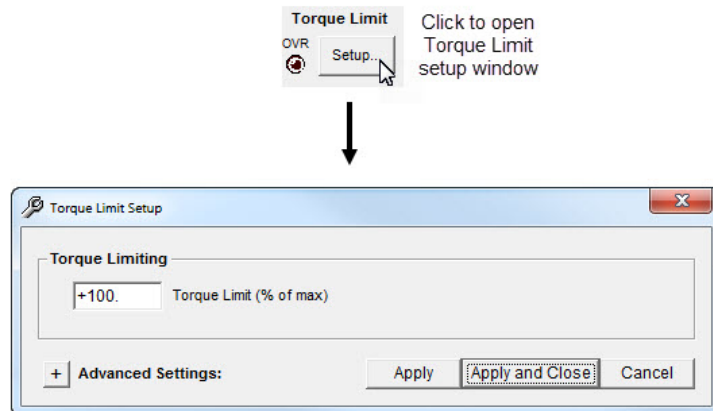

Torque Limit Setup dialog

ADVANCED TORQUE LIMIT SETTINGS

Select "Advanced Settings" to open additional torque limit settings, including **Torque Zone Limiting** and **Symmetric vs. Independent Torque Limiting** (more detail on these features below).

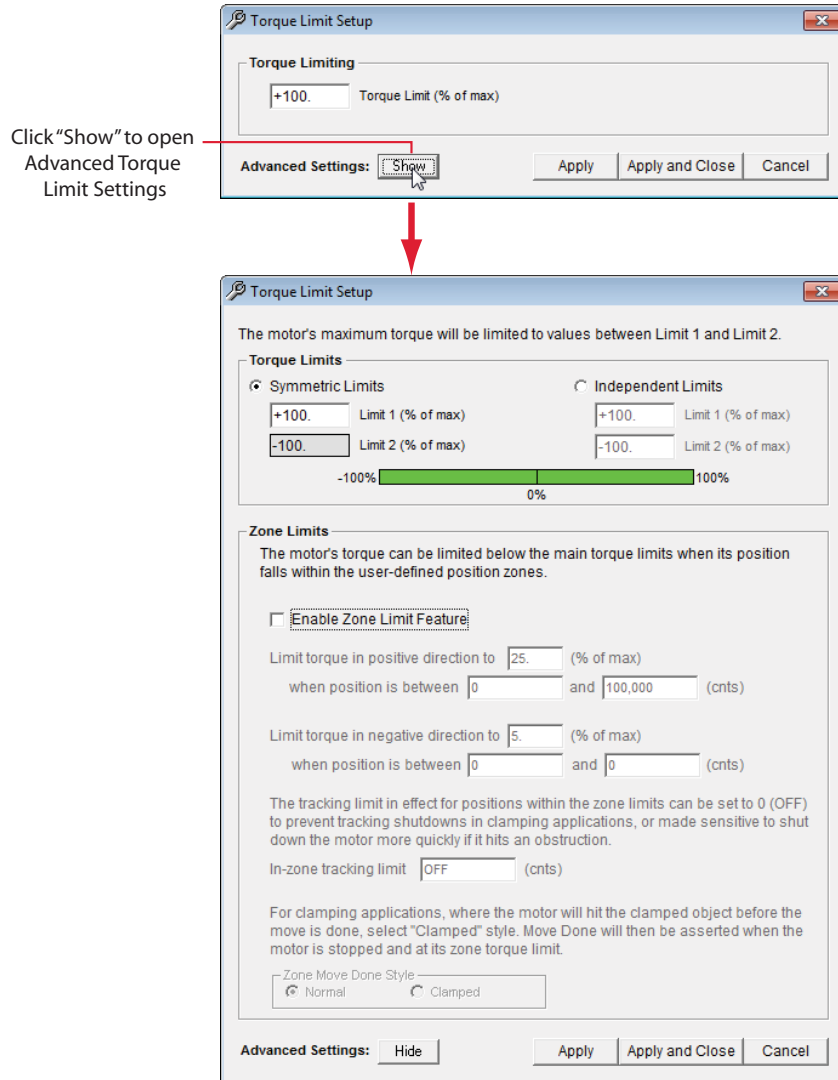

Advanced Torque Limit Setup dialog

Symmetric Torque Limits

Select "Symmetric Limits" if you want the same torque limit for both directions of rotation.

In the example below, torque is capped at 90% of the motor's peak torque in both the CW (-) and CCW (+) directions of rotation.

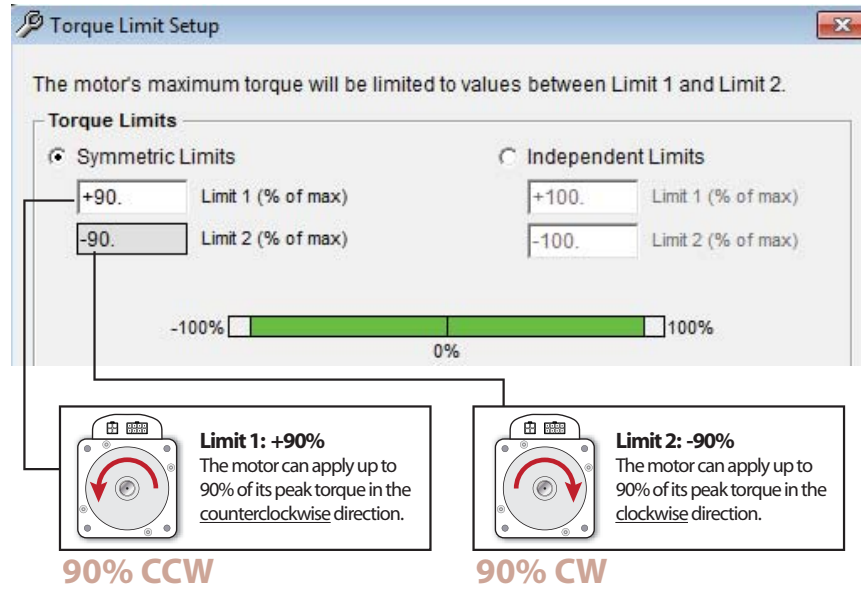

Symmetric Torque Limits

Independent Torque Limits

Select "Independent Limits" if you want to set different torque limits for each direction of travel.

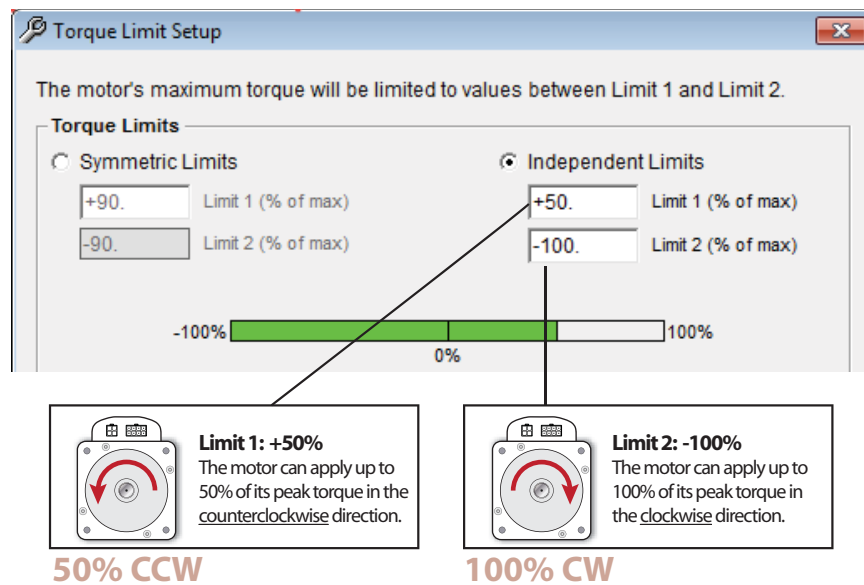

Independent Torque Limits

Zone Limits (Normal)

Use the "Zone Limits" torque feature to set up directional torque limits in different user-defined position zones along an axis of travel. See example below.

Note: The ClearPath system *must be homed* to use Zone Limits.

Zone Limits

The motor's torque will be limited when in the user-defined position ranges. Zone tracking limit can be set to 0 (Off) for clamping applications or made sensitive to shutdown the motor quickly at an obstruction.

Enable Zone Limit Feature

1 Limit torque in positive direction to (% of max)
when position is greater than and less than (cnts)

2 Limit torque in negative direction to (% of max)
when position is greater than and less than (cnts)

In-zone tracking limit (cnts)

Zone Move Done Style
 Normal Clamped

Advanced Settings:

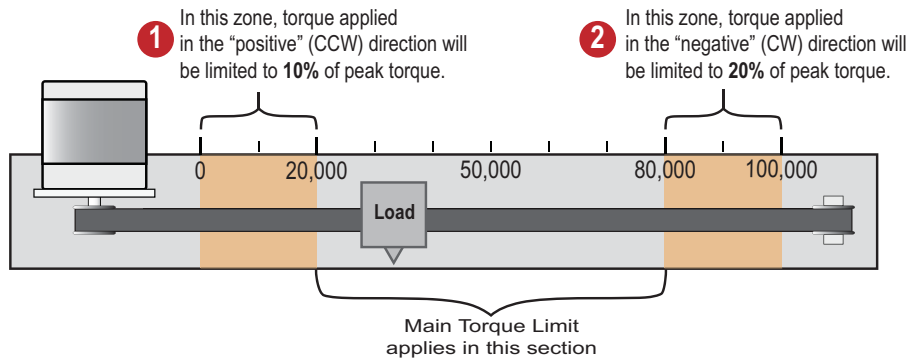

Zone Torque Limits ("Normal" Zone Move Done Style)

Zone Limits (Clamped)

Zone Limits can be particularly useful in clamping applications. In the example below, the moving platform ("Load") is designed to move to the left or right to clamp a work piece against a fixed metal block.

To set up clamping:

1. Define your Zone Torque Limits as desired. See example below.
2. Set the "In-Zone Tracking Limit" to zero (OFF). This will prevent unwanted tracking error shutdowns from occurring during clamping.
3. Set Zone Move Done Style to "Clamped".

Application Tip: When moving the motor into a clamping position, you must send enough pulses to ensure that the motor is fully pressed into the object being clamped.

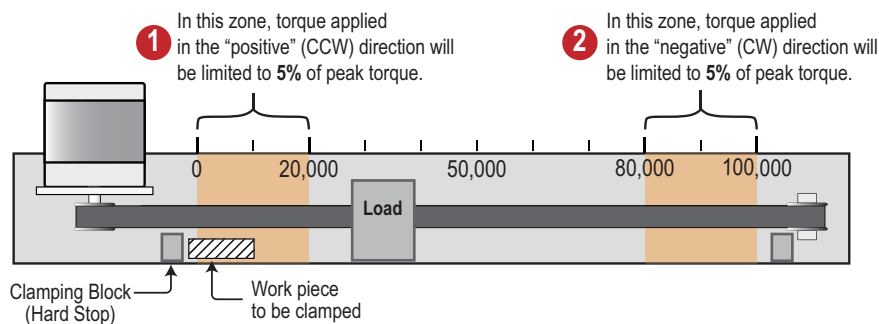
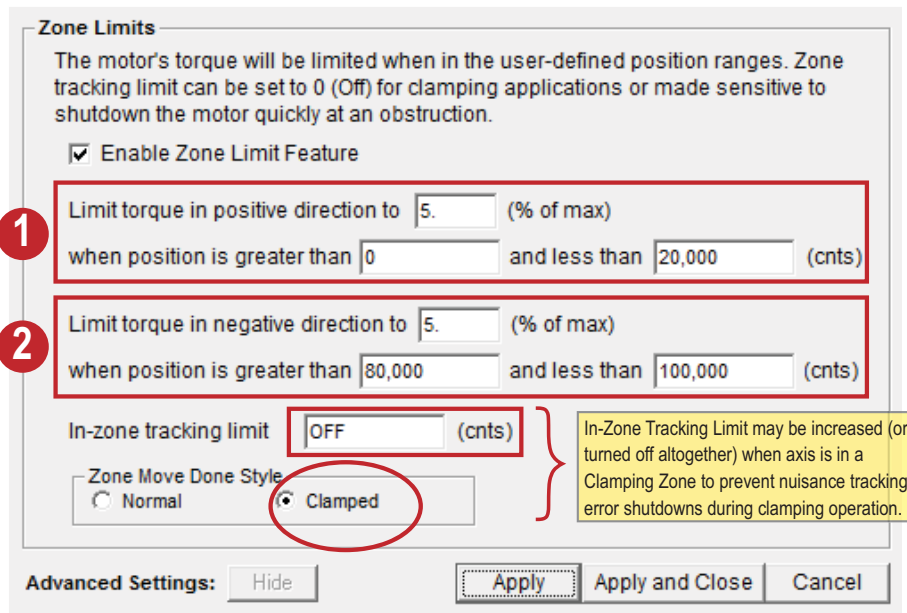

Zone Torque Limits (Clamped Move Done Style)

DASHBOARD

The Dashboard section of the UI contains several virtual gauges and readouts related to your ClearPath motor's performance and operational status.

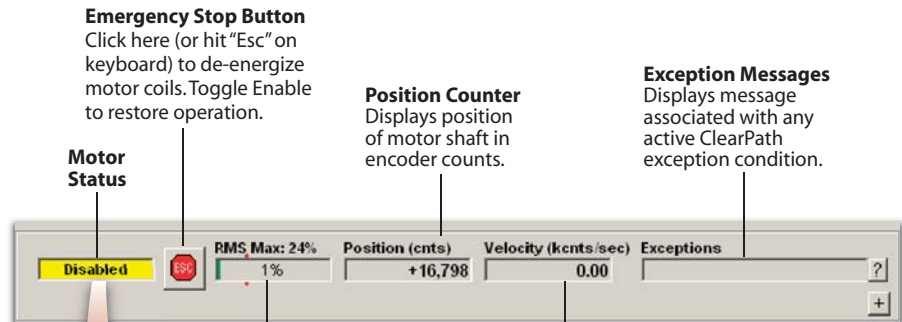

Emergency Stop Button
Click here (or hit "Esc" on keyboard) to de-energize motor coils. Toggle Enable to restore operation.

Position Counter
Displays position of motor shaft in encoder counts.

Exception Messages
Displays message associated with any active ClearPath exception condition.

Motor Status

RMS Meter
Displays real-time (and peak recorded) RMS current. ClearPath shuts down at RMS=100% to prevent burnout.

Velocity Meter
Displays motor shaft velocity in kcounts/sec or RPM.

Motor Status	Description
Enabled	ClearPath is enabled via user hardware. Caution: Motor is energized and capable of motion.
SW Enabled	ClearPath is enabled via MSP software controls. Caution: Motor is energized and capable of motion.
Disabled	ClearPath is disabled (Enable is de-asserted). Motor coils are not energized.
Lockdown	ClearPath is in a lockdown state. Caution: Motor is energized with shaft "locked".
Shutdown	ClearPath is in a shutdown state. Motor coils are not energized.
No Power	ClearPath is connected to a PC but not powered up. (This indicates low or no DC power.)

MSP MENUS

FILE MENU

Load Configuration (Ctrl+O)... Use this command to load saved ClearPath configuration files (extension .mtr) to your ClearPath.

Save Configuration (Ctrl+S)... Use this command to save your ClearPath configuration settings to a .mtr file.

Reset Config File to Factory Defaults... This command restores ClearPath to its factory default configuration. **Important:** Resetting to factory defaults will cause the motor's existing configuration data to be overwritten.

Export XML file (Ctrl+L)... Teknic support use. This command exports an XML file containing a snapshot of the current Soft Scope data and system information.

Create Support Package... Teknic support use. This command creates a .zip file containing comprehensive system diagnostic data typically for use by a Teknic engineer.

Firmware Update... Use this command to update your motor's firmware.

EDIT MENU

Cut (Ctrl-x), Copy (Ctrl-c), and Paste (Ctrl-v) are the standard Windows Edit commands.

Motor ID. Opens a window that lets you enter a name and brief description for your ClearPath if desired.

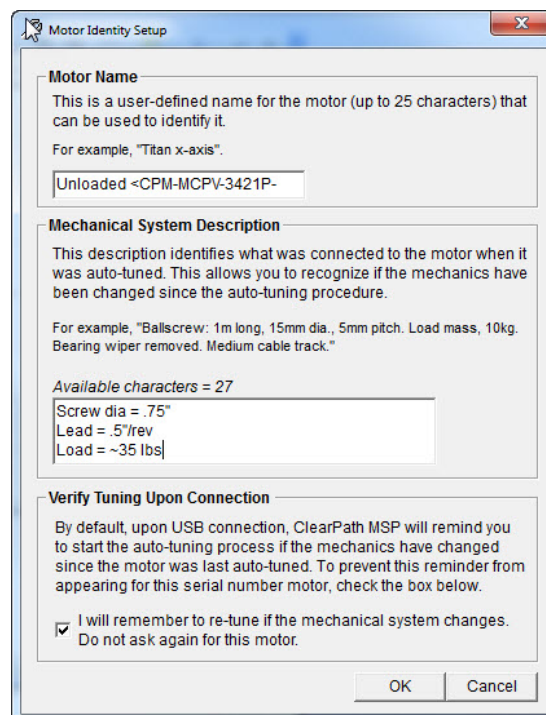

Motor Identity Setup Window

Zero Position (Ctrl+0): Sets the Position Counter to zero. Note: In certain modes, double-clicking the Position Counter directly in the UI will also zero the counter.

Reset RMS Peak This applies to the RMS Meter in the Dashboard section of MSP. Click this menu item to reset *RMS Max* (this is the maximum RMS value recorded since last motor reset).

MODE MENU

Select ClearPath operating modes from this drop down menu. Note: the number and type of available operating modes varies by ClearPath model.

Motion Generator

The Motion Generator is a special op mode that allows you to command test moves and jog your ClearPath motor using software controls only. This means you can exercise your motor and attached mechanics without wiring a single switch or sensor.

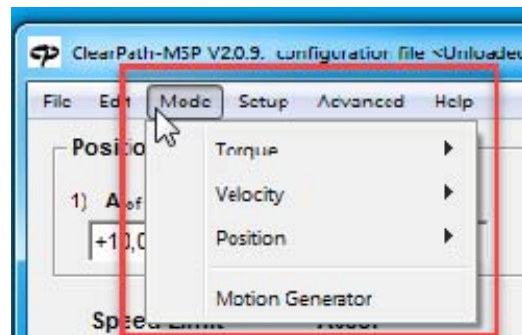

Mode Menu

SETUP MENU

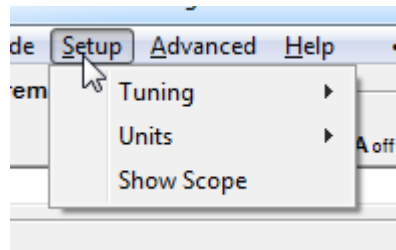

Setup Menu

Tuning>Auto-tune...

Select this menu item to begin an Auto-Tuning session. The Auto-Tune software is designed to walk you through the tuning process in a safe, step-by-step manner.

Important: To avoid personal injury, crashes, and machine damage, carefully read and follow all on-screen instructions presented during the Auto-Tune process.

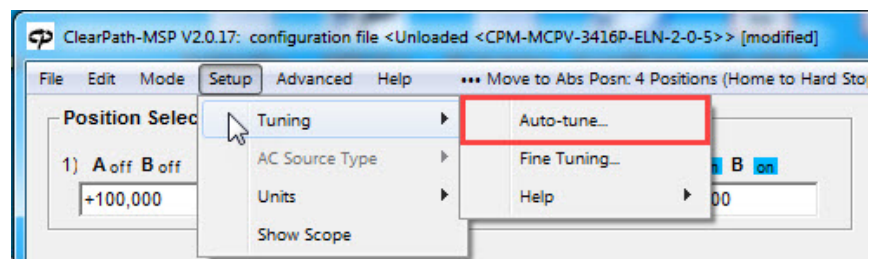

Auto-Tune in the Setup Menu

Tuning>Fine Tuning

This menu item provides a convenient way to "touch up" tuning performance. Turn on the control by checking Apply Fine Tuning. Move the slider left for quieter performance, move it right for increased dynamic stiffness. Uncheck to turn Fine Tuning off.

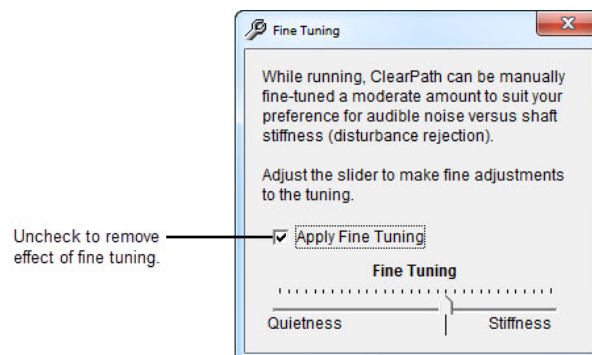

Fine Tuning Control

Units

Use the Units menu item to tell MSP which units to display for velocity and acceleration. Velocity and acceleration can be displayed in terms of encoder counts or RPM. Distances are always displayed in encoder counts.

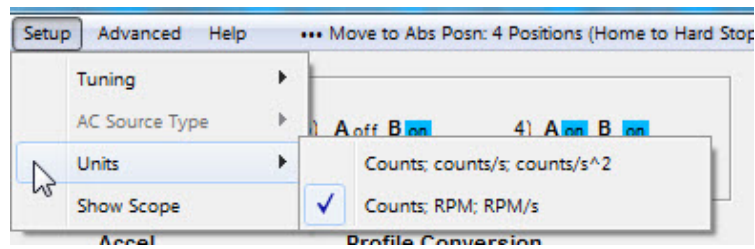

Units Selection Menu

Show Scope

This option opens MSP's built-in software oscilloscope ("Scope" for short) for troubleshooting and diagnostics.

See section, " MSP Software Scope ", for more detailed information on the features and functions of the MSP Scope.

ADVANCED MENU

Advanced Menu items are described below. The Advanced menu provides access to additional specialized features and settings.

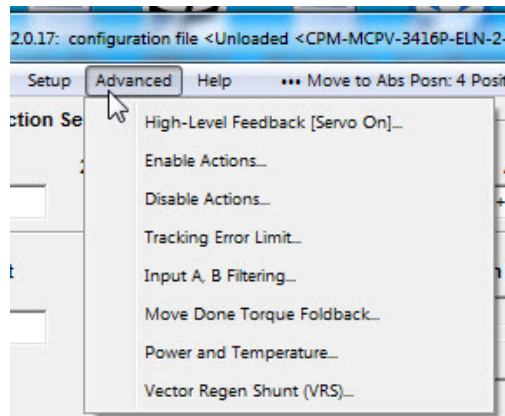

Advanced Menu

High-Level Feedback...

(Abbreviated "HLFB".) This is ClearPath's digital output. The HLFB dialog lets you choose from several different HLFB modes. HLFB can send a signal to indicate things like move completion, turn on brake, motor has shut down, and several more.

For more details on HLFB modes and timing, please refer to the *Inputs and Outputs* chapter of this manual.

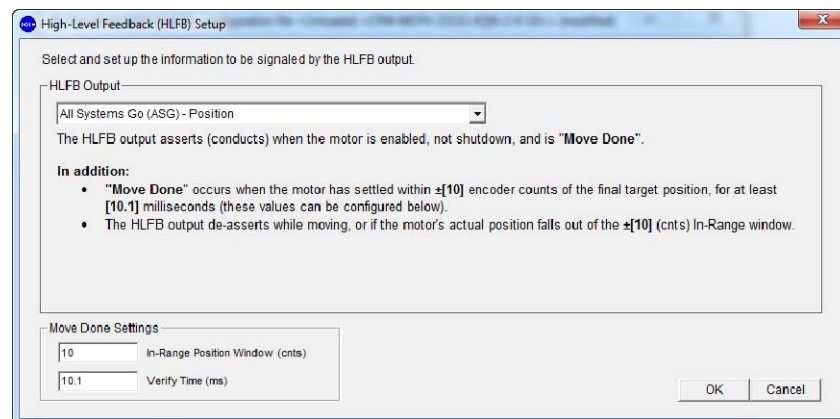

High-Level Feedback dialog (set to ASG (All Systems Go) mode)

Enable Actions...

Select this menu item to configure ClearPath's **Position Recovery** feature. The Position Recovery feature returns your ClearPath motor to its last commanded position if it is moved while disabled, or if main DC bus power drops out temporarily. See use cases below.

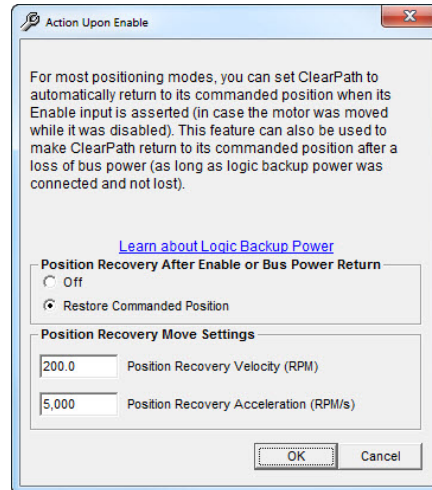

Action Upon Enable dialog

Position Recovery: Example #1

Your motor was operating normally, but then went "disabled" due to a shutdown. While disabled, it was moved an unknown distance from its last commanded position. You need it to return to its last known position the next time it is enabled. Note: Main DC bus power must be on at all times in this scenario.

Result

If Position Recovery is on, and if Homing is set to "Home on first enable after power up" (or turned off) enabling the motor will cause it to automatically return to its last commanded position at the specified velocity and acceleration.

Position Recovery: Example #2

Your motor was operating but then loses DC bus power for a short period of time. You need the motor to return to its last commanded position when main DC power is restored. Note: a POWER4-HUB with uninterrupted Logic Backup Power is required in this scenario.

Solution: If Position Recovery is active, and the Logic Power Backup Supply from the POWER4-HUB is uninterrupted, when main DC bus power is restored the motor will automatically return to its last commanded position.

Disable Actions...

This dialog lets you tell ClearPath what stopping method to use when the motor is disabled, either dynamic braking, decelerate under power, or coast to a stop.

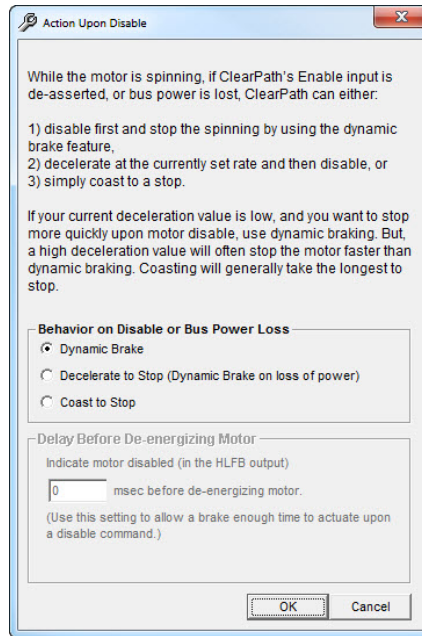

Action Upon Disable

Tracking Error Limit...

The Tracking Error Limit tells ClearPath how much positional error to allow before throwing an exception and shutting down.

Tracking Error is the difference between ClearPath's *commanded* position and its *actual* position (in units of encoder counts). The phrase "Tracking error" is used interchangeably with the phrase "position error" throughout this manual.

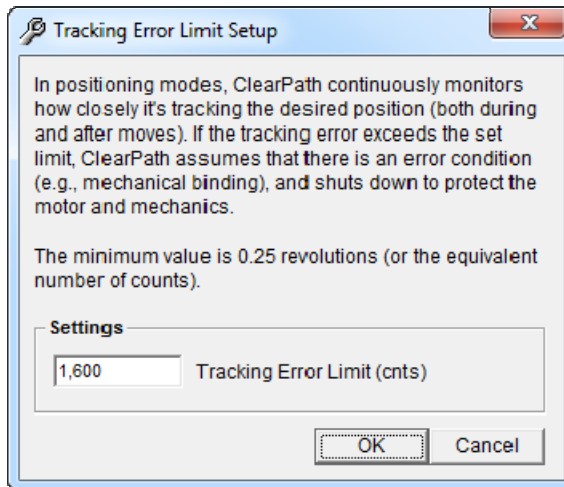

Tracking Error Limit Setup

Input A & B Filtering...

This dialog lets you independently set digital filtering for the two ClearPath inputs. This can be helpful when "bouncy" mechanical switches are wired to the inputs.

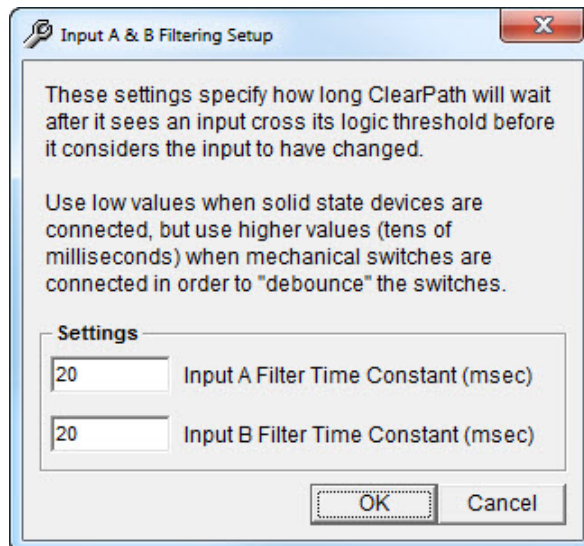

Input Filtering Setup

Move Done Torque Foldback...

This dialog allows you to automatically limit ClearPath's available torque when ClearPath has achieved "Move Done" status.

The Move Done Criteria consist of two parameters: the "In-Range Window" and the "Verify Time". For complete information, please read the dialog window below.

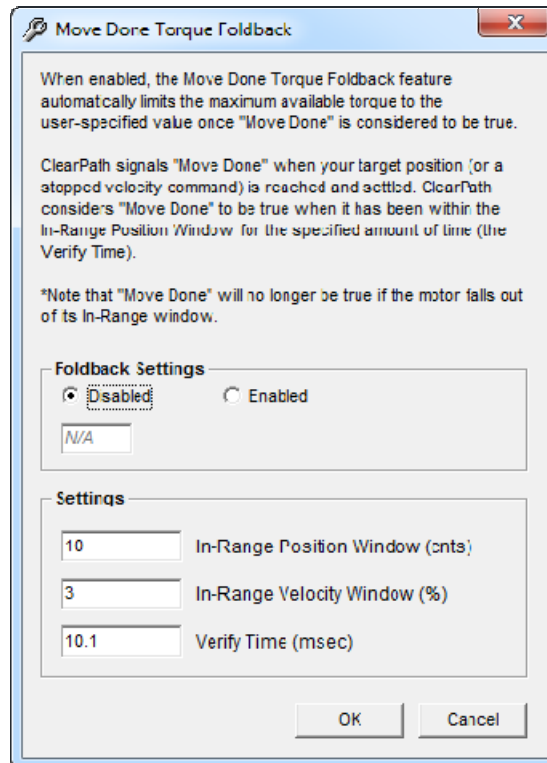

Move Done Criteria Setup

Power and Temperature...

Use this dialog to:

- Tell ClearPath whether to shut down or just issue a warning when DC bus voltage falls below the minimum operating voltage setting as can happen when a power supply droops.
- View the current temperature of your ClearPath drive board.
- Set the temperature threshold at which ClearPath throws an over-temperature shutdown. This should typically remain at the default setting.

Status	Power Exception	Exception Type
<input checked="" type="radio"/>	Bus went below the minimum operating bus voltage	<input checked="" type="radio"/> Shutdown <input type="radio"/> Warning
<input checked="" type="radio"/>	Bus Voltage Overload	<input checked="" type="radio"/> Shutdown only

Power Exception Parameters

62.00 Minimum operating bus voltage (VDC)

8 Bus Current Trip Point (A)

Drive Temperature (°C)

Measured	Maximum
46	83

Power and Temperature Settings

Vector Regen Shunt (VRS)...

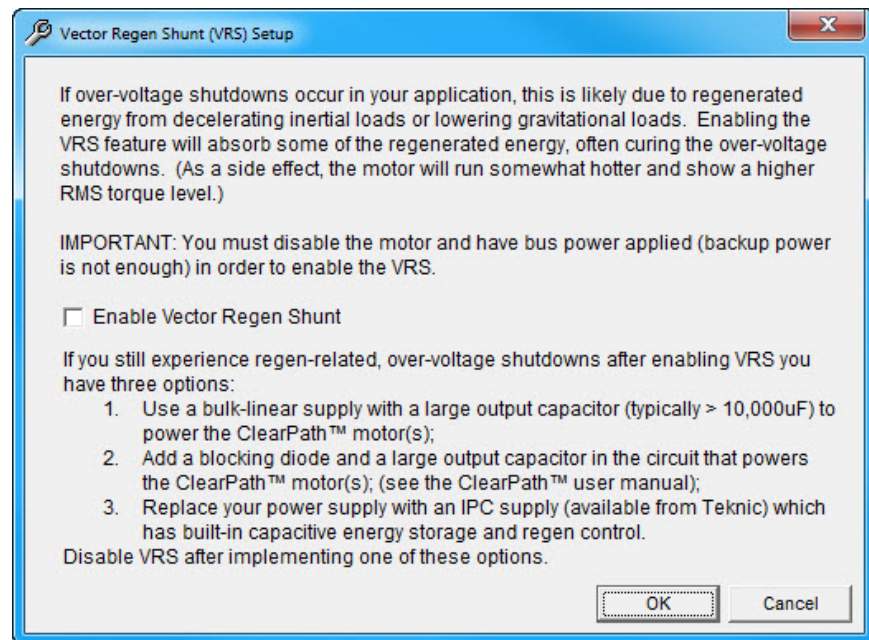

Vector Regen Shunt (VRS) Setup

HELP MENU

The Help menu provides additional resources for topics you may have questions on.

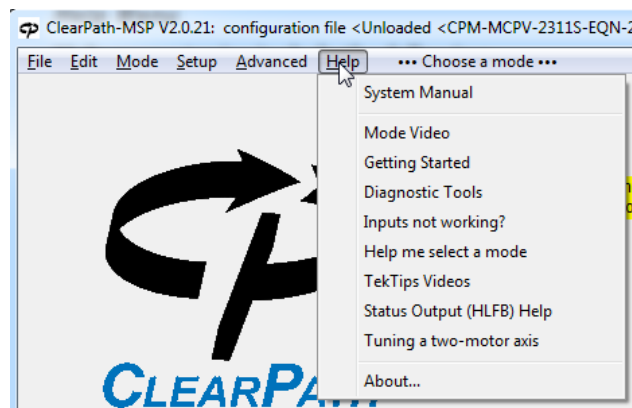

Help Menu

Help menu topics include the following:

- **System Manual:** Select this option to navigate directly to the user manual for your specific product.
- **Mode Video:** Select this option to navigate to the demo video or manual.
- **Getting Started:** This option will take you directly to a video that explains how to initially set up your ClearPath motor. The video walks you through different MSP features and parameters. The video also includes a brief demo of ClearPath testing with MSP.

- **Diagnostic Tools:** Click this option to watch a video that explains how to use MSP's built-in software oscilloscope and diagnostic tools for troubleshooting and performance measurement.
- **Inputs not working?:** This resource will take you to a simple step-by-step process for how to test the ClearPath inputs if you are trying to troubleshoot a potential issue.
- **Help Me Select a Mode:** Select this option to navigate to the Teknic "Videos" page. From there, you can view various demo videos featuring each ClearPath operational mode.
- **TekTips Videos:** This option will take you to the Teknic "Videos" page where you can watch different tutorials on topics ranging from Auto-Tune to Teknic's RAS feature to the differences between Stepper motors and ClearPath servo motors.
- **Status Output (HLFB) Help:** Click this menu item to be taken directly to the "HLFB" section in the ClearPath User Manual.
- **Tuning a two-motor axis:** Select this option to learn more about the process for tuning a dual-driven axis.
- **About...:** This menu item will give you a summary of your ClearPath specifications including the model number, hardware version, firmware version, MSP Installer version, serial number, and other useful information.

MSP SOFTWARE SCOPE

This section contains a discussion of the main features and functions of the MSP Scope.

OVERVIEW

The MSP software oscilloscope (or just "scope") takes real-time streaming data from your ClearPath motor and plots it on a virtual display similar to that of a hardware oscilloscope.

The scope can be used to display your motor's real-time shaft torque, position error, commanded velocity, acceleration, and more. The scope is an indispensable tool for those who routinely analyze and troubleshoot electrical, mechanical, and motion-related problems on machines with ClearPath motors.

To open the scope in MSP navigate to **Setup>Show Scope**.

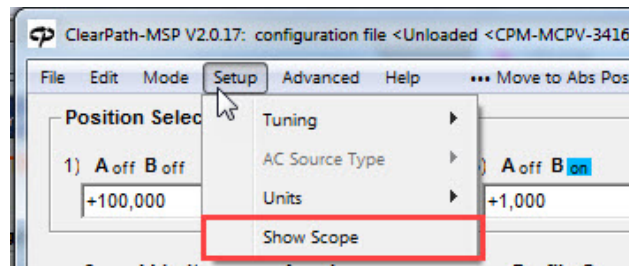

Opening the MSP Scope

SCOPE FEATURES

- 13 scope variables
- 4 trigger modes
- Adjustable time base, range, reference "zero" level, and trigger position
- Dual Trace Capability: 2 stored traces + 2 live traces.
- Twelve trigger source presets
- Click-and-drag cursors for precise time and amplitude measurements
- Strip Charts that synchronously display motion, drive, and I/O event timing
- Envelope mode that continuously stores and updates maximum and minimum trace values over a user-defined period of time.
- Cursor "Zoom" feature to help you quickly magnify a user-defined area of the scope display

SCOPE USER INTERFACE & CONTROLS

The MSP Scope display was designed to look and work like a hardware oscilloscope. MSP Scope has 10 major vertical divisions (the time axis), and 8 major horizontal divisions (the amplitude axis).

See below for a list of MSP Scope features numbered on the figure below.

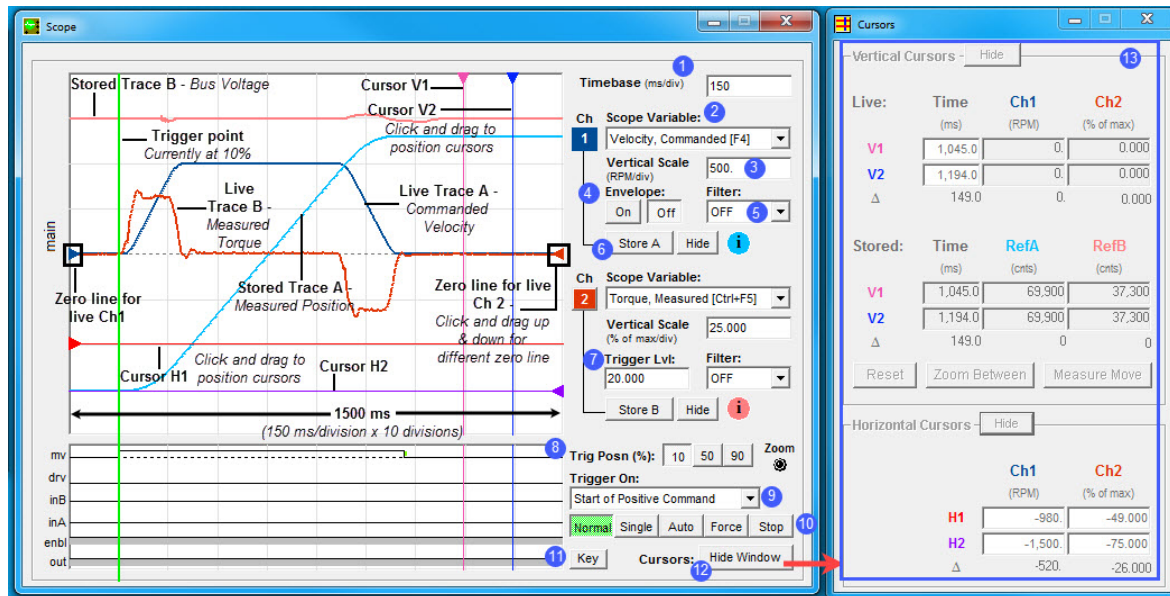

MSP Scope and Cursors window

1 The Timebase field lets you set the scale of the time axis (in units of ms/division). This setting lets you control how a waveform fits (horizontally) on the scope display.

2 The Scope Variable drop down menu lets you select any of 13 ClearPath motion control variables to display. The Scope variables are listed below and described in detail on the next page.

MSP Scope Variables (see next page for full descriptions)

- Position Error
- Commanded Velocity
- Measured Torque
- Utilized Torque
- Velocity Error
- Bus Voltage
- Max Phase Voltage
- Commanded Torque
- Measured Position
- Commanded Acceleration
- Commanded Jerk
- Torque Error
- Measured Velocity

Scope Variable	Definition
Position Error [F3]	Position Error (also referred to as "Tracking Error") displays the difference between commanded position and actual position.
Velocity, Commanded [F4]	Commanded Velocity displays the actual commanded velocity vs. time motion profile coming from your controller or MSP.
Torque, Measured [F5]	Measured Torque graphs the actual torque that the motor is using during (as a percentage of peak torque).
Torque Utilization [F6]	Torque Utilization plots the percentage of <i>available</i> peak torque in use over time. This is particularly useful if you have a power limited motor and need to know how close to available peak torque the motor is operating.
Velocity Error (Gated)	Velocity Error shows the difference between commanded velocity and actual velocity during constant velocity command.
Bus Voltage	Bus Voltage displays ClearPath's DC bus voltage in real time.
Max Phase Voltage	Max Phase Voltage displays the greatest voltage running through ClearPath's phase wires.
Torque, Commanded	Commanded torque displays the required torque to complete the given command from your controller or MSP.
Position, Measured	Measured Position displays the actual position of ClearPath in terms of encoder counts.
Acceleration, Commanded	Commanded Acceleration shows the actual acceleration command coming from your controller or MSP.
Jerk, Commanded	Commanded Jerk displays the derivative of the commanded acceleration.
Torque Error (peak)	Torque Error displays the difference between commanded and actual torque.
Velocity, Measured	Measured Velocity displays ClearPath shaft velocity in either RPM or encoder counts per second.

3 The Vertical Scale lets you change the scale of the amplitude axis in terms of units per division. This allows you to control how a waveform fits (vertically) on the Scope display.

4 Envelope Mode allows you to capture the minimum and maximum amplitude envelope of a displayed variable, typically generated over many sweeps of the scope.

Important note: *To use Envelope Mode, you must be on Channel 1, and running a repeat move, and have the scope's trigger mode set to "Normal".*

5 Filter “cleans up” the appearance of the live trace by removing higher frequency data content. This has an averaging effect on the displayed waveform that will generally reduce visual clutter.

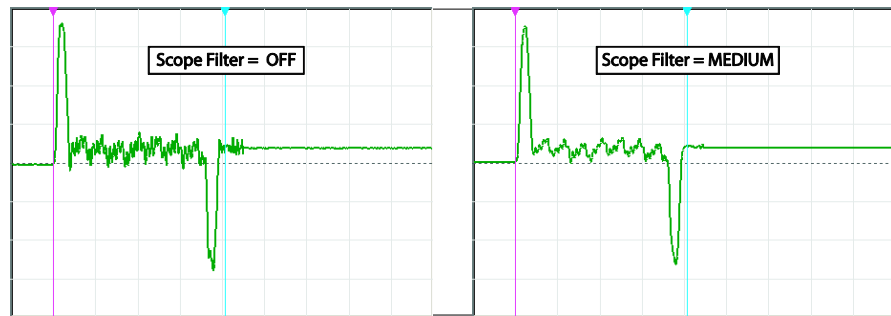

Effect of Scope Filter on trace display

Note: The Scope Filter has no effect on motor performance. *It only changes the appearance of displayed scope data.*

Note: Be careful! A high filter setting may filter out meaningful data (fast peaks in particular).

Tip: In most cases Scope Filter can be left “OFF” or at the lowest non-zero setting.

6 Trace Storage controls allow you to save and display one trace per channel on the scope display. Just capture a waveform and click either the “Store A” or “Store B” button. The selected trace is then stored and displayed in either pink (Store A) or blue (Store B). Hide or show either stored trace by clicking its associated Show/Hide button.

7 The Trigger Level lets you select the amplitude (of the variable you are currently measuring) at which the scope will trigger.

Note: Trigger Level can only be used when Trigger Source is set to “Rising Slope” or “Falling Slope”.

Tip: Use Trigger Level when the Trigger Mode is set to “Normal” or “Single” to facilitate waveform display at a fixed trigger point.

8 Trigger Position buttons allow you to place the trigger point on the left, middle, or right side of the scope display grid. This is useful for viewing events on the scope that occur before, during, or after the trigger event.

9 The Trigger Source ("Trigger On") drop down menu lets you choose what condition(s) must be met before scope data collection begins. The following Trigger Source options are available:

If Trigger Source is set to:	MSP Scope will:
Start of Positive Command	Trigger at the start of any positive move; useful for tuning.
Start of Negative Command	Trigger at the start of any negative move; useful for tuning.
Start of Any Command	Trigger at the start of any move (positive or negative); useful for assessing bi-directional tuning performance.
End of Positive Command	Trigger at the end of any positive move; useful for assessing settling performance.
End of Negative Command	Trigger at the end of any negative move; useful for assessing settling performance.
End of Any Command	Trigger at the end of any move (positive or negative); useful for assessing bi-directional settling.
End of Positive Settled Move	Trigger at the end of any positive move after Move Done criteria are met; useful for assessing settling performance.
End of Negative Settled Move	Trigger at the end of any negative move after Move Done criteria are met; useful for assessing settling performance.
End of Any Settled Move	Trigger at the end of any move (positive or negative) after Move Done criteria are met; useful for assessing settling performance.
Voltage/Torque/Speed Limit	Trigger on first occurrence of saturation (voltage <i>or</i> torque) or upon speed limiting; useful for determining which moves (or segments of moves) exceed these thresholds.
Drive Shutdown or Exception	Trigger on the assertion of an exception or safety shutdown; useful for determining the operational status at the time of a fault.
Rising Slope	Trigger on the rising edge of the active waveform.
Falling Slope	Trigger on the falling edge of the active waveform.

10 Trigger Mode settings allow you to specify exactly when to start data acquisition. These controls are analogous to the trigger modes found on a hardware o-scope.

- **Normal** - Causes scope data collection to start whenever a valid trigger source is detected.
- **Single** - Works the same as *Normal* mode, except it captures only a single data set when a valid trigger source is detected. After the single sweep capture, data collection automatically stops.
- **Auto** - This is the scrolling, “always on” setting. Data is continuously collected, refreshed, and displayed regardless of the trigger source setting.
- **Force** - Forces the scope to trigger immediately, regardless of trigger source setting. As with Single mode, only one data set is collected and displayed; then data collection stops.
- **Stop** – Causes scope data collection to stop.

11 Legend - Scope Traces - This is a visual key to the symbols you will see on the MSP Scope display.

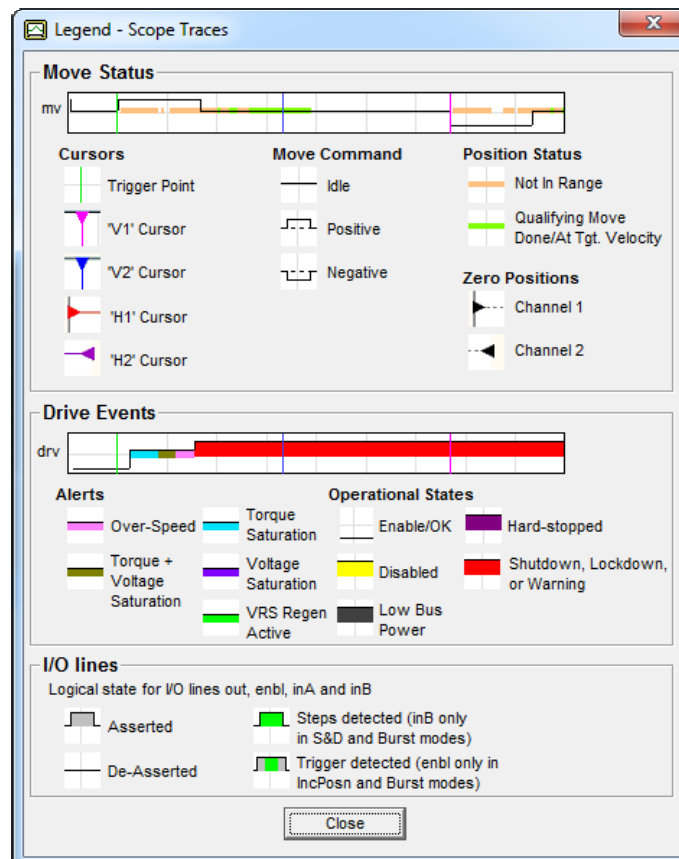

MSP Scope Legend

12 Show/Hide Window opens or closes Cursor Control Window.

13 Cursors Window (see window at right.)

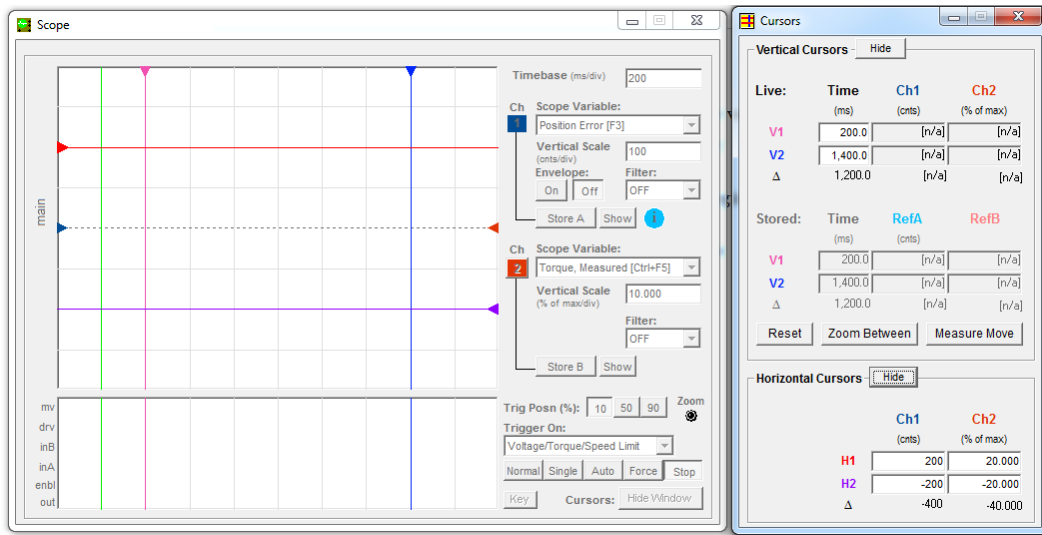

MSP Scope Display (left) and Cursors window (right)

The Cursors window features:

- **Real-time, numeric display** of cursor data, including delta calculation showing the difference between cursor values.
- **"Zoom Between" button** allows one-click magnification of the area of the scope display between the vertical cursors.
- **"Measure Move" button** automatically places the vertical cursors at the beginning and end of a "live" move.
- **"Hide" and "Show" buttons** let you view or hide vertical and/or horizontal cursors as desired.
- **"Reset" button** automatically relocates cursors to their default, initial positions.

STRIP CHART

The Strip Chart can display a number of additional events and conditions that occur in sync with the primary waveform capture. Using the Strip Chart you can view move status (mv), drive events (drv), and I/O states in real time. And, because the Strip Chart display is always auto-synchronized to the main scope trace, there are no settings to deal with.

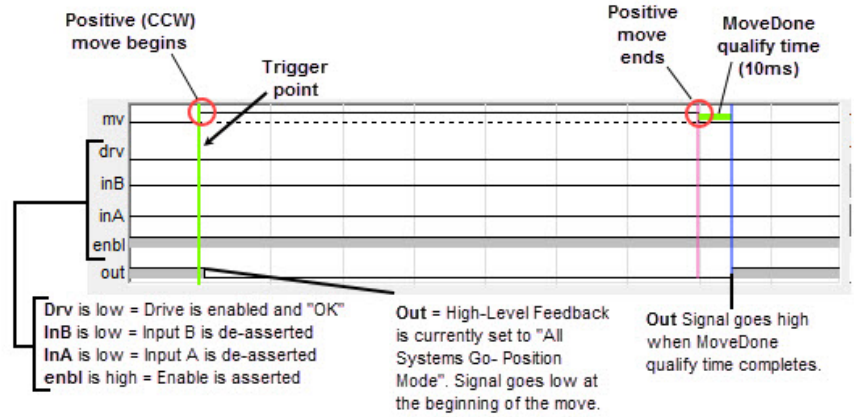

MSP Strip Chart

OPERATIONAL MODES: MCVC AND MCPV

TABLE OF OPERATIONAL MODES: MODELS MCVC AND MCPV

This section lists the operational modes for ClearPath models **MCVC** and **MCPV** only. ClearPath SD (step & direction) models are covered in the section *Operational Modes: SDSK and SDHP* (which follows this section).

ClearPath Models MCVC and MCPV Operational Modes List			
Velocity Control Modes	MCVC	MCPV	Description
Spin On Power Up (link)	✓	✓	Just turn on power and smoothly ramp to your preset velocity. For when all you need is reliable, constant velocity from a brushless motor, and a bare minimum of wiring. It doesn't get any easier than this. Link
Manual Velocity Control (link)	✓	✓	Fine control of velocity from zero to max velocity at the turn of a knob. Remembers your last set velocity or resets to zero velocity when motor is enabled.
Ramp Up/Down to Selected Velocity (link)	✓	✓	By changing digital inputs (from your PLC, switches, etc.), ClearPath will smoothly ramp to one of four preset velocities.
Follow Digital Velocity Command (link) <i>Bipolar PWM Command (with Inhibit)</i>	✓	✓	Connect a digital waveform (PWM or frequency) from your PLC or other device, and ClearPath will run at a velocity proportional to the waveform. Or, use the PWM output from an H-bridge driver of a brushed motor setup and ClearPath becomes a high-performance drop-in replacement.
Follow Digital Velocity Command (link) <i>Bipolar PWM Command with Variable Torque</i>	✓	✓	
Follow Digital Velocity Command (link) <i>Unipolar PWM Command</i>	✓	✓	
Follow Digital Velocity Command (link) <i>Frequency Command</i>	✓	✓	
Torque Control Modes	MCVC	MCPV	Description
Follow Digital Torque Command (link) <i>Bipolar PWM Command</i>	✓	✓	ClearPath will apply a variable torque (or force or tension) in proportion to a digital command (PWM or frequency) supplied to the inputs.
Follow Digital Torque Command (link) <i>Unipolar PWM Command</i>	✓	✓	
Follow Digital Torque Command (link) <i>Frequency Command</i>	✓	✓	
Positioning Modes	MCVC	MCPV	Description
Move to Sensor Position (link)	✓	✓	Use ClearPath digital inputs to spin the shaft CW or CCW. Wire your position sensors or switches in series with the inputs to make an inexpensive, precision two position actuator.
Multi-Sensor Positioning: Bi-directional (link) <i>Home to Hard Stop</i>	✗	✓	A trigger pulse starts ClearPath moving in the direction signaled on Input A. When Input B sees a count of transitions equal to the count of trigger pulses, ClearPath will ramp to a stop at the user-defined rate. (These transitions are typically switch closures or sensor interruptions.)

Positioning Modes (cont'd)	MCVC	MCPV	Description
Multi-Sensor Positioning: Unidirectional (link) <i>Sensorless Homing</i>	✘	✔	This mode starts by finding a user-defined, shaft angle home position. Then, upon seeing a transition on Input A, ClearPath will start to move in one, fixed, user-defined direction, at one of two velocities. ClearPath will ramp to a stop at the user-defined rate when Input B has seen a count of transitions equal to the count of transitions on Input A. (These transitions are typically switch closures or sensor interruptions.)
Multi-Sensor Positioning: Unidirectional (link) <i>Home to Sensor</i>	✘	✔	Use simple I/O from your PLC, microcontroller etc. to command ClearPath to move to the sensor or switch of your choosing. Direction, speed, and acceleration are all user-defined in MSP. Optional homing (home-to-sensor) is available.
Move to Absolute Position: 2 Positions (link) <i>Home to Switch</i>	✔	✔	Command ClearPath to move to one of two preset locations. Perfect for replacing air cylinders that move between two positions.
Move to Absolute Position: 4 Positions (link) <i>Home to Hard Stop</i>	✘	✔	Command ClearPath to move to one of four preset locations. Perfect for replacing air cylinders where more power and finesse is needed, and in cases where you want to move to more than two positions.
Move to Absolute Position: 16 Positions (link) <i>Home to Hard Stop</i>	✘	✔	ClearPath will move to one of sixteen user-defined positions when Input A is asserted, depending on the number of times Input B is pulsed. ClearPath can seek for the hard stop home position the first time it is enabled after power up, or each time it is enabled.
Move Incremental Distance: 1 Increment (link) <i>Home to Switch</i>	✘	✔	ClearPath will make an incremental move when the state of Input A changes. If automatic homing is on, ClearPath will seek for the home switch connected to Input B the first time it is enabled after power up, or, if desired, each time it is enabled.
Move Incremental Distance: 2 Increments (link) <i>Home to Switch</i>	✘	✔	Trigger ClearPath to move a user-defined distance (one of two) from its current position. You can also send multiple, quick trigger pulses to tell ClearPath to travel a multiple of any of its user-defined distances in one smooth move.
Move Incremental Distance: 2 Increments (link) <i>Home to Hard Stop</i>	✘	✔	ClearPath will make one of two incremental moves (based on the Input B setting) when Input A changes state. If automatic homing is on, ClearPath will seek for the hard stop home position the first time it is enabled after power up, or, if desired, each time it is enabled.
Move Incremental Distance: 4 Increments (link) <i>Home to Hard Stop</i>	✘	✔	Trigger ClearPath to move a user-defined distance (one of four) from its current position. You can also send multiple, quick trigger pulses to tell ClearPath to travel a multiple of any of its user-defined distances in one smooth move.
Follow Digital Position Command (link) <i>Unipolar PWM Command</i>	✘	✔	ClearPath will servo to a position between two user-defined limits proportional to the PWM duty cycle of the signal on Input B.
Follow Digital Position Command (link) <i>Frequency Command</i>	✘	✔	ClearPath will servo to a position between two user-defined limits based on the frequency of the signal on Input B.
Pulse Burst Positioning (link)	✘	✔	Use a timer/counter on your PLC (or a simple circuit) to send a burst of pulses to ClearPath, and it will move a distance proportional to the number of pulses sent, at your preselected velocity and acceleration. This mode gives you most of the flexibility of a "step & direction" motion controller without the cost and added complexity.

FOLLOW DIGITAL TORQUE COMMAND (BI-POLAR PWM COMMAND)

Available on
MCVC + MCPV

MODE DESCRIPTION

Connect a digital PWM waveform from your PLC or other device, and ClearPath will produce torque proportional to the duty cycle of the PWM waveform.

Assert the Enable Input to energize the motor. Control motor torque by applying a PWM signal to Input B. Motor torque changes in proportion to the duty cycle of the applied PWM signal. Assert the Inhibit signal (Input A) to immediately turn off torque. See figure below and read text for timing and PWM requirements.

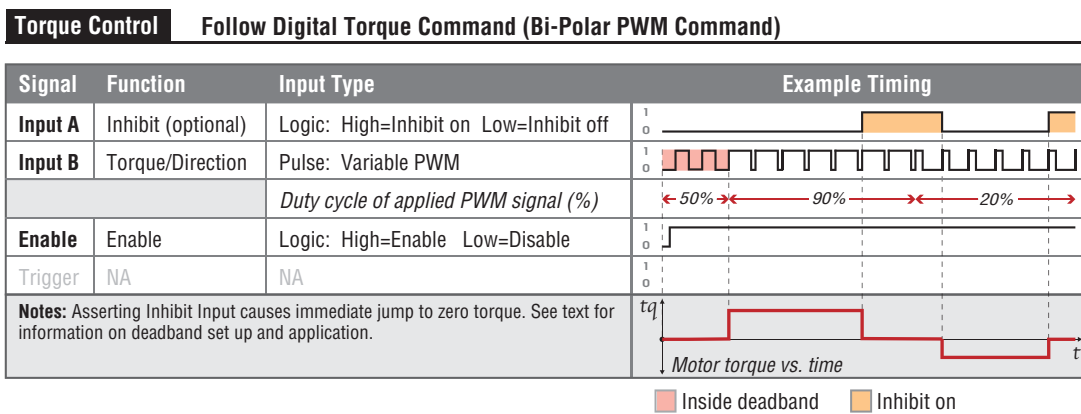

I/O FUNCTIONS

Enable Input - Asserting this input energizes the motor shaft.

Input A - This input forces the torque to zero regardless of the input PWM duty cycle.

Input B - This input is connected to a PWM signal whose duty cycle represents the desired torque.

Output (HLFB) - See HLFb section for available modes.

Notes:

- PWM input frequency range: 20 Hz to 30 kHz.
 - If the PWM signal is off for 50mS (or more) the PWM input is considered off. This is interpreted by ClearPath as a zero-torque command.
 - Disable time = 10 mS

 - To command ClearPath to zero torque, assert the Inhibit): Input (Input A). Deassert Input A to resume normal operation.
- or**
- Set a PWM deadband: to help reliably command zero torque. Refer to text on following pages for details on deadband setup.

MODE CONTROLS

The screenshot shows the Mode Controls interface with the following elements and callouts:

- Max Torque Command (% of max):** A text box containing the value 10. Callout: "Enter max. desired motor torque (i.e., full scale torque)."
- PWM Deadband (+/- %):** A text box containing the value 0. Callout: "Enter deadband setting (optional). See text for description of deadband operation."
- Max Speed (RPM):** A text box containing the value 100.0. Callout: "Enter max. speed limit (ClearPath will shut down if this speed limit is exceeded.)"
- Over-speed Timeout (ms):** A text box containing the value 20. Callout: "Enter value to specify how long ClearPath can spin at **Max Speed** before shutting down."
- Torque Limit:** A section with an "OVR" indicator light and a "Setup..." button. Callout: "Click to open Torque Limit Setup dialog."
- Invert PWM Input:** A checkbox that is currently unchecked. Callout: "Check box to invert how PWM duty cycle is measured by ClearPath." Below this is a legend:
 - NO CHECK:** Duty cycle is % of period high (represented by a high-duty-cycle waveform).
 - CHECK:** Duty cycle is % of period low (represented by a low-duty-cycle waveform).
- Torque Override Indicator:** A callout box stating: "When lit, the main torque limit is being overridden by a secondary, user-set torque limit (e.g., when an axis is homing, the main torque limit may be overridden by the separate homing torque limit setting)."
- Hardware Input Status LEDs:** Callout: "Light = Input asserted (on) Dark = Input de-asserted (off)".
- Inputs and Commands:** A section containing:
 - Enable On/Off:** A light indicator that is currently lit.
 - Input A Inhibit:** A light indicator that is currently dark.
 - Input B Duty Cycle:** A text box displaying "80% Duty Cycle".
 - Torque (% of Peak):** A text box displaying "5.99".
 - ServoOn Output:** A blue button labeled "Servo On".
- Override Inputs:** A checkbox that is currently unchecked. Callout: "Check to turn on Soft Controls. Override cannot be activated when ClearPath is hardware enabled."
- Soft Inputs and LEDs:** Callout: "Emulate hardware inputs. For use only when Soft Controls are active. **Caution: motor may spin when enabled.**"
- PWM Soft Slider:** A slider control. Callout: "Emulates PWM input (for use with Soft Controls)."
- Torque (% of Peak):** A text box displaying "0.". Callout: "Displays commanded torque (when using Soft Controls)."
- ServoOn Output:** Callout: "Displays HILFB output status."

Relationship of PWM duty cycle to motor torque

- Shaft torque increases in the CW direction as PWM duty cycle decreases from 50% to 0%.
- Shaft torque increases in the CCW direction as PWM duty cycle increases from 50% to 100%.
- As PWM duty cycle approaches 50% from either direction, motor torque approaches 0.
- 0% and 100% duty cycle (static low and static high conditions) are not valid PWM states. ClearPath interprets these values as zero-torque commands.
- PWM minimum on time and minimum off time = 300nS.

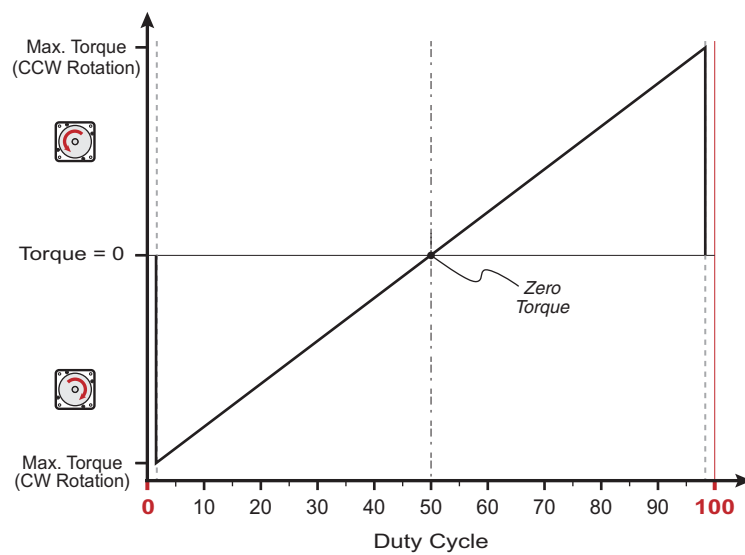

PWM duty cycle vs. motor torque

SETTING A PWM DEADBAND

The deadband expands the range about the 50% PWM mark that is interpreted as the “zero torque setting” by ClearPath. This gives the user a reliable way to ensure that motor torque is completely turned off when the PWM duty cycle is set at (or “close enough” to) 50%.

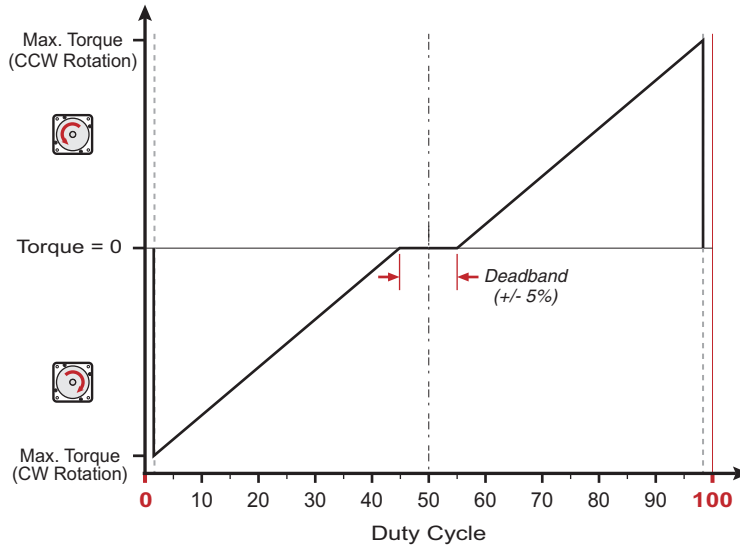

+/- 5% PWM deadband setting

Why use a deadband?

In bi-polar mode, turning off torque is achieved, in theory, by applying a 50% duty cycle PWM signal to Input B. However, it can be difficult to set a perfect 50% duty cycle. In fact, a very small amount of torque may still be produced by the motor, *even when duty cycle is apparently set to 50%*. A deadband helps guarantee torque is fully off when you expect it to be.

Example: If the user sets a +/-5% deadband, any PWM signal with a duty cycle between 45% and 55% (i.e., in the deadband) is interpreted as a zero-torque command by ClearPath.

Note: As deadband setting increases, the slope of torque vs. duty cycle increases as illustrated below.

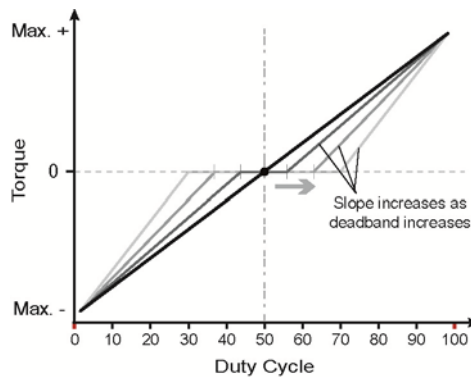

FOLLOW DIGITAL TORQUE COMMAND (UNIPOLAR PWM COMMAND)

Available on
MCVC + MCPV

MODE DESCRIPTION

Connect a digital PWM waveform from your PLC or other device, and ClearPath will generate torque that is proportional to the duty cycle of the PWM waveform.

Assert the Enable Input to energize the motor. Motor torque is controlled by applying a variable PWM signal to Input B. 0% PWM duty cycle commands zero torque, and 100% duty cycle commands full-scale torque. Direction of shaft rotation is controlled by the state of Input A. See Inputs and Timing table below.

Torque Control Variable Torque With Unipolar PWM Input Control

Signal	Function	Input Type	Example Timing
Input A	Direction	Logic: High=CW Low=CCW	
Input B	Torque	Pulse: Variable PWM <i>Duty cycle of applied PWM signal (%)</i>	
Enable	Enable	Logic: High=Enable Low=Disable	
Trigger	NA	NA	
Notes:			

I/O FUNCTIONS

Enable Input - Asserting this input energizes the motor shaft.

Input A - This input selects the direction of the applied torque.

Input B - This input is connected to a PWM signal whose duty cycle represents the desired torque.

Output (HLFB) - See HLFb section for available modes.

Notes:

- PWM input frequency range: 20 Hz to 30 kHz.
- If the PWM signal is off for 50mS (or more) the PWM input is considered off. This is interpreted by ClearPath as a zero-torque command.
- Disable time = 10 mS

MODE CONTROLS

Enter max. torque desired (i.e. full scale torque).

Enter max. speed limit (ClearPath will shut down if this speed limit is exceeded.)

Enter value to specify how long ClearPath can spin at **Max Speed** before shutting down.

Click to open Torque Limit Setup dialog.

Max Torque Command
(% of max)

Max Speed
(RPM)

Over-speed Timeout
(ms)

Torque Limit

OVR [Setup...](#)

Invert PWM Input

Check box to invert how PWM duty cycle is measured by ClearPath.

NO CHECK Duty cycle is % of period high

CHECK Duty cycle is % of period low

Torque Override Indicator

When lit, the main torque limit is being overridden by a secondary, user-set torque limit (e.g., when an axis is homing, the main torque limit may be overridden by the separate homing torque limit setting).

Hardware Input Status LEDs
Light = Input asserted (on)
Dark = Input de-asserted (off)

PWM Meter - Displays duty cycle of PWM source connected to Input B.

Displays commanded torque (when using hard controls).

Inputs and Commands

Override Inputs

Enable On/Off

Input A CW/CCW

Input B Duty Cycle

40% Duty Cycle

Torque (% of Peak)

3.99

0.

ServoOn Output

Servo On

Check to turn on Soft Controls. Override cannot be activated when ClearPath is hardware enabled.

Soft Inputs and LEDs
Emulate hardware inputs. For use only when Soft Controls are active. **Caution: motor may spin when enabled.**

PWM Soft Slider
Emulates PWM input (for use with Soft Controls).

Displays commanded torque (when using Soft Controls).

Displays HILFB output status.

Motor torque vs. PWM duty cycle:

- Motor torque is proportional to PWM duty cycle (i.e. torque increases as duty cycle increases). See figure below.
- 0% and 100% duty cycle signals (static low and static high respectively) are invalid PWM states, interpreted by ClearPath as “PWM turned off”. This is the equivalent of a zero-torque command.

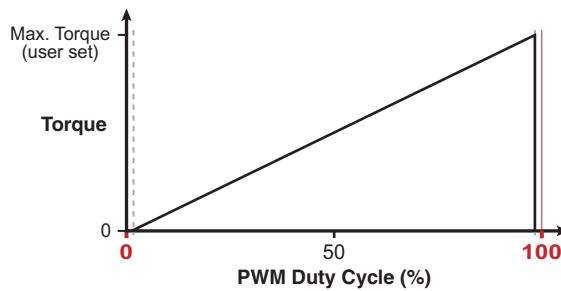

PWM duty cycle vs. torque

- For CW torque, set Input A high. For CCW torque, set Input A low.
- PWM minimum on time and minimum off time = 300nS

FOLLOW DIGITAL TORQUE COMMAND (FREQUENCY COMMAND)

Available on





MCVC + MCPV

MODE DESCRIPTION

Connect a digital variable frequency waveform from your PLC or other device, and ClearPath will produce torque that is proportional to the frequency of the waveform.

Assert the Enable Input to energize the motor. Control torque by applying a variable frequency pulse train to Input B. Pulse frequency is proportional to commanded torque. Direction in which torque is applied (CW/CCW) is controlled by the state of Input A. See Inputs and Timing table below.

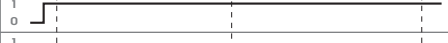
Torque Control Variable Torque With Frequency Input Control

Signal	Function	Input Type	Example Timing
Input A	Direction	Logic: High=CW Low=CCW	
Input B	Torque	Pulse: Variable Frequency	
Enable	Enable	Logic: High=Enable Low=Disable	
Trigger	NA	NA	
Notes:	 <p>Motor torque vs. time</p>		

I/O FUNCTIONS

Enable Input - Asserting this input energizes the motor shaft.

Input A - This input selects the direction of the applied torque.

Input B - This input is connected to a pulse train whose frequency represents the desired torque.

Output (HLFB) - See HLFB section for available modes.

Notes:

- Input frequency range: 20 Hz to 700 kHz.
- If the frequency signal is off for 50mS or more the input is considered off. This is interpreted by ClearPath as a zero-torque command.
- Disable time = 10 mS

MODE CONTROLS

Set Min/Max Frequency. During operation, motor torque is controlled by Input B signal frequency. With settings shown below, a 10 kHz input signal will command the motor to its Max Torque Command (10% of peak), and a signal of 1kHz or less will command zero torque.

Enter max. desired motor torque (i.e., full scale torque).

Enter max. speed limit (ClearPath will shut down if this speed limit is exceeded.)

Enter value to specify how long ClearPath can spin at **Max Speed** before shutting down.

Click to open Torque Limit Setup dialog.

Torque Override Indicator
When lit, the main torque limit is being overridden by a secondary, user-set torque limit (e.g., when an axis is homing, the main torque limit may be overridden by the separate homing torque limit setting).

Hardware Input Status LEDs
Light = Input asserted (on)
Dark = Input de-asserted (off)

Frequency Meter
Displays frequency of signal connected to Input B.

Displays commanded torque (when using hard controls).

Inputs and Commands

Enable On/Off **Input A CW/CCW**

Input B Frequency 1.995 kHz

Torque (% of Peak) 1.11

ServoOn Output Servo On

Override Inputs

Soft Inputs and LEDs
Emulate hardware inputs. For use only when Soft Controls are active. **Caution: motor may spin when enabled.**

PWM Soft Slider
Emulates PWM input (for use with Soft Controls).

Displays commanded torque (when using Soft Controls).

Displays HIFB output status.

RAMP UP/DOWN TO SELECTED VELOCITY

Available on
MCVC + MCPV

MODE DESCRIPTION

Changing the digital inputs on ClearPath (using your PLC, switches, etc.) causes ClearPath to smoothly ramp between any of four user defined velocities.

Assert the Enable Input to get started. Once enabled, ClearPath reads the state of Inputs A and B and immediately accelerates to the target velocity indicated. For example, if **Input A is high** and **Input B is low** ClearPath will ramp to “Velocity 2”. Change to a different velocity by changing Inputs A and B

Velocity Control Ramp Up/Down to Selected Velocity (4 Velocity Programmable)

Signal	Function	Velocity Settings (logic levels)				Example Timing
		Velocity 1	Velocity 2	Velocity 3	Velocity 4	
Input A	Velocity Select A	LOW	HIGH	LOW	HIGH	
Input B	Velocity Select B	LOW	LOW	HIGH	HIGH	
Enable	Enable	Logic: High=Enable Low=Disable				
Trigger	NA	NA				
Tip: Setting one of the programmable velocities to zero (Velocity 3 in the example at right) provides a convenient way to stop the motor via the ClearPath inputs.						

Ramp Up/Down to Selected Velocity Mode: Inputs and Timing Diagram

I/O FUNCTIONS

Enable Input - Asserting this input energizes the motor shaft.

Input A - This input, along with Input B, selects which of the four defined velocities ClearPath will run at.

Input B - This input, along with Input A, selects which of the four defined velocities ClearPath will run at.

Output (HLFB) - See HLFb section for available modes.

Notes:

- As soon as a new velocity command is received by ClearPath—as happens when Inputs A and/or B are changed—ClearPath immediately ramps to the new target velocity without delay.
- For a convenient way to command ClearPath to stop, set one of the velocity settings to zero. We did this with “Velocity 3” in the table above.
- Disable time = 10 mS

MODE CONTROLS

Enter target velocity for each input state here.

Click to open Torque Limit Setup dialog.

Velocity Selection Setup (RPM)

1) A off B off 0.	2) A on B off +10.	3) A off B on +20.	4) A on B on +30.
----------------------	-----------------------	-----------------------	----------------------

Accel (RPM/s)
1,000

Decel = Accel

Decel (RPM/s)
20

Profile Conversion
RAS™ 25 ms
Setup...

Torque Limit

OVR Setup...

Torque Override Indicator
When lit, the main torque limit is being overridden by a secondary, user-set torque limit (e.g., when an axis is homing, the main torque limit may be overridden by the separate homing torque limit setting).

Enter maximum desired motor acceleration rate.

Check here to set motor deceleration rate to same value as acceleration rate.

Enter maximum desired motor deceleration rate..

Adjust settings for RAS™ (or optional g-Stop™) to convert standard trapezoidal move profiles into profiles that reduce noise, resonance, and vibration.

Hardware Input Status LEDs
Light = Input asserted (on)
Dark = Input de-asserted (off)

Displays commanded velocity (when using hard inputs).

Inputs and Commands

	Enable On/Off <input checked="" type="checkbox"/>	Input A V-sel A <input checked="" type="checkbox"/>	Input B V-sel B <input checked="" type="checkbox"/>	Commanded Velocity (RPM) +20.	Servo On Output <input checked="" type="checkbox"/>
<input type="checkbox"/> Override Inputs	<input type="checkbox"/>	<input type="checkbox"/>	<input type="checkbox"/>	0.	

Check to turn on Soft Controls. Override cannot be activated when ClearPath is hardware enabled.

Soft Inputs and LEDs emulate hardware inputs. For use only when Soft Controls are active.
Caution: motor may spin when enabled.

Displays commanded velocity (when using soft inputs).

Displays HLFB output status.

SPIN ON POWER UP

Available on
MCVC + MCPV

MODE DESCRIPTION

This is ClearPath’s simplest mode of operation. Just turn on power and ClearPath smoothly ramps to your preset velocity. Use this mode for applications that require reliable constant velocity and a bare minimum of wiring.

Apply main DC power and ClearPath immediately ramps up to your target velocity (target velocity and acceleration are defined by the user during setup). ClearPath spins at the target velocity until power is removed. All inputs are ignored, but the output (High-Level Feedback) is functional.

Note: When power is removed, ClearPath may stop abruptly or coast a short distance depending on the application and motor winding configuration. Carefully test your loaded ClearPath application for stopping behavior before deploying.

Velocity Control Spin On Power Up

Signal	Function	Input Type	Example Timing
Input A	Disabled	NA	1 0 NA
Input B	Disabled	NA	1 0 NA
Enable	Disabled	NA	1 0 NA
Main Power			ON OFF
Caution! Motor shaft may spin as soon as main power is applied. Notes: All inputs are ignored in this mode. High-Level Feedback is available. Motor will free-wheel when main power is removed, unless external braking force is applied. Motor may stop abruptly depending on load conditions.			<p>Motor velocity vs. time</p>

cc_mcsd

Motor free-wheeling

I/O FUNCTIONS

Enable Input - Not used.

Input A - Not used.

Input B - Not used.

Output (HLFB) - See HLFB section for available modes.

Notes:

- To stop the motor, simply remove power and the motor will stop.
- Other speed modes give you more control of motor behavior, but require a little more wiring. This mode is the simplest way to get constant, servo-controlled motion from a brushless motor."
- Disable time = 10 mS

MODE CONTROLS

Enter target velocity.

Target Velocity (RPM)
+250.

Accel (RPM/s)
1,000

Enter maximum desired motor acceleration rate.

Decel = Accel

Check here to set motor deceleration rate to same value as acceleration rate.

Decel (RPM/s)
50

Enter maximum desired motor deceleration rate.

Profile Conversion
RAS™ 25 ms
Setup...

Adjust settings for RAS™ (or optional g-Stop™) to convert standard trapezoidal move profiles into profiles that reduce noise, resonance, and vibration.

Click to open Torque Limit Setup dialog.

Torque Limit
OVR Setup...

Torque Override Indicator
When lit, the main torque limit is being overridden by a secondary, user-set torque limit (e.g., when an axis is homing, the main torque limit may be overridden by the separate homing torque limit setting).

Displays HLFB output status.

ASG-Velocity Output
At Target Speed

Inputs and Commands
This mode uses no inputs

MANUAL VELOCITY CONTROL

Available on
MCVC + MCPV

MODE DESCRIPTION

This mode offers fine velocity control from zero to a user-defined maximum at the turn of a quadrature output device (such as a quadrature output encoder). Turn in one direction to increase CW motor velocity; turn in the other direction to increase CCW velocity. When enabled, ClearPath can either resume running at its last set speed or start at zero speed (and stay at zero speed until commanded to move).

Assert the Enable Input to energize the motor. Then, control motor velocity by sending quadrature signals to ClearPath Inputs A and B. Each quadrature signal transition (or “tick”) received by ClearPath causes an incremental increase or decrease in motor velocity, depending on which direction the encoder is turned (i.e. whether phase A leads B or B leads A).

Velocity Control Manual Velocity Control

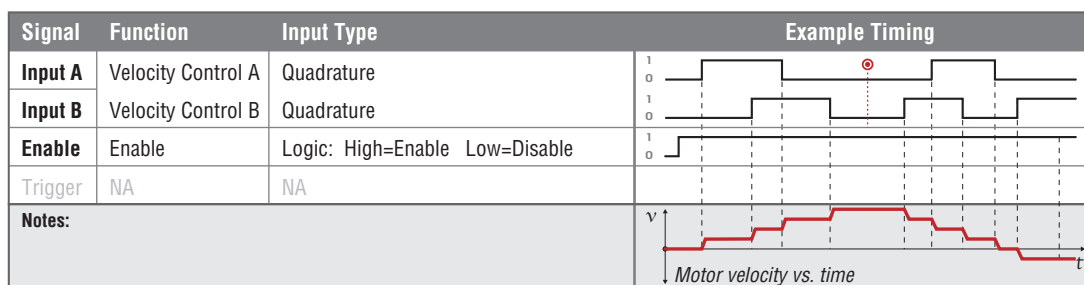

⊙ Knob/encoder rotation reversed

I/O FUNCTIONS

Enable Input - Asserting this input energizes the motor shaft.

Input A - This input is connected to one of the channels of the quadrature output device.

Input B - This input is connected to the other channel of the quadrature output device.

Output (HLFB) - See HLFb section for available modes.

Notes:

- Disable time = 10 mS
- Rotating the quadrature knob in one direction will cause an increase in speed; the other direction causes a decrease (which can be thought of as an increase in the opposite direction).
- If you want to only spin in only one direction, set one of the Max Velocity values in MSP (CW or CCW) to zero.

THE QUADRATURE SIGNAL SOURCE

To use this mode you'll need a quadrature output device (usually an encoder) that can generate two channel (quadrature A/B) signals in the 5-24VDC range. Many users choose an optical or mechanical incremental encoder for this task, but a microcontroller or digital signal generator will work as well.

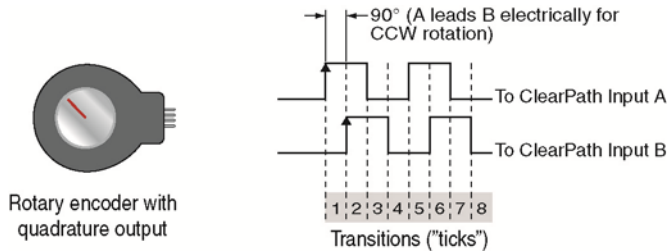

Example: Wiring a Mechanical Quadrature Output Device to ClearPath

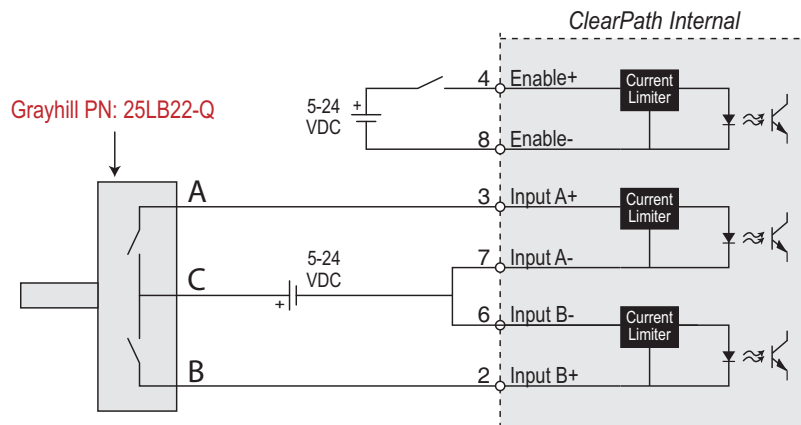
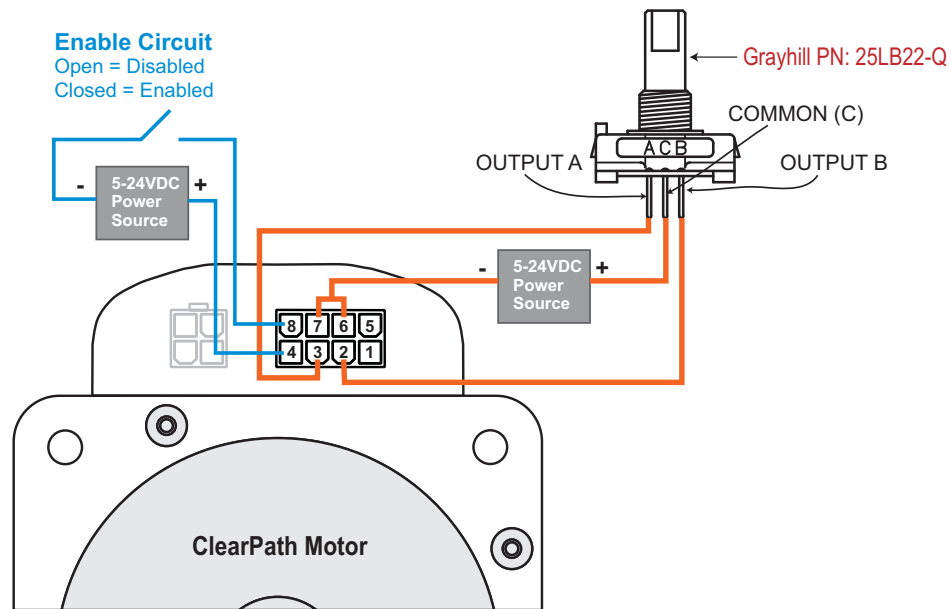

MODE CONTROLS

Encoder Knob Configuration

Enter max. desired motor velocity for CW and CCW shaft rotation.

Enter desired incremental increase / decrease in motor velocity per quadrature tick.

Max CW Velocity (RPM): 700.

Max CCW Velocity (RPM): 1,400.

Velocity Resolution (RPM per knob count): 100.0

Knob Direction: As-Wired

Has Detents

Torque Limit: OVR Setup...

Max Accel (RPM/s): 1,000

Decel = Accel

Max Decel (RPM/s): 100

Profile Conversion: RAS™ 25 ms Setup...

On Enable...: Zero Velocity, Zero Velocity, Last Command

Torque Override Indicator: When lit, the main torque limit is being overridden by a secondary, user-set torque limit (e.g., when an axis is homing, the main torque limit may be overridden by the separate homing torque limit setting).

Hardware Input Status LEDs: Light = Input asserted (on), Dark = Input de-asserted (off)

Inputs and Commands: Enable On/Off, Input A Enc A, Input B Enc B

Commanded Speed (kcnts/sec): 0.00

AllSystemsGo: At Target Speed

Override Inputs

Soft Knob

Click arrows to increase or decrease motor velocity by increment defined in "Velocity Resolution" field above. Each "arrow click" is equivalent to a hardware quadrature "tick"

Click to open Torque Limit Setup dialog.

Reverse sense of motor direction with respect to quadrature phasing, or leave **As-Wired**. Eliminates need to rewire inputs if motor rotates the "wrong" way initially.

See text for description.

Adjust settings for RAS™ (or optional **g-Stop™**) to convert standard trapezoidal move profiles into profiles that reduce noise, resonance, and vibration.

Set motor to initialize to either **Zero Velocity** or **Last Commanded** velocity each time ClearPath is enabled.

Enter maximum desired motor acceleration rate.

Check here to set motor deceleration rate to same value as acceleration rate.

Enter maximum desired motor deceleration rate.

DESCRIPTION OF ENCODER/KNOB SETTINGS

MAX CW VELOCITY

This setting defines the maximum motor shaft velocity that can be reached when the quadrature knob is turned in the direction that causes CW shaft rotation.

MAX CCW VELOCITY

This setting defines the maximum shaft velocity that can be reached when the quadrature knob is turned in the direction that causes CCW shaft rotation.

VELOCITY RESOLUTION

This setting defines exactly how much (i.e., by what increment) motor velocity will increase or decrease per quadrature “tick”.

KNOB DIRECTION

This setting allows the user to reverse the motor’s sense of direction with respect to the quadrature device phasing.

“HAS DETENTS” CHECKBOX

When unchecked, ClearPath treats each quadrature transition it sees as a single “tick”. (Remember, each tick causes an incremental change in motor speed.)

When checked, ClearPath treats every 4th quadrature transition it sees as one “tick”. (Remember, each “tick” causes an incremental change in motor speed.) Check this box when using an encoder that has one detent point per full quadrature cycle or if you want to divide your quadrature resolution by four.

FOLLOW DIGITAL VELOCITY COMMAND (BI-POLAR PWM COMMAND WITH INHIBIT)

Available on
MCVC + MCPV

MODE DESCRIPTION

Connect a digital PWM waveform from your PLC or other device, and ClearPath will run at a velocity proportional to the duty cycle of that waveform. Or, use the PWM output from an H-bridge driver of a brushed motor setup and ClearPath becomes a high-performance drop-in replacement.

Assert the Enable Input to energize the motor. Control motor speed and direction by modulating the duty cycle of the PWM signal. Assert the Inhibit signal (Input A) to immediately ramp to zero velocity. See figure below and read text for timing and PWM requirements.

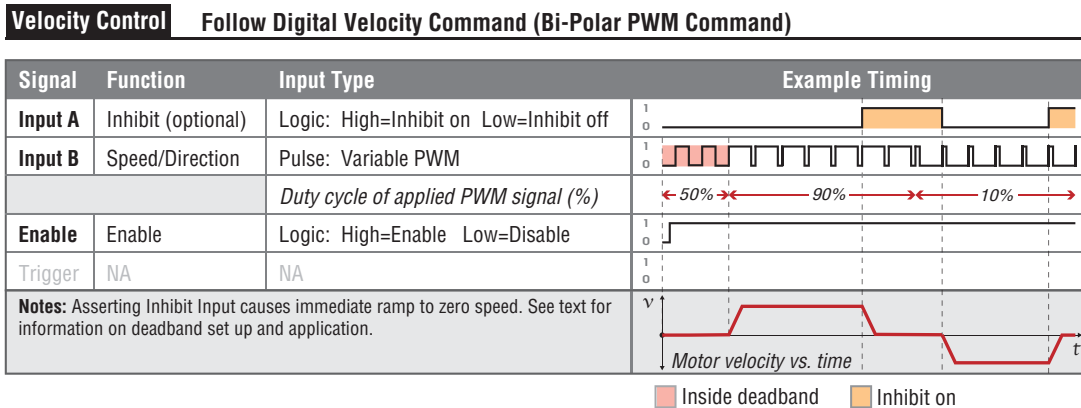

I/O FUNCTIONS

Enable Input - Asserting this input energizes the motor shaft.

Input A - This input forces the speed to zero regardless of the input PWM duty cycle.

Input B - This input is connected to a PWM signal whose duty cycle represents the desired velocity.

Output (HLFB) - See HLFB section for available modes.

Notes:

- PWM input frequency range: 20 Hz up to 30 kHz.
- The output of a standard H-bridge driver for a DC brush motor is bipolar PWM, so it can be used to allow ClearPath to replace a DC brush motor without changing anything else in the system.
- A 50% PWM duty cycle means zero speed; near 100% and near 0% duty cycle correspond to opposite directions at the user-defined maximum speed.
- Input A can be used to command zero speed at any time (overriding the PWM). Or, if duty cycle drift is preventing the

axis from stopping when it should, a deadband can be specified so that any duty cycle that falls within +/- the deadband amount from 50% is considered a command for zero speed.

- If the PWM signal is off for 50mS or more the PWM input is considered off. This is interpreted by ClearPath as a zero-velocity command.
- Disable time = 10 mS
- For applications with the highest sensitivity to velocity accuracy, consider using frequency input control (described later in this manual).

MODE CONTROLS

Enter max. desired motor speed (i.e., full scale speed).

Enter optional deadband setting. See text for description of deadband operation.

Check box to invert how PWM duty cycle is measured by ClearPath.

NO CHECK Duty cycle is % of period high

CHECK Duty cycle is % of period low

Click to open Torque Limit Setup dialog.

Enter maximum desired motor acceleration rate.

Check here to set motor deceleration rate to same value as acceleration rate.

Enter maximum desired motor deceleration rate.

Adjust settings for RAS™ (or optional g-Stop™) to convert standard trapezoidal move profiles into profiles that reduce noise, resonance, and vibration.

Torque Override Indicator
When lit, the main torque limit is being overridden by a secondary, user-set torque limit (e.g., when an axis is homing, the main torque limit may be overridden by the separate homing torque limit setting).

Hardware Input Status LEDs
Light = Input asserted (on)
Dark = Input de-asserted (off)

PWM Meter - Displays duty cycle of PWM source connected to Input B.

Displays commanded velocity (when using hard controls).

Inputs and Commands

Enable On/Off

Input A Inhibit

Input B Duty Cycle 80% Duty Cycle

Commanded Velocity (RPM) 59.0

Servo On Output Servo On

Override Inputs

Soft Inputs and LEDs
Emulate hardware inputs. For use only when Soft Controls are active. **Caution: motor may spin when enabled.**

PWM Soft Slider
Emulates PWM input (for use with Soft Controls).

Displays commanded velocity (when using Soft Controls).

Displays HILFB output status

Relationship of PWM duty cycle to motor velocity

- Shaft velocity increases in the CW direction as PWM duty cycle decreases from 50% to 0%.
- Shaft velocity increases in the CCW direction as PWM duty cycle increases from 50% to 100%.
- As PWM duty cycle approaches 50%—from either direction—motor velocity approaches 0.
- In practice, 0% and 100% (static low and static high conditions) are not valid PWM states. ClearPath treats these cases as zero-velocity commands.
- PWM minimum on time and minimum off time = 300nS.

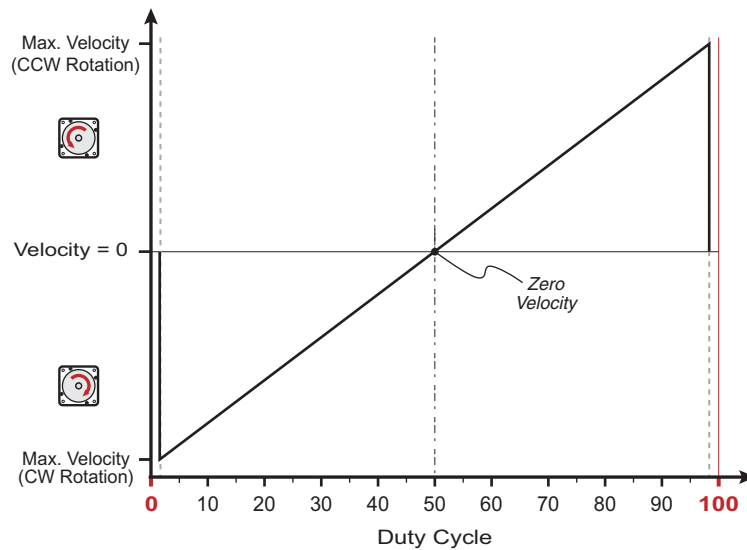

Graph of PWM duty cycle vs. motor velocity

SETTING A PWM DEADBAND (OPTIONAL)

The deadband expands the range about the 50% PWM mark that is interpreted as the “zero-velocity setting” by ClearPath. This gives the user a reliable way to ensure that motor velocity ramps to zero when the PWM duty cycle is set at (or “close enough” to) 50%.

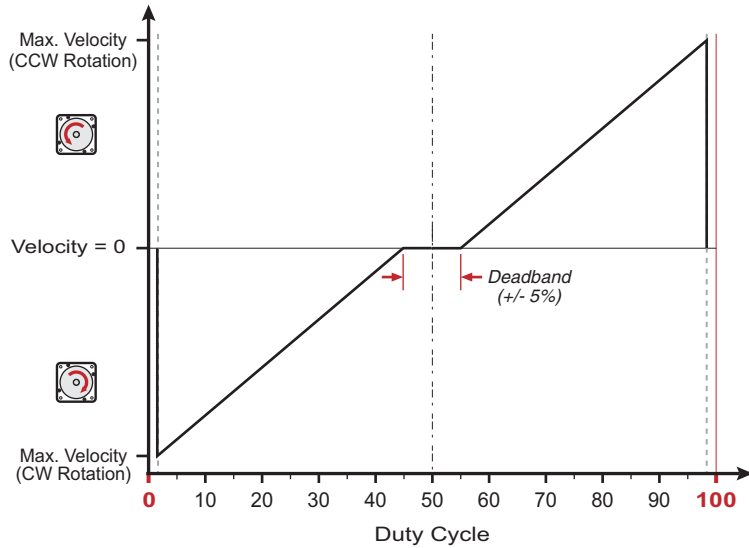

+/- 5% PWM dead band setting

Why use a deadband?

In bi-polar mode, stopping the motor (i.e. commanding “zero velocity”) is achieved, in theory, by applying a 50% duty cycle PWM signal to Input B. However, it can be technically challenging to set a perfect 50% duty cycle. In fact, some very low speed motion may still be observed at the motor shaft *even when duty cycle is apparently set to 50%*. A deadband helps to ensure that actual motor velocity is zero (with no drift) when you expect it to be.

Example: If the user sets a +/- 5% dead band, any PWM signal with a duty cycle between 45% and 55% will be interpreted as a zero-velocity command by ClearPath. See figure above.

Note: As size of deadband setting increases, the slope of velocity vs. duty cycle increases as illustrated below.

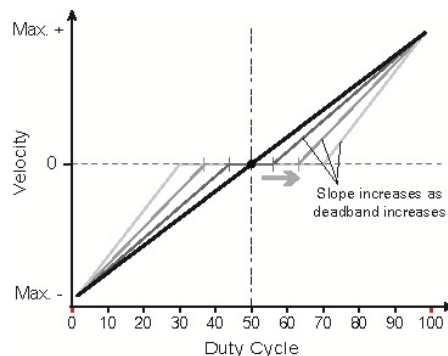

FOLLOW DIGITAL VELOCITY (BIPOLAR PWM COMMAND WITH VARIABLE TORQUE)

Available on
MVC + MCPV

MODE DESCRIPTION

Control velocity and maximum torque independently and concurrently with this mode. Connect a digital PWM waveform from your PLC or other device to Input B, and ClearPath will run at a velocity proportional to the duty cycle of that waveform. Connect a separate digital or PWM signal to Input A to independently vary your motor's torque limit.

I/O FUNCTIONS

Enable Input - Asserting this input energizes the motor shaft.

Input A - This input is connected to a signal whose level or PWM duty cycle represents the desired torque limit.

Input B - This input is connected to a PWM signal whose duty cycle represents the desired velocity.

Output (HLFB) - See HLFb section for available modes.

Assert the Enable Input to energize the motor.

Velocity Control (Input B). Motor velocity is controlled by sending a PWM signal to Input B. Velocity is commanded as follows:

- Shaft velocity increases in the CW direction as PWM duty cycle decreases from 50% to 0%.
- Shaft velocity increases in the CCW direction as PWM duty cycle increases from 50% to 100%.
- As PWM duty cycle approaches 50%—from either side—motor velocity approaches 0.
- In practice, 0% and 100% (static low and static high conditions) are not valid PWM states. ClearPath treats these cases as zero-velocity commands.
- All changes in velocity occur at the user-defined acceleration rate.
- Set a PWM deadband to help reliably command zero velocity.
- PWM minimum on time and minimum off time = 300nS.

Torque Limit Control (Input A). Vary your motor's maximum torque between the "standard" Torque Limits and the Alternate Torque Limits using either digital or PWM control methods.

For **digital torque limit control**, toggle between the Torque Limits and Alternate Torque Limits by changing the state of Input A as follows:

- Deassert input A to operate using purely the "standard" Torque Limits.

- Assert input A to operate using purely the Alternate Torque Limits.

For **PWM torque limit control**, you can vary the active torque limit linearly between the two torque limit settings by varying the PWM duty cycle sent to Input A as follows:

- Apply a 0% duty cycle (static low) to operate using purely the "standard" Torque Limits.
- Apply a 100% duty cycle (static high) to operate using purely the Alternative Torque Limits.
- Apply a duty cycle anywhere in between 0% and 100% to create a linear combination of the two limits.

Additional Notes:

- PWM input frequency range: 20 Hz up to 30 kHz.
- If the PWM signal is off for 50mS or more the PWM input is considered off.
- Disable time = 10 mS.

MODE CONTROLS

Max Speed (RPM)
1,000

Enter max. desired motor speed (i.e., full scale speed).

PWM Deadband (+/-%)
0

Enter optional deadband setting. See text for description of deadband operation.

Relax Time (ms)
50.

Enter timespan over which changes made to torque limit occur.

Torque Limit OVR Setup...

Torque Override Indicator
When lit, the main torque limit is being overridden by a secondary, user-set torque limit (e.g., when an axis is homing, the main torque limit may be overridden by the separate homing torque limit setting).

Active Torque Limits (% of Max)
-23.4 to +23.4

Displays torque limit values that are currently in effect.

Max Accel (RPM/s)
5,000

Enter maximum desired motor acceleration rate.

Decel = Accel

Check here to set motor deceleration rate to same value as acceleration rate.

Max Decel (RPM/s)
500

Enter maximum desired motor deceleration rate..

Profile Conversion
RAS™ 25 ms
Setup...

Adjust settings for RAS™ (or optional g-Stop™) to convert standard trapezoidal move profiles into profiles that reduce noise, resonance, and vibration.

Click to open Torque Limit Setup dialog.

Invert Torque PWM Input
 Invert Speed PWM Input

Check box to invert how PWM duty cycle is measured by ClearPath.

NO CHECK

Duty cycle is % of period high

CHECK

Duty cycle is % of period low

Hardware Enable Status LED
Light = Input asserted (on)
Dark = Input de-asserted (off)

PWM Meter (Torque Limiting)
Displays duty cycle of PWM signal connected to Input A.

PWM Meter (Velocity)
Displays duty cycle of PWM signal connected to Input B.

Displays commanded velocity (when using hard controls).

Inputs and Commands

Override Inputs

Enable On/Off

Input A Torque Limiting
No PWM

Input B Velocity
80% Duty Cycle

Cmd. Velocity (RPM)
590

Servo On Output
Servo On

Check to turn on Soft Controls. Override cannot be activated when ClearPath is hardware enabled.

Soft Enable Control
Check to enable. For use only when Soft Controls are active. **Caution: motor may spin when enabled.**

Input A PWM Soft Slider
Emulates PWM input (for use with Soft Controls).

Input B PWM Soft Slider
Emulates PWM input (for use with Soft Controls).

Displays commanded velocity (when using Soft Controls).

Displays HLFB output status

FOLLOW DIGITAL VELOCITY COMMAND (UNIPOLAR PWM INPUT)

Available on

MVC + MCPV

MODE DESCRIPTION

Connect a digital PWM waveform from your PLC or other device, and ClearPath will run at a speed proportional to the duty cycle of the PWM waveform.

Assert the Enable Input to energize the motor. Once enabled, motor velocity is controlled by sending a PWM signal to Input B. 0% PWM duty cycle commands zero velocity, and 100% (minus a little) duty cycle commands full-scale velocity. Changes in velocity occur at the user-defined acceleration rate.

Direction of travel (CW/CCW) is controlled by the state of Input A. See Inputs and Timing table below.

Velocity Control Follow Digital Velocity Command (Unipolar PWM Command)

Signal	Function	Input Type	Example Timing
Input A	Direction	Logic: High=CW Low=CCW	
Input B	Velocity	Pulse: Variable PWM	
		<i>Duty cycle of applied PWM signal (%)</i>	
Enable	Enable	Logic: High=Enable Low=Disable	
Trigger	NA	NA	
Notes:			<p><i>Motor velocity vs. time</i></p>

I/O FUNCTIONS

Enable Input - Asserting this input energizes the motor shaft.

Input A - This input selects the direction of rotation.

Input B - This input is connected to a PWM signal whose duty cycle represents the desired speed.

Output (HLFB) - See HLFB section for available modes.

Notes:

- PWM input frequency range: 20 Hz up to 30 kHz.
- If the PWM signal is off for 50mS or more the PWM input is considered off. This is interpreted by ClearPath as a zero-velocity command.
- Disable time = 10 mS
- For applications with the highest sensitivity to velocity accuracy, consider using frequency input control (described in next section).

MODE CONTROLS

Enter max. desired motor speed (i.e., full scale speed).

Enter maximum desired motor acceleration rate.

Check here to set motor deceleration rate to same value as acceleration rate.

Enter maximum desired motor deceleration rate..

Adjust settings for RAS™ (or optional g-Stop™) to convert standard trapezoidal move profiles into profiles that reduce noise, resonance, and vibration.

Click to open Torque Limit Setup dialog.

Torque Override Indicator
When lit, the main torque limit is being overridden by a secondary, user-set torque limit (e.g., when an axis is homing, the main torque limit may be overridden by the separate homing torque limit setting).

Hardware Input Status LEDs
Light = Input asserted (on)
Dark = Input de-asserted (off)

PWM Meter - Displays duty cycle of PWM source connected to Input B.

Displays commanded velocity (when using hard controls).

Inputs and Commands

Enable On/Off

Input A CW/CCW

Input B Duty Cycle
50% Duty Cycle

Commanded Velocity (RPM)
1,001

Servo On Output
Servo On

Override Inputs

Check to turn on Soft Controls. Override cannot be activated when ClearPath is hardware enabled.

Soft Inputs and LEDs
Emulate hardware inputs. For use only when Soft Controls are active. **Caution: motor may spin when enabled.**

PWM Soft Slider
Emulates PWM input (for use with Soft Controls).

Displays commanded velocity (when using Soft Controls).

Displays HILFB output status.

Motor velocity vs. PWM duty cycle :

- Motor velocity is proportional to PWM duty cycle (velocity increases as duty cycle increases). See figure below.
- In practice, 0% and 100% duty cycle signals (static low and static high respectively) are invalid PWM states, interpreted by ClearPath as “PWM turned off”. This is the equivalent of a zero-velocity command.

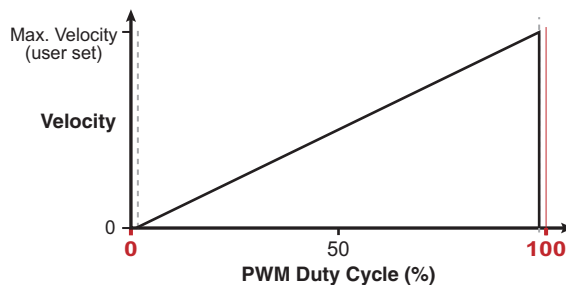

- For CW shaft rotation, set Input A high. For CCW shaft rotation, set Input A low.
- PWM minimum on time and minimum off time = 300nS

FOLLOW DIGITAL VELOCITY COMMAND (FREQUENCY INPUT)

Available on

MCVC + MCPV

MODE DESCRIPTION

Connect a digital variable frequency waveform from your PLC or other device, and ClearPath will run at a velocity proportional to the frequency of the waveform.

Assert the Enable Input to energize the motor. Then, control velocity by applying a variable frequency pulse train to Input B. Pulse frequency is proportional to commanded velocity. Direction of travel (CW/CCW) is controlled by the state of Input A. See Inputs and Timing diagram below.

Velocity Control Follow Digital Velocity Command (Frequency Input Control)

Signal	Function	Input Type	Example Timing
Input A	Direction	Logic: High=CW Low=CCW	
Input B	Velocity	Pulse: Variable Frequency	
Enable	Enable	Logic: High=Enable Low=Disable	
Trigger	NA	NA	
Notes:			

I/O FUNCTIONS

Enable Input - Asserting this input energizes the motor shaft.

Input A - This input selects the direction of rotation.

Input B - This input is connected to a pulse train whose frequency represents the desired speed.

Output (HLFB) - See HLFb section for available modes.

Notes:

- Input frequency range: 20 Hz to 700 kHz.
- Actual motor speed in RPM is given by the following equation $[(\text{Input Freq.} - \text{Min Freq.}) / (\text{Max Freq.} - \text{Min Freq.}) * \text{User Defined Max Velocity}]$. For **Example**, a 120 kHz pulse train with 100 kHz Min Frequency and 200 kHz Max frequency will result in a rotational speed of 20% of the user-defined Max Velocity.
- If the frequency signal is off/interrupted for 50mS or more the input is considered off. This is interpreted by ClearPath as a zero-velocity command.
- Disable time = 10 mS

MODE CONTROLS

Set Min/Max Frequency. During operation, motor speed is controlled by Input B signal frequency. With the settings below, a 15kHz signal at Input B will cause the motor to spin at the Max Speed setting (2000 RPM); a 5 kHz (or lower) signal will command zero speed.

Enter max. desired motor speed (i.e., full scale speed).

Enter maximum desired motor acceleration rate.

Check here to set motor deceleration rate to same value as acceleration rate.

Enter maximum desired motor deceleration rate..

Adjust settings for RAS™ (or optional g-Stop™) to convert standard trapezoidal move profiles into profiles that reduce noise, resonance, and vibration.

Click to open Torque Limit Setup dialog.

Torque Override Indicator
When lit, the main torque limit is being overridden by a secondary, user-set torque limit (e.g., when an axis is homing, the main torque limit may be overridden by the separate homing torque limit setting).

Hardware Input Status LEDs
Light = Input asserted (on)
Dark = Input de-asserted (off)

Frequency Meter
Displays frequency of input signal source connected to Input B.

Displays commanded velocity (when using hard controls).

Inputs and Commands

Enable On/Off

Input A CW/CCW

Input B Frequency

Commanded Velocity (RPM)

Servo On Output

Override Inputs

Soft Inputs and LEDs
Emulate hardware inputs. For use only when Soft Controls are active. **Caution: motor may spin when enabled.**

Frequency Soft Slider
Emulates frequency input source (for use with Soft Controls).

Displays commanded velocity (when using Soft Controls).

Displays HLFB output status.

MOVE TO SENSOR POSITION

Available on
MVCV + MCPV

MODE DESCRIPTION

This mode is mainly intended to be used in two-position back and forth applications (like replacing a pneumatic cylinder). Use ClearPath digital inputs to spin the shaft CW or CCW. Wire position sensors or switches in series with ClearPath inputs to make an inexpensive two position actuator.

Place sensors at opposite ends of your motion path and wire them into the appropriate ClearPath inputs. See illustration below.

Assert the Enable Input to energize the motor. Apply User Commands to start motion. ClearPath moves CW or CCW until it interrupts a sensor. It then holds position until you issue a new User Command in the opposing direction. See table below for Input states and timing details.

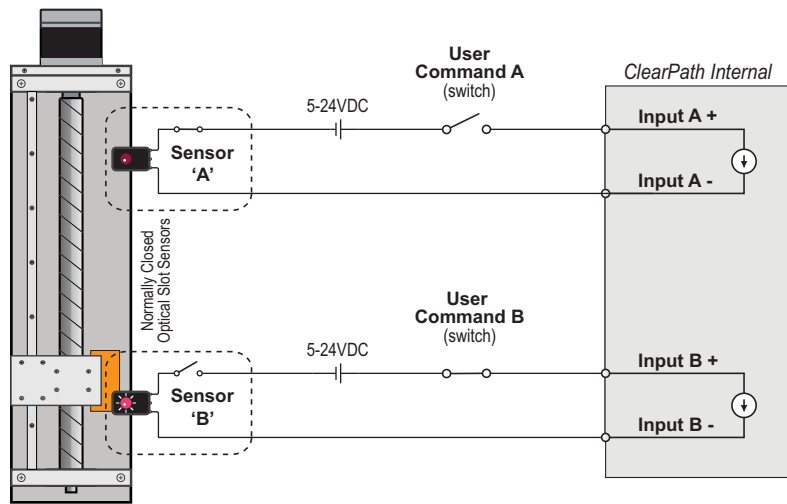
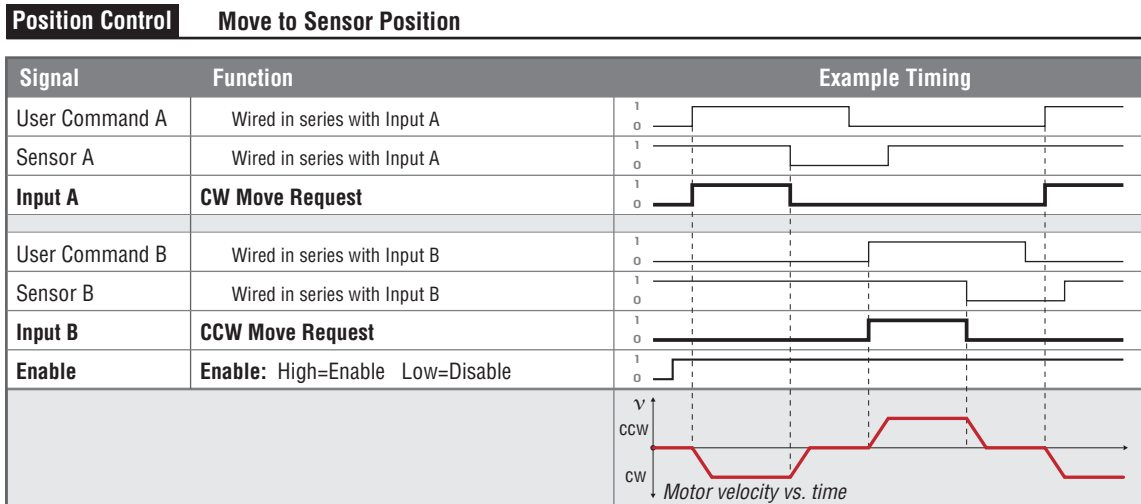

Move to Sensor: Inputs and Timing Diagram with example application sketch

I/O FUNCTIONS

Enable Input - Asserting this input energizes the motor shaft.

Input A - This input is used to make the motor spin in the CW (clockwise) direction.

Input B - This input is used to make the motor spin in the CCW (counterclockwise) direction.

Output (HLFB) - See HLFB section for available modes.

Notes:

- Position sensors (switches) are used to set the stopping points.
- In the typical application, the switch that detects the end of CW travel is wired in series with Input A so that the command to move is interrupted and the motor stops at the desired location. The CCW switch is similarly wired in series with Input B.
- CCW (counterclockwise) and CW (clockwise) are defined when you view the motor with the shaft pointing toward you.
- When a switch interrupts the move input, the motor will begin to decelerate, so the stopped position will be a repeatable distance beyond the switch. Make sure you leave enough room after the sensor to avoid hitting the end stops.
- ClearPath will not allow two successive moves in the same direction, so you don't have to worry about the motor moving past the switch as it decelerates (and thereby re-asserting the move input).
- Changing the state of either Input A or Input B while ClearPath is in motion effectively cancels the move in progress. ClearPath immediately ramps to a stop and holds position until a new move request³ is received.
- Disable time = 10 mS

³ In this scenario, the next move request must be in the opposite direction from the previous move request. Thus, if the motor was spinning in the CW direction when the move was canceled, ClearPath will only respond to a CCW move request.

MODE CONTROLS

Enter max velocity desired for CW rotation.

Enter max velocity desired for CCW rotation.

Click to open Torque Limit Setup dialog.

CW Vel Limit (RPM)
200.

CCW Vel Limit (RPM)
200.

Torque Limit
OVR Setup...

Accel (RPM/s)
5,000

Decel = Accel

Decel (RPM/s)
5,000

Profile Conversion
g-Stop™ 62 ms
Setup...

Torque Override Indicator
When lit, the main torque limit is being overridden by a secondary, user-set torque limit (e.g., when an axis is homing, the main torque limit may be overridden by the separate homing torque limit setting).

Enter desired motor acceleration rate.

Check here to set motor deceleration rate to same value as acceleration rate.

Enter desired motor deceleration rate.

Adjust settings for **RAS™** (or optional **g-Stop™**) to convert standard trapezoidal move profiles into profiles that reduce noise, resonance, and vibration.

Hardware Input Status LEDs
Light = Input asserted (on)
Dark = Input de-asserted (off)

Inputs and Commands

Enable On/Off

Input A CW Request

Input B CCW Request

ServoOn Output
Servo On

Override Inputs

Check to turn on Soft Controls. Override cannot be activated when ClearPath is hardware enabled.

Soft Inputs and LEDs emulate hardware inputs. For use only when Soft Controls are active.
Caution: motor may spin when enabled.

Displays HLFB output status.

MOVE TO ABSOLUTE POSITION (2-POSITION, HOME TO SWITCH)

Available on
MCVC + MCPV

MODE DESCRIPTION

Trigger ClearPath to move to one of two preset locations. This mode was designed for replacing hydraulic or pneumatic cylinders that move between two positions.

Assert the Enable Input to energize the motor. Once enabled, ClearPath automatically executes a homing move to a [user-supplied] switch or sensor wired to Input B. Once a home position is established, ClearPath automatically moves to one of the two user-defined positions (based on the state of Input A). After that, just toggle Input A to move between the two target positions.

Absolute Position

An absolute position is referenced to an established “home” position. Your target positions, in this context, are defined in terms of *distance from the home position*. For example, Position 1 could be defined as 5200 encoder counts from home, while Position 2 might be defined as 2000 encoder counts from home.

Position Control Absolute Position (2-Position Programmable)

Signal	Function	Input Type	Example Timing
Input A	Position Select	Logic: High=Pos. 2 Low=Pos. 1	<p>The timing diagram shows four digital signals: Input A, Input B, Enable, and Trigger. Input A is a square wave that alternates between high and low. Input B is a pulse that goes high once. Enable is a pulse that goes high and stays high. Trigger is a pulse that goes high once. The motor position vs. time graph shows the motor starting at a low position, moving to a 'Home' position (zero), then moving to 'Pos 1' when Input A is high, and moving to 'Pos 2' when Input A is low. This sequence repeats.</p>
Input B	Home Switch	Logic: High=Home Low= Not Home	
Enable	Enable	Logic: High=Enable Low=Disable	
Trigger	NA	NA	
Notes: ClearPath must home to a switch upon enable to establish the Home (zero) position to which the other target positions are referenced.			

I/O FUNCTIONS

Enable Input - Asserting this input energizes the motor shaft.

Input A - This input selects one of two user-defined positions to which the motor should move.

Input B - This input is connected to the home switch. Its function is defined in the homing setup dialog.

Output (HLFB) - See HLFB section for available modes.

Notes:

- If the state of Input A is changed during a move, ClearPath will immediately ramp to a stop and move to the newly indicated position.

- The user-defined positions can be 'taught' instead of entered numerically through MSP. To do this, the motor must be in a Logic Backup Power (LBP) state (using a ClearPath POWER4-HUB board). The main bus power must be off. **To teach a position**, deassert the Enable input with the motor in the position you want to teach (or deassert the Enable and then move the axis by hand to the desired spot). Set input A to the binary state you want to teach, and assert the Enable input. The current location will then be linked to the current input A state. Deassert Enable and repeat as desired with the other A state.
- Input B switch polarity can be inverted via a checkbox in the Homing Setup dialog. When home switch polarity is inverted, ClearPath interprets Input B-low as “in the home switch”, and Input B-high as “not in the home switch”.
- Disable time = 10 mS

MODE CONTROLS

Set Target Positions
Enter move distance (from home) for each input state.

Position Selection	Setup (cnts)
1) A off <input style="width: 80%;" type="text" value="+10,000"/>	2) A on <input style="width: 80%;" type="text" value="+100,000"/>

Click to open Torque Limit Setup dialog. Click to open Homing Setup dialog.

Torque Limit

OVR

Homing

Speed Limit (RPM)

Enter max. desired motor speed.

Accel (RPM/s)

Enter max. desired acceleration rate.

Profile Conversion

Adjust settings for RAS™ (or optional **g-Stop™**) to convert standard trapezoidal move profiles into profiles that reduce noise, resonance, and vibration.

Enable Teaching

Enable teaching mode.
This allows the user to physically move a motor to a desired target position and save that position to the motor's memory (as opposed to keying in numerical values).

Hardware Input Status LEDs
Light = Input asserted (on)
Dark = Input de-asserted (off)

Inputs and Commands	Enable On/Off	Input A Position	Input B Home Switch	ServoOn Output
<input type="checkbox"/> <input type="checkbox"/>	<input checked="" type="checkbox"/>	<input checked="" type="checkbox"/>	<input checked="" type="checkbox"/>	<input type="button" value="Servo On"/>
<input type="checkbox"/> <input type="checkbox"/>	<input type="checkbox"/>	<input type="checkbox"/>	<input type="checkbox"/>	

Override Inputs
Check to turn on Soft Controls. Override cannot be activated when ClearPath is hardware enabled.

Soft Inputs and LEDs emulate hardware inputs. For use only when Soft Controls are active.
Caution: motor may spin when enabled.

Displays HILFB output status.

MOVE TO ABSOLUTE POSITION (4-POSITION, HOME TO HARD STOP)

Available on

MCPV

MODE DESCRIPTION

Command ClearPath to move to one of four preset locations. Perfect for replacing air cylinders in scenarios where more power and/or finesse are needed (and you want to position at more than just two locations).

Absolute Position

An absolute position is referenced to an established “home” position. Your target positions, in this context, are defined in terms of *distance from the home position*. For example, Position 1 might be defined as 2000 encoder counts from home, while Position 2 might be defined as 5200 encoder counts from home.

Assert the Enable Input to energize the motor. Once enabled ClearPath automatically homes to a hard stop to establish an absolute home reference position. Note: Homing is required in this mode.

After homing, ClearPath can be commanded to move to any of four user-defined positions by changing the state of Input A and B. Changing these inputs has the dual effect of selecting target position, and triggering the move. See table below for timing and input details. All moves execute at the user-defined speed and acceleration.

Position Control Absolute Positioning (4-Position Programmable)

Signal	Function	Position Settings				Example Timing
		Pos. 1	Pos. 2	Pos. 3	Pos. 4	
Input A	Position Select A	LOW	HIGH	LOW	HIGH	
Input B	Position Select B	LOW	LOW	HIGH	HIGH	
Enable	Enable	Logic: High=Enable Low=Disable				
Trigger	NA	NA				
Notes: ClearPath must home to a “hard stop” (either upon first enable or upon every enable) to establish a home reference position. All user-defined target positions are referenced to the home position.						

I/O FUNCTIONS

Enable Input - Asserting this input energizes the motor shaft.

Input A - This input, along with Input B, selects one of four user-defined positions to which the motor should move.

Input B - This input, along with Input A, selects one of four user-defined positions to which the motor should move.

Output (HLFB) - See HLFB section for available modes.

Notes:

- If Input A or B changes while the ClearPath is moving, the behavior will depend on the new move target. If the new move

target is in the same direction as the current motion, the move will continue until the new target location is reached. If the new move target is in the opposite direction of current motion, the move will decelerate to a stop and then immediately begin the move to the new target location.

- The user-defined positions can be 'taught' instead of entered numerically through MSP. To do this, the motor must be in a Logic Power Backup (LPB) state (using a ClearPath POWER4-HUB board). The main bus power must be off.
- **To teach a position**, deassert the Enable input with the motor in the position you want to teach (or deassert the Enable and then move the axis by hand to the desired spot). Set inputs A and B to the binary state you want to teach, and assert the Enable input. The current location will then be linked to the current input A/B state. Deassert Enable and repeat as desired with other A/B states.
- Changing the state of Input A and/or B while ClearPath is in motion cancels the move in progress. ClearPath immediately ramps to a stop and initiates a new move to the newly indicated target position.
- Disable time = 10 mS

MODE CONTROLS

Position Selection Setup (cnts)

1) A off B off	2) A on B off	3) A off B on	4) A on B on
-23,699	-27,965	-47,156	-65,349

Speed Limit (RPM)
800.

Accel (RPM/s)
25,000

Profile Conversion
RAS™ 44 ms
Setup...

Torque Limit
Setup...

Homing
Setup...

Enable Teaching
 ?

Hardware Input Status LEDs
Light = Input asserted (on)
Dark = Input de-asserted (off)

Inputs and Commands	Enable On/Off	Input A P-sel A	Input B P-sel B	ServoOn Output
<input type="checkbox"/> Override Inputs	<input checked="" type="checkbox"/>	<input checked="" type="checkbox"/>	<input checked="" type="checkbox"/>	Servo On
	<input type="checkbox"/>	<input type="checkbox"/>	<input type="checkbox"/>	Set Home Posn

Set Target Positions
Enter move distance (from home) for each input state.

Click to open Torque Limit Setup dialog.

Click to open Homing Setup dialog.

Enter max. desired motor speed.

Enter max. desired acceleration rate.

Adjust settings for RAS™ (or optional g-Stop™) to convert standard trapezoidal move profiles into profiles that reduce noise, resonance, and vibration.

Torque Override Indicator
When lit, the main torque limit is being overridden by a secondary, user-set torque limit (e.g., when an axis is homing, the main torque limit may be overridden by the separate homing torque limit setting).

Enable teaching mode.
This allows the user to physically move a motor to a desired target position and save that position to the motor's memory (as opposed to keying in numerical values by hand).

Check to turn on Soft Controls. Override cannot be activated when ClearPath is hardware enabled.

Soft Inputs and LEDs emulate hardware inputs. For use only when Soft Controls are active. Caution: motor may spin when enabled.

Click during homing operation to manually set home position.

Displays HILFB output status.

MOVE TO ABSOLUTE POSITION (16-POSITION, HOME TO HARD STOP)

Available on

MCPV

MODE DESCRIPTION

Command ClearPath to move to one of 16 preset positions by toggling Input B (between 1 and 16 times) to specify a target position [position index]. then toggle input A to trigger the move.

Absolute Position

An absolute position is referenced to an established “home” position. Your target positions, in this context, are defined in terms of *distance from the home position*. For example, Position 1 might be defined as 1000 encoder counts from home, while Position 2 might be defined as 2000 encoder counts from home, and so forth

Assert the Enable Input to energize the motor. Once enabled, ClearPath must be homed to a known position.

To make a move, first send between 1 and 16 pulses to Input B (this tells ClearPath which target position to move to). Then toggle Input A to trigger the move. Example: to move to target position 9, you would send 9 pulses to input B. Then you would trigger the move by sending a single pulse to Input A. ClearPath would then move to position 9 at the user-defined speed and acceleration.

Position Control Absolute Positioning (16 Positions, HS Home)

Signal	Function	Input Type	Example Timing
Input A	Trigger	Pulse to start move (on rising-edge)	
Input B	Position Select	Pulse input to select target position	
Enable	Enable	Logic: High=Enable Low=Disable	
Notes: ClearPath must be homed to use this mode (see text for details).			

I/O FUNCTIONS

Enable Input - Asserting this input energizes the motor shaft.

Input A - This input triggers the motor to move to one of sixteen user-selected positions.

Input B - Pulse (assert then deassert) this input 1-16 times to select which of sixteen user-defined positions the motor will move to when Input A is asserted.

Output (HLFB) - See HLFb section for available modes.

Notes:

- While Input A is asserted pulses on Input B will be ignored and the motor will remain at its current position.

- Deasserting Input A resets the position selection index to 0.
- Asserting Input A (to move) after pulsing Input B more than 16 times generates a shutdown because an invalid index was selected. The shutdown can be cleared by toggling the Enable input.
- An executing move can be superseded by sending a new move index number command.
- Disable time = 10mS

MODE CONTROLS

Set Target Positions
Enter move distance (from home) for each index position.

Torque Override Indicator
When lit, the main torque limit is being overridden by a secondary, user-set torque limit (e.g., when an axis is homing, the main torque limit may be overridden by the separate homing torque limit setting).

Click to open Torque Limit Setup dialog.

Click to open Homing Setup dialog.

Position Selection Setup (cnts)

1) +10,000	2) +20,000	3) +30,000	4) +40,000
5) +50,000	6) +60,000	7) +70,000	8) +80,000
9) +90,000	10) +100,000	11) +110,000	12) +120,000
3) +130,000	14) +140,000	15) +150,000	16) +160,000

Torque Limit

OVR Setup...

Speed Limit (RPM)

800.

Accel (RPM/s)

25,000

Profile Conversion

RAS™ 44 ms

Setup...

Enter max. desired motor speed.

Enter max. desired acceleration rate.

Adjust settings for RAS™ (or optional g-Stop™) to convert standard trapezoidal move profiles into profiles that reduce noise, resonance, and vibration.

Hardware Input Status LEDs
Light = Input asserted (on)
Dark = Input de-asserted (off)

Displays the current Position Index number (5 in this example) and its associated encoder position. A trigger event on Input A will launch a move to this position (and reset the Index).

Inputs and Commands

Override Inputs

Enable On/Off

Input A Trigger

Input B Index

Position Index

5: +50,000

Set Home Posn

ServoOn Output

Servo On

Check to turn on Soft Controls. Override cannot be activated when ClearPath is hardware enabled.

Soft Inputs and LEDs emulate hardware inputs. For use only when Soft Controls are active.
Caution: motor may spin when enabled.

Click during homing operation to manually simulate home position.

Displays HLFB output status.

MOVE INCREMENTAL DISTANCE (4-DISTANCE, HOME TO HARD STOP)

Available on

MCPV

MODE DESCRIPTION

Send a trigger pulse to tell ClearPath to move a user-defined distance [increment] from its current position. Send multiple, quick trigger pulses to tell ClearPath to travel a multiple of any distance in one smooth, uninterrupted move.

Incremental Positioning

An incremental move is referenced to its own starting position, not to an absolute “home” reference position. So, if the incremental move distance is set to +1000 counts, the shaft will move +1000 counts from its current position each time a trigger pulse is received.

Assert the Enable Input to energize the motor. ClearPath can be set to perform an optional homing routine (home-to-hard stop only in this mode). Move distance is selected with Inputs A and B. Pulsing the Enable/Trigger Input launches each move.

Position Control Incremental Positioning (4-Distance Programmable)

Signal	Function	Incremental Distance Settings				Example Timing
		Dist.1	Dist.2	Dist.3	Dist.4	
Input A	Increment Select A	LOW	HIGH	LOW	HIGH	
Input B	Increment Select B	LOW	LOW	HIGH	HIGH	
Enable/Trigger	Enable Trigger	Logic: High=Enable Low=Disable Pulse Enable line to trigger moves				
Notes: ClearPath can be programmed to home upon enable (see text for full details). Moves are triggered on rising edge of trigger pulse.						

Trigger pulse

I/O FUNCTIONS

Enable Input - Asserting this input energizes the motor shaft. A short pulse (user-definable) on this input is the trigger that starts a move. (A "pulse" is a momentary interruption of current into the Enable input.)

Input A - This input, along with Input B, selects which of the four defined position increments to send upon a trigger pulse.

Input B - This input, along with Input A, selects which of the four defined position increments to send upon a trigger pulse.

Output (HLFB) - See HLFB section for available modes.

Notes:

- A trigger pulse is required to launch each move. Move distance is selected with Input A and B.
- To create a longer continuous move, send multiple trigger pulses and ClearPath will automatically “chain” the move

increments together to form a single non-stop move. Note: To successfully “chain” move increments, the burst of trigger pulses must be sent rapidly. The pulse train must be received by the ClearPath during the acceleration through constant velocity portion of move, *but not during the deceleration phase*.

- If a trigger pulse is received during the deceleration phase of a running move, it will not be chained to the original move. In fact, the “late pulse” will trigger a separate move.

MODE CONTROLS

Position Increment Setup (cnts)

1) A off B off	2) A on B off	3) A off B on	4) A on B on
-50,000	+50,000	-10,000	+10,000

Set Move Increments
Enter move distance for each input state.

Torque Override Indicator
When lit, the main torque limit is being overridden by a secondary, user-set torque limit (e.g., when an axis is homing, the main torque limit may be overridden by the separate homing torque limit setting).

Torque Limit
Click to open Torque Limit Setup dialog.

Homing
Click to open Homing Setup dialog.

Speed Limit (RPM)
2,000.
Enter max. desired motor speed.

Accel Limit (RPM/s)
25,000
Enter max. desired acceleration rate.

Use multiple speed/accel
Use these controls to set different speeds and accelerations for each position increment.

Profile Conversion
RAS™ 44 ms
Adjust settings for RAS™ (or optional g-Stop™) to convert standard trapezoidal move profiles into profiles that reduce noise, resonance, and vibration.

Trigger Pulse
Click to adjust trigger pulse timing.

Hardware Input Status LEDs
Light = Input asserted (on)
Dark = Input de-asserted (off)

Inputs and Commands

Enable On/Off Trigger

Input A I-sel A

Input B I-sel B

ServoOn Output
Servo On

Override Inputs
Check to turn on Soft Controls. Override cannot be activated when ClearPath is hardware enabled.

Trg
Soft Inputs and LEDs emulate hardware inputs. For use only when Soft Controls are active.
Caution: motor may spin when enabled.

Set Home Posn
Click during homing operation to manually set home position.

Displays HILFB output status.

MOVE INCREMENTAL DISTANCE (2-DISTANCE, HOME TO HARD STOP)

Available on
MCPV

MODE DESCRIPTION

Change the state an input to tell ClearPath to move a user-defined, incremental distance from its current position. Send multiple, quick transitions to tell ClearPath to travel a multiple of any distance in one smooth, uninterrupted move.

What is Incremental Positioning?

An incremental move is referenced to its own starting position, not to an absolute “home” reference position. So, if the incremental move distance is set to +1000 counts, the shaft will move +1000 counts from its current position each time a move is launched.

Assert the Enable Input to energize the motor. (ClearPath can be set up to perform an optional home to hard stop upon enable.) Change the state of Input B to select which of the two move increments is currently active. Change the state of Input A to launch each move at the user-defined speed and acceleration. Briefly pulse the Enable input to execute the next move at the alternate speed limit.

Position Control Incremental Positioning (2 Incremental Distances, HS Home)

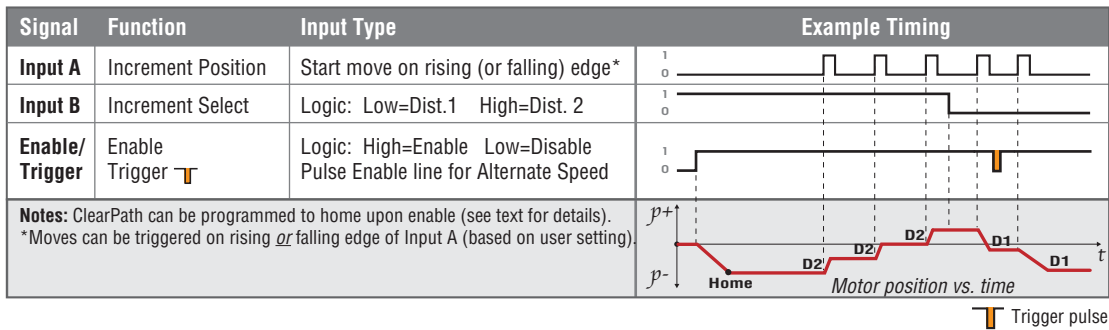

I/O FUNCTIONS

Enable Input - Asserting this input energizes the motor shaft. A short pulse (user-definable) on this input tells ClearPath to use the alternate speed limit setting for the next move.

Input A - Turning this input on (or off, if desired) sends the position increment.

Input B - This input selects which of the two defined position increments to send.

Output (HLFB) - See HLFB section for available modes.

Notes:

- Send incremental move commands by turning Input A either on or off (user settable).

- Multiple position increments can be smoothly chained together (i.e., with no stops in between) by toggling Input A before ClearPath starts decelerating. For example, three quick cycles of Input A will create one smooth move of three times the length of the selected position increment.
- If you need to move in both directions, make sure you define both a positive and a negative position increment.

MODE CONTROLS

Set Move Increments
Enter move distance for each state of Input B.

Position Increment Setup (cnts)
1) B off: -25,000
2) B on: +25,000

Select how you want to launch incremental moves; when Input A turns on, or when it turns off.

Increment Posn When...
Input A Turns On
Input A Turns On
Input A Turns Off

Enter alternate motor speed (optional).

Alt Speed Limit (RPM)
20.00

Torque Override Indicator
When lit, the main torque limit is being overridden by a secondary, user-set torque limit (e.g., when an axis is homing, the main torque limit may be overridden by the separate homing torque limit setting).

Click to open Torque Limit Setup dialog.

Click to open Homing Setup dialog.

Speed Limit (RPM)
500.00

Accel Limit (RPM/s)
15,000

Use multiple speed/accel

Use these controls to set different speeds and accelerations for each position increment.

Profile Conversion
RAS™ 44 ms
Setup...

Adjust settings for RAS™ (or optional g-Stop™) to convert standard trapezoidal move profiles into profiles that reduce noise, resonance, and vibration.

Torque Limit
OVR Setup...

Homing
 Disabled
 Enabled
Setup...

Trigger Pulse
Setup...

Click to adjust trigger pulse timing.

Hardware Input Status LEDs
Light = Input asserted (on)
Dark = Input de-asserted (off)

Inputs and Commands
Enable On/Off, Alt Spd, Input A Incr Posn, Input B Incr Select

ServoOn Output
Servo On

Override Inputs

Check to turn on Soft Controls. Override cannot be activated when ClearPath is hardware enabled.

Soft Inputs and LEDs emulate hardware inputs. For use only when Soft Controls are active.
Caution: motor may spin when enabled.

Alt Spd

Click during homing operation to manually set home position.

Displays HLFB output status.

MOVE INCREMENTAL DISTANCE (2-DISTANCE, HOME-TO-SWITCH)

Available on

MCPV

MODE DESCRIPTION

Send a trigger pulse to tell ClearPath to move a user-defined distance from its current position. Send multiple, quick trigger pulses to tell ClearPath to travel a multiple of any distance in one smooth, uninterrupted move.

Incremental Positioning

An incremental move is referenced to its own starting position, not to an absolute “home” reference position. So, if the incremental move distance is set to +1000 counts, the shaft will move +1000 counts from its current position each time a trigger pulse is received.

Assert the Enable Input to energize the motor. ClearPath can be set to perform an optional homing routine (home-to-switch only in this mode). Incremental move distance is selected with Input A. Pulsing the Enable/Trigger Input launches each move.

Position Control Incremental Positioning (2 Incremental Distances)

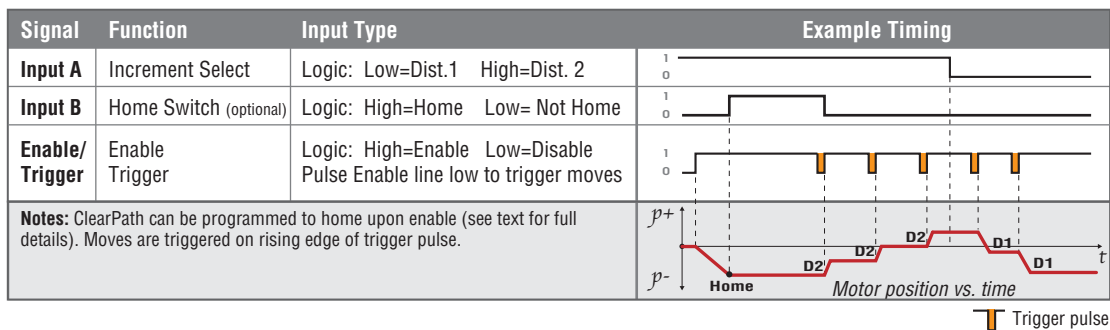

I/O FUNCTIONS

Enable Input - Asserting this input energizes the motor shaft.

Input A - This input selects which of the two defined position increments to send upon a trigger pulse.

Input B - This input is connected to the home switch/sensor. Its function is defined in the homing setup dialog. Home switch polarity can be inverted if desired.

Output (HLFB) - See HLFb section for available modes.

Notes:

- A trigger pulse is required to launch each incremental move. Move distance is selected with Input A.
- To create a longer continuous move, you can send multiple trigger pulses and ClearPath will automatically “chain” the move increments together to form a single seamless move. Note: To successfully “chain” move increments, the burst of trigger pulses must be sent rapidly. They must be received by

the ClearPath during the acceleration through constant velocity portion of move, *but not during the deceleration phase*. If a trigger pulse is received during the deceleration phase of a move, that move will run to completion (motor will stop). Then the next incremental move will execute.

MODE CONTROLS

Set Move Increments
Enter move distance for each state of Input B.

Position Increment Setup (cnts)

1) A off	2) A on
-32,000	+8,000

Torque Override Indicator
When lit, the main torque limit is being overridden by a secondary, user-set torque limit (e.g., when an axis is homing, the main torque limit may be overridden by the separate homing torque limit setting).

Torque Limit
OVR Setup...

Homing
 Disabled
 Enabled
 Setup...

Speed Limit (RPM)
3,000

Accel Limit (RPM/s)
20,000

Use multiple speed/accel Spd/Acc Setup...

Profile Conversion
g-Stop™ 43 ms
Setup...

Trigger Pulse
Setup...

Enter max. desired motor speed.

Enter max. desired acceleration rate.

Use these controls to set different speeds and accelerations for each position increment.

Adjust settings for RAS™ (or optional g-Stop™) to convert standard trapezoidal move profiles into profiles that reduce noise, resonance, and vibration.

Click to open Torque Limit Setup dialog.

Click to open Homing Setup dialog.

Click to adjust trigger pulse timing.

Hardware Input Status LEDs
Light = Input asserted (on)
Dark = Input de-asserted (off)

Inputs and Commands

<input type="checkbox"/> Override Inputs	Enable On/Off <input checked="" type="checkbox"/>	Trigger <input checked="" type="checkbox"/>	Input A Increment <input checked="" type="checkbox"/>	Input B Home Switch <input checked="" type="checkbox"/>	ASG-Position At Position
	<input type="checkbox"/>	<input type="checkbox"/> Trg	<input type="checkbox"/>	<input type="checkbox"/>	

Check to turn on Soft Controls. Override cannot be activated when ClearPath is hardware enabled.

Soft Inputs and LEDs emulate hardware inputs. For use only when Soft Controls are active. **Caution: motor may spin when enabled.**

Displays HILFB output status.

MOVE INCREMENTAL DISTANCE (1-DISTANCE, HOME-TO-SWITCH)

Available on

MCPV

MODE DESCRIPTION

ClearPath will make an incremental move when the state of Input A changes. If automatic homing is on, ClearPath will seek for the home switch connected to Input B the first time it is enabled after power up, or, if desired, each time it is enabled.

What is Incremental Positioning?

An incremental move is referenced to its own starting position, not to an absolute “home” reference position. So, if the incremental move distance is set to +1000 counts, the shaft will move +1000 counts from its current position each time a move is launched.

Assert the Enable Input to energize the motor. ClearPath can be set up to perform an optional homing routine upon enable (home-to-switch only in this mode). Change the state of Input A to launch each move at the user-defined speed and acceleration. Briefly pulse the Enable input to execute the next move at the alternate speed limit.

Position Control Incremental Positioning (1 Incremental Distance, Home-To-Switch)

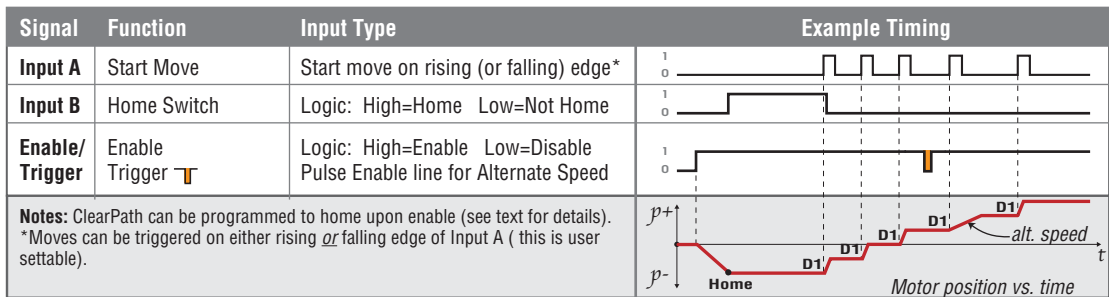

Trigger pulse

I/O FUNCTIONS

Enable Input - Asserting this input energizes the motor shaft. A short trigger pulse on this input tells ClearPath to use the alternate speed limit setting for the next move.

Input A - Turning this input on (or off, if desired) sends the position increment.

Input B - This input is connected to the home switch/sensor. Its function is defined in the homing setup dialog.

Output (HLFB) - See HLFb section for available modes.

Notes:

- Send incremental moves by turning Input A either on or off (this is user settable).
- Multiple position increments can be smoothly chained together (i.e., with no stops in between) by toggling Input A before

ClearPath starts decelerating. For example, three quick cycles of Input A will create one smooth move of three times the length of the position increment.

- The direction of the move is specified by the sign of the position increment (i.e., a positive position increment will move the shaft in a counter-clockwise direction, while a negative increment will cause a move in the clockwise direction).
- Note that this 1 increment mode only allows for movement in one direction."

MODE CONTROLS

Set Move Increment
Enter move distance here.

Position Increment (cnts)
+620

Increment Posn When...
Input A Turns On

Select how you want to launch incremental moves; when Input A turns on, or when it turns off.

Enter alternate motor speed (optional).

Alt Speed Limit (RPM)
22

Torque Override Indicator
When lit, the main torque limit is being overridden by a secondary, user-set torque limit (e.g., when an axis is homing, the main torque limit may be overridden by the separate homing torque limit setting).

Click to open Torque Limit Setup dialog.

Click to open Homing Setup dialog.

Speed Limit (RPM)
2,003

Enter max. desired motor speed.

Accel Limit (RPM/s)
10,203

Enter max. desired acceleration rate.

Profile Conversion
RAS™ 25 ms

Adjust settings for RAS™ (or optional g-Stop™) to convert standard trapezoidal move profiles into profiles that reduce noise, resonance, and vibration.

Setup...

Trigger Pulse
Setup...

Click to adjust trigger pulse timing.

Hardware Input Status LEDs
Light = Input asserted (on)
Dark = Input de-asserted (off)

Inputs and Commands

Enable On/Off

Input A Incr Posn

Input B Home Switch

ASG-Position

At Position

Override Inputs

Check to turn on Soft Controls. Override cannot be activated when ClearPath is hardware enabled.

Soft Inputs and LEDs emulate hardware inputs. For use only when Soft Controls are active.
Caution: motor may spin when enabled.

Displays HLFB output status.

PULSE BURST POSITIONING

Available on
MCPV

MODE DESCRIPTION

ClearPath will move a distance proportional to the number of pulses sent to Input B. This mode offers much of the flexibility of a “step-and-direction” system, without the need for an expensive indexer to create smooth move trajectories (that function is handled by ClearPath’s internal trajectory generator). This mode is limited to two speeds and one acceleration/deceleration rate set by the user.

Note: A fairly simple PLC counter or a software loop can be used to generate pulses for use with this mode.

Assert the Enable Input to energize the motor. (Note: ClearPath can be configured to perform a homing routine upon enable.) To execute positioning moves, send a high speed stream of pulses to Input B, where each pulse represents an incremental unit of distance. Total move distance is determined by the number of pulses sent to Input B.

Pulse Positioning Pulse Burst Positioning

Signal	Function	Input Type	Example Timing
Input A	Direction Select	Logic: High=CW Low=CCW	
Input B	Pulse Input	Pulse: High-Speed Pulse Burst	
Enable Trigger	Enable Speed Select	Logic: High=Enable Low=Disable Pulse low to select alternate speed	
<p>Notes: Absolute Minimum Pulse Width = 750nS. See notes below for important information on how to determine min/max pulse input frequency range.</p>			

Trigger pulse

I/O FUNCTIONS

Enable Input - Asserting this input energizes the motor shaft. A short pulse (user-definable) on this input tells ClearPath to use the alternate speed limit setting for the next move.

Input A - This input selects the direction of rotation.

Input B - This input is connected to the pulse source.

Output (HLFB) - See HLFB section for available modes.

Notes:

- The frequency of the pulse train applied to Input B must always be higher than the specified speed limit(s). This ensures that the motor's pulse buffer is never empty. See the “Burst Frequency Spec” (circled in red on the figure below) for the range of allowable pulse input frequencies.
- Sending pulses at a fixed frequency is OK; in fact, this is one of the reasons why this mode was developed. Just send a burst of

pulses and ClearPath creates a smooth motion profile for you automatically.

MODE CONTROLS

Select number of input pulses required to rotate the motor shaft exactly one revolution.

Check to reverse direction of motor shaft rotation.

Click to adjust trigger pulse timing.

Click to open Torque Limit Setup dialog.

Click to open Homing Setup dialog.

Input Resolution (Pulses/Revolution): 6400

Reverse Direction

Trigger Pulse Setup...

Torque Limit OVR Setup...

Homing Disabled Enabled Setup...

Speed Limit (RPM): 2,200

Burst Freq Spec ⚠

Alt Speed Limit (RPM): 400

Accel (RPM/s): 10,500

Profile Conversion RAS™ 66 ms Setup...

Enter max. desired motor speed.

Automatically displays allowable range of input pulse frequencies (this range is based on Input Resolution and Speed Limit settings).

Enter alternate motor speed (optional).

Enter max. desired acceleration rate.

Adjust settings for RAS™ (or optional g-Stop™) to convert standard trapezoidal move profiles into profiles that reduce noise, resonance, and vibration.

Torque Override Indicator When lit, the main torque limit is being overridden by a secondary, user-set torque limit (e.g., when an axis is homing, the main torque limit may be overridden by the separate homing torque limit setting).

Hardware Input Status LEDs
Light = Input asserted (on)
Dark = Input de-asserted (off)

Inputs and Commands

Enable On/Off <input checked="" type="radio"/> Alt Spd <input checked="" type="radio"/>	Input A Dir (CW/CCW) <input checked="" type="radio"/>	Input B Step CCW <input checked="" type="radio"/>	ServoOn Output <input checked="" type="button" value="Servo On"/>
<input type="checkbox"/> Override Inputs	<input type="checkbox"/> Alt Spd	<input type="checkbox"/> Jog CCW	

Check to turn on Soft Controls. Override cannot be activated when ClearPath is hardware enabled.

Soft Inputs and LEDs emulate hardware inputs. For use only when Soft Controls are active. **Caution: motor may spin when enabled.**

Displays HILFB output status.

Note: Input Resolution (see upper left of mode controls screen capture above) is defined as the number of pulses that must be sent to the motor's input (Input B in this mode) to make the shaft rotate exactly one revolution. Please see the Resolution appendix for a detailed discussion of this topic.

Note: Pulse Width Requirements. The minimum step pulse width used with this mode is dependent on the type of controller output and the control cable length. Refer to the [Step and Direction Timing section](#) of the user manual for details.

MULTI-SENSOR POSITIONING: BI-DIRECTIONAL (HOME TO HARD STOP)

Available on

MCPV

MODE DESCRIPTION

Move to a maximum of 16 different positions using simple I/O from your PLC, microcontroller or similar to control ClearPath's direction and position.

Wire up to 16 switches or sensors in series with Input B. Assert the Enable Input to energize the motor windings. Once homing is complete, a trigger pulse starts ClearPath moving in the direction indicated by Input A. When Input B sees a count of transitions equal to the count of trigger pulses, ClearPath will ramp to a stop at the user-defined rate. (These transitions are typically switch closures or sensor interruptions.)

Position Control Multi-Sensor Position: Bi-directional (Home to Hard Stop)

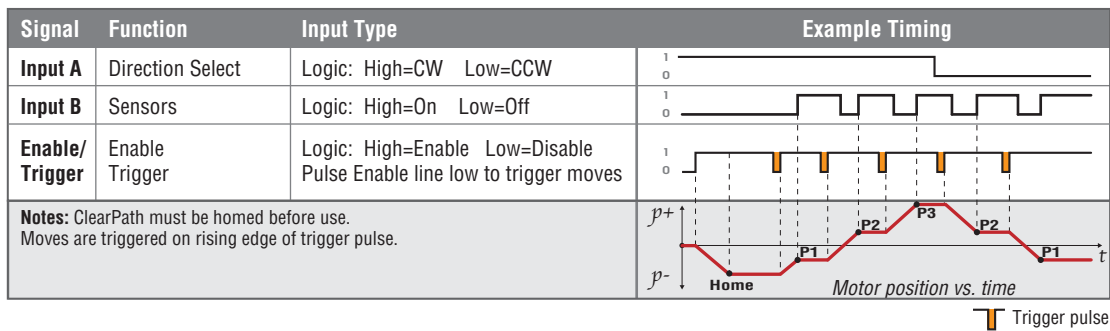

I/O FUNCTIONS

Enable Input - Asserting this input energizes the motor shaft. A short pulse (user-definable) on this input is the trigger that starts a move. (A "pulse" is a momentary interruption of current into the Enable input.)

Input A - This input selects the direction of rotation.

Input B - Transitions on this input count up until they equal the count of transitions seen on Input A, at which time ClearPath will ramp to a stop.

Output (HLFB) - See HLFb section for available modes.

Notes:

- Up to 16 sensors/switches can be placed along an axis and their outputs wired-ORed for multiple stops.
- Multiple trigger pulses issued in the same direction before a sensor is detected will cause the motor to continue through the number of sensors matching the number of pulses seen.
Example: If you send 3 trigger pulses, ClearPath moves to the third sensor position.
- ClearPath will always finish moves in one direction before executing moves commanded in the other direction.

- Homing is required in this mode; it can be performed upon first enable after power up, or upon every enable.
- Time to disable depends on trigger pulse setting, i.e. a longer trigger pulse setting will result in a longer time to disable.
- Once all sensors are mapped, the motor will stop at the same position each time, regardless of the direction of approach.

MODE CONTROLS

Select which state of Input A results in clockwise rotation at the motor shaft.

Select whether a sensor actuation turns Input B on or off.

Select sensor discovery method.

Click to open Torque Limit Setup dialog.

Click to open Homing Setup dialog.

Enter total number of sensors installed.

Direction: CW = Input A On

Polarity: CW = Input A Off

Arrival at Sensor...: Turns Off Input B

Sensor Total: 4

Map Sensors: As Detected

Torque Limit: Setup...

Homing: Setup...

Speed Limit (RPM): 1,500

Accel (RPM/s): 50,000

Profile Conversion: RAS™ 21 ms

Sensor Latch (cnts): 50

Trigger Pulse: Setup...

Stops 5,813 cnts Beyond Sensor

Enter max. desired motor speed.

Automatically displays the distance, past a sensor that a motor will stop, given current settings for speed, accel, and RAS/gStop.

Enter max. desired acceleration rate.

Adjust settings for RAS™ (or optional g-Stop™) to convert standard trapezoidal move profiles into profiles that reduce noise, resonance, and vibration.

Once a sensor is entered, ClearPath ignores sensors until it has moved at least this (user defined) distance.

Click to adjust trigger pulse timing.

Torque Override Indicator
When lit, the main torque limit is being overridden by a secondary, user-set torque limit (e.g., when an axis is homing, the main torque limit may be overridden by the separate homing torque limit setting).

Hardware Input Status LEDs
Light = Input asserted (on)
Dark = Input de-asserted (off)

Displays current commanded sensor position.

Inputs and Commands: Enable On/Off Trigger, Input A Dir (CW/CCW), Input B Sensor(s)

Sensor Index: 4

ServoOn Output: Servo On

Override Inputs

Soft Inputs and LEDs emulate hardware inputs. For use only when Soft Controls are active. **Caution: motor may spin when enabled.**

Click during homing operation to manually set home position.

Displays HLFB output status.

MULTI-SENSOR POSITIONING: UNIDIRECTIONAL (SENSORLESS HOMING)

Available on
MCPV

MODE DESCRIPTION

Use simple I/O from your PLC, microcontroller etc. to command ClearPath to move to the sensor or switch of your choosing. Direction, speed, and acceleration are all user-defined in MSP.

This mode starts by finding a user-defined, shaft angle home position. Then, upon seeing a transition on Input A, ClearPath will start to move in one, fixed, user-defined direction, at one of two velocities. ClearPath will ramp to a stop at the user-defined rate when Input B has seen a count of transitions equal to the count of transitions on Input A. (These transitions are typically switch closures or sensor interruptions.)

Position Control Multi-Sensor Position: Unidirectional (Sensorless Homing)

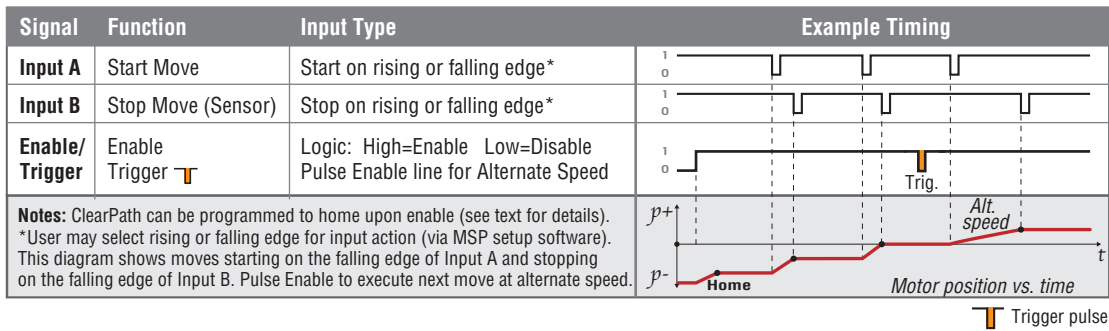

I/O FUNCTIONS

Enable Input - Asserting this input energizes the motor shaft. A short pulse (user-definable) on this input tells ClearPath to use the alternate speed limit setting for the next move. (A "pulse" is a momentary interruption of current into the Enable input.)

Input A - A transition on this input starts a move. You can define whether the move starts on a rising or falling transition.

Input B - Transitions on this input count up until they equal the count of transitions seen on Input A, at which time ClearPath will ramp to a stop.

Output (HLFB) - See HLFB section for available modes.

Notes:

- This mode can also be used without homing if all the desired stopping locations are equivalent (e.g., an indexing table with four positions spaced an even 90 degrees apart).

MODE CONTROLS

Select which edge transition at Input A will start a move.

Select whether a sensor actuation turns Input B on or off.

Once a sensor is entered, ClearPath ignores sensors until it has moved at least this (user-defined) distance.

Select direction of rotation.

Click to open Torque Limit Setup dialog.

Click to open Homing Setup dialog.

Start Move When...
Input A Turns On

Arrival at Sensor...
Turns Off Input B

Direction
CW

Sensor Latch (cnts)
50

Torque Limit
OVR Setup...

Homing
Disabled
Enabled Setup...

Speed Limit (RPM)
60.
Stops 122 cnts Beyond Sensor

Accel (RPM/s)
12,500

Profile Conversion
RAS™ 16 ms
Setup...

Alt Speed Limit (RPM)
5

Trigger Pulse
Setup...

Enter max. desired motor speed.

Automatically displays the distance, past a sensor that a motor will stop given the current settings for speed, accel, and RAS/gStop.

Enter max. desired acceleration rate.

Adjust settings for RAS™ (or optional g-Stop™) to convert standard trapezoidal move profiles into profiles that reduce noise, resonance, and vibration.

Enter alternate motor speed limit (optional).

Click to adjust trigger pulse timing.

Torque Override Indicator
When lit, the main torque limit is being overridden by a secondary, user-set torque limit (e.g., when an axis is homing, the main torque limit may be overridden by the separate homing torque limit setting).

Hardware Input Status LEDs
Light = Input asserted (on)
Dark = Input de-asserted (off)

Inputs and Commands

Enable
On/Off Alt Speed

Input A
Start Move

Input B
Stop Move

ASG-Position
At Position

Override Inputs

Check to turn on Soft Controls. Override cannot be activated when ClearPath is hardware enabled.

Soft Inputs and LEDs emulate hardware inputs. For use only when Soft Controls are active.
Caution: motor may spin when enabled.

Displays HLFB output status.

MULTI-SENSOR POSITIONING: UNIDIRECTIONAL (HOME TO SENSOR)

Available on

MCPV

MODE DESCRIPTION

Use simple I/O from your PLC, microcontroller etc. to command ClearPath to move to the sensor or switch of your choosing. Direction, speed, and acceleration are all user-defined in MSP. Optional homing (home-to-sensor) is available.

This mode starts by finding a home sensor wired to Input A. Then, a “trigger” pulse on the Enable input starts ClearPath moving in one, fixed, user-specified direction. When Input B sees a count of transitions equal to the count of trigger pulses, ClearPath will ramp to a stop at the user-defined rate. (These transitions are typically switch closures or sensor interruptions.)

Position Control Multi-Sensor Position: Unidirectional (Home to Sensor)

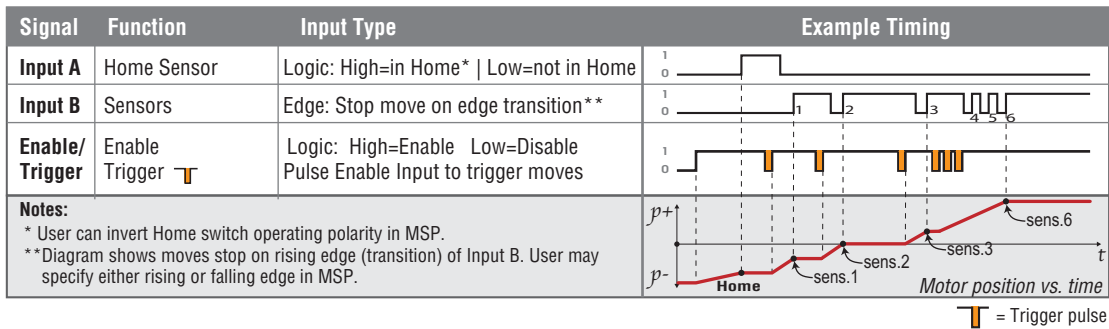

I/O FUNCTIONS

Enable Input - Asserting this input energizes the motor shaft. A short pulse (user-definable) on this input is the trigger that starts a move. (A "pulse" is a momentary interruption of current into the Enable input.)

Input A - This input is connected to the home switch. Homing options are set in the Homing Setup dialog.

Input B - Transitions on this input count up until they equal the count of trigger pulses seen on the Enable input, at which time ClearPath will ramp to a stop.

Notes:

- ClearPath can be programmed to home upon enable. If homing is not needed because all the desired stopping locations are equivalent (e.g., an indexing table with four positions spaced an even 90 degrees apart), consider using the Rotary with Sensorless Homing mode. This will allow the use of a second, alternate move velocity if desired.
- Moves are triggered by quickly pulsing the Enable input. Moves stop when sensor count at Input B matches trigger pulse count.
- Trigger pulses made in rapid succession result in longer, continuous moves.

MODE CONTROLS

Select whether a sensor actuation turns Input B on or off.

Turns On Input B
Turns Off Input B

Select direction of rotation.

Direction
CW

Once a sensor is entered, ClearPath ignores sensors until it has moved at least this (user-defined) distance.

Sensor Latch (cnts)
50

Click to open Torque Limit Setup dialog.

Torque Limit
OVR Setup...

Click to open Homing Setup dialog.

Homing
Disabled
Enabled
Setup...

Speed Limit (RPM)
60.

Accel (RPM/s)
8,000

Profile Conversion
RAS™ 40 ms
Setup...

Trigger Pulse
Setup...

Stops 284 cnts Beyond Sensor

Enter max. desired motor speed.

Enter max. desired acceleration rate.

Adjust settings for RAS™ (or optional g-Stop™) to convert standard trapezoidal move profiles into profiles that reduce noise, resonance, and vibration.

Torque Override Indicator
When lit, the main torque limit is being overridden by a secondary, user-set torque limit (e.g., when an axis is homing, the main torque limit may be overridden by the separate homing torque limit setting).

Click to adjust trigger pulse timing.

Hardware Input Status LEDs
Light = Input asserted (on)
Dark = Input de-asserted (off)

Inputs and Commands

Override Inputs	Enable On/Off	Trigger	Input A Home Switch	Input B Sensor(s)	ASG-Position At Position
	<input type="checkbox"/>	<input type="checkbox"/>	<input type="checkbox"/>	<input type="checkbox"/>	

Check to turn on Soft Controls. Override cannot be activated when ClearPath is hardware enabled.

Soft Inputs and LEDs emulate hardware inputs. For use only when Soft Controls are active.
Caution: motor may spin when enabled.

Displays HLFB output status.

FOLLOW DIGITAL POSITION COMMAND: UNIPOLAR PWM COMMAND

Available on

MCPV

MODE DESCRIPTION

ClearPath will servo to a position between two user-defined limits proportional to the PWM duty cycle of the signal on input B.

Position Control Follow Digital Position: Unipolar PWM Command

Signal	Function	Input Type	Example Timing
Input A	Home Sensor or Command Lock	Logic: High=In Sensor Low=Not in Sens.	
		Logic: High=Lock ON Low=Lock OFF	
Input B	Position	Pulse: Variable PWM	
		Duty cycle of applied PWM signal (%)	
Enable	Enable	Logic: High=Enable Low=Disable	
Notes: Home sensor not used in this example. See Homing section for details.			

I/O FUNCTIONS

Enable Input - Asserting this input energizes the motor shaft.

Input A - Asserting this input will make ClearPath continue to servo to its current position regardless of any changes to the duty cycle on Input B. Alternatively, this signal can be used as a home sensor input.

Input B - This input is connected to a PWM signal whose duty cycle represents the desired position.

Output (HLFB) - See HLFb section for available modes.

Notes:

- A loss of modulation (meaning Input B has no transitions for more than 50 ms) is considered an error condition, and ClearPath will maintain its current position.
- A duty cycle of nearly 0% or 100% (with a state transition at least every 50 ms) will command ClearPath to move to position 0 or position 1, respectively.
- A duty cycle between 0% and 100% will command a position proportionally between position 0 and 1.
- PWM input frequency range: 20 Hz to 30 kHz.

MODE CONTROLS

The screenshot shows the Mode Controls software interface with several sections and callouts:

- Position Range Setup (cnts):** Includes fields for "Posn at 0% PWM" (+10,000) and "Posn at 100% PWM" (+100,000). A callout above says "Define the ends of travel here (in encoder counts)."
- Invert PWM Input:** A checkbox that is currently unchecked. A callout above explains: "Check box to invert how PWM duty cycle is measured by ClearPath." It shows two options: "NO CHECK" (Duty cycle is % of period high) and "CHECK" (Duty cycle is % of period low).
- Speed Limit (RPM):** A field containing "1,500.". A callout below says "Enter max. desired motor speed."
- Profile Conversion:** A field containing "RAS™ 44 ms" and a "Setup..." button. A callout below says "Adjust settings for RAS™ (or optional g-Stop™) to convert standard trapezoidal move profiles into profiles that reduce noise, resonance, and vibration."
- Deadband (cnts):** A field containing "1,600". A callout below says "Commanded changes in position will be ignored until this distance is exceeded. (Prevents motor hunting due to command signal dither.)"
- Input A Mode:** A dropdown menu currently set to "Command Lock". A callout below says "With Command Lock selected (and the input asserted) ClearPath will servo to its current position regardless of changes made to the PWM duty cycle." It also offers an alternative: "Select Home Sensor to use Input A as a home sensor input."
- Torque Limit:** A section with an "OVR" indicator and a "Setup..." button. A callout above says "Click to open Torque Limit Setup dialog."
- Homing:** A section with a "Setup..." button. A callout above says "Click to open Homing Setup dialog."
- Torque Override Indicator:** A callout box explaining: "When lit, the main torque limit is being overridden by a secondary, user-set torque limit (e.g., when an axis is homing, the main torque limit may be overridden by the separate homing torque limit setting)."
- Hardware Input Status LEDs:** A legend stating "Light = Input asserted (on)" and "Dark = Input de-asserted (off)".
- Inputs and Commands:** A section with "Enable On/Off" (checked), "Input A Cmd Lock" (checked), "Input B (% Duty Cycle)" (75%), "Commanded Position (cnts)" (+77,442), and "ServoOn Output" (Servo On). Below this is an "Override Inputs" checkbox (unchecked) and "Soft Inputs and LEDs" (unchecked).
- Commanded Position (cnts):** A field showing "+67,600". A callout above says "Displays HLFb output status."
- ServoOn Output:** A "Set Home Posn" button. A callout below says "Click during homing operation to manually set home position."
- Override Inputs:** A callout below says "Check to turn on Soft Controls. Override cannot be activated when ClearPath is hardware enabled."
- Soft Inputs and LEDs:** A callout below says "Soft Inputs and LEDs emulate hardware inputs. For use only when Soft Controls are active. Caution: motor may spin when enabled."

FOLLOW DIGITAL POSITION COMMAND: FREQUENCY COMMAND

Available on

MODE SUMMARY

MCPV

ClearPath will servo to a position between two user-defined limits based on the frequency of the signal on Input B.

Position Control Follow Digital Position: Frequency Command

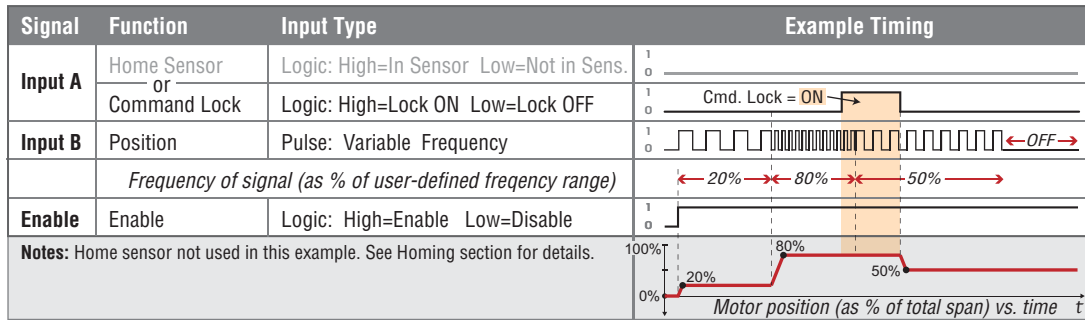

I/O FUNCTIONS

Enable Input - Asserting this input energizes the motor shaft.

Input A - Asserting this input will make ClearPath continue to servo to its current position regardless of any changes to the frequency on Input B. Alternatively, this signal can be used as a home sensor input.

Input B - This input is connected to a digital signal whose frequency represents the desired position.

Output (HLFB) - See HLFB section for available modes.

Notes:

- A signal frequency on Input B equal to the user-defined minimum will move the motor to position 0. A frequency equal to the user-defined maximum will move the motor to position 1.
- Input frequency range: 20 Hz to 700 kHz.
- Frequencies between the minimum and maximum will command positions (proportionally) between position 0 and 1.
- If there are no transitions on Input B for 50 ms or more, this will be considered an error condition, and the motor will hold its current position.

MODE CONTROLS

Set Position Range.
Define the ends of travel in encoder counts.

Set Min/Max Frequency. During operation, motor position is controlled by Input B signal frequency. Example; based on setting sbelow, a 10 kHz signal will command the motor to one end of travel (+100,000) and a 5kHz signal will command the motor to the other end of travel (+10,000 counts).

Click to open Torque Limit Setup dialog.

Click to open Homing Setup dialog.

Position Range Setup (cnts)

Posn at Min Freq: +10,000

Posn at Max Freq: +100,000

Min Frequency (kHz)

5.0

Max Frequency (kHz)

10.0

Torque Limit

OVR Setup...

Homing

Setup...

Speed Limit (RPM)

1,500.

Profile Conversion

RAS™ 44 ms

Setup...

Deadband (cnts)

1,600

Input A Mode

Command Lock

Torque Override Indicator

When lit, the main torque limit is being overridden by a secondary, user-set torque limit (e.g., when an axis is homing, the main torque limit may be overridden by the separate homing torque limit setting).

Enter max. desired motor speed.

Adjust settings for RAS™ (or optional g-Stop™) to convert standard trapezoidal move profiles into profiles that reduce noise, resonance, and vibration.

Commanded changes in position will be ignored until this minimum distance is exceeded. (Prevents motor hunting due to command signal dither).

With **Command Lock** selected (and the input asserted) ClearPath will servo to its current position regardless of changes made to the command frequency.

Hardware Input Status LEDs

Light = Input asserted (on)
Dark = Input de-asserted (off)

Command Lock **Home Sensor**

OR

Select **Home Sensor** to use Input A as a home sensor input.

Displays HLFb output status.

Inputs and Commands

Enable On/Off

Input A Cmd Lock

Input B (kHz)

7.483 kHz

Commanded Position (cnts)

+54,604

ServoOn Output

Servo On

Override Inputs

Check to turn on Soft Controls. Override cannot be activated when ClearPath is hardware enabled.

Soft Inputs and LEDs emulate hardware inputs. For use only when Soft Controls are active. **Caution: motor may spin when enabled.**

Click during homing operation to manually set home position.

TEKNIC, INC.

TEL. (585) 784-7454

OPERATIONAL MODES: SDSK AND SDHP

The ClearPath SD (Step & Direction) family was designed to replace stepper motor/drive systems with a single, cost-effective unit.

Note: ClearPath SDSK and SDHP models accept **quadrature AB** signal sources as well as **step & direction** signals.

STEP & DIRECTION

Available on
SDSK + SDHP

MODE DESCRIPTION

Enable your ClearPath and send industry standard step & direction signals to Inputs A and B, and ClearPath faithfully follows them. Use the included RAS (Regressive Auto Spline) feature to reduce vibration and noise. This mode is great for replacing stepper motor and drive systems with a single, compact device that costs less and does more.

ClearPath SD models require step and direction signals generated from an external device such as an indexer, microcontroller, or similar.

Stepper Replacement Step and Direction Input Control

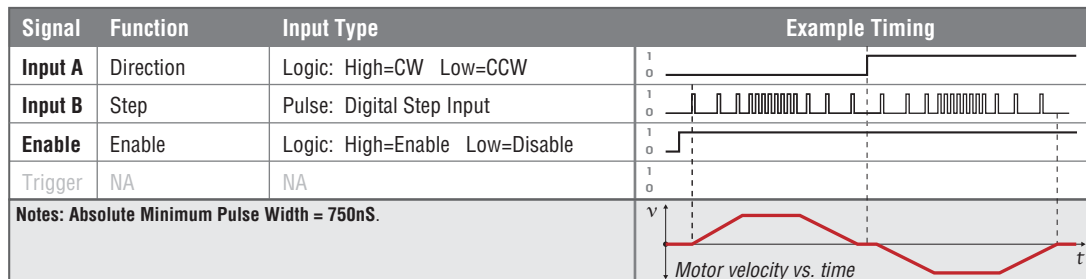

Step and Direction Inputs and Timing

I/O FUNCTIONS

Enable Input - Asserting this input energizes the motor shaft.

Input A - Direction input.

Input B - Step input.

Output (HLFB) - See HLFB section for available modes.

Notes:

- Minimum pulse width (for high and low states) = 750 nS. See [Step & Direction Pulse Timing Information](#) (later in this section) for details.
- Maximum pulse input frequency = 667kHz **at 50% duty cycle**.
- Motion occurs on the falling edge of each step input pulse.
- Time before Disable = 10 mS.

MODE CONTROLS

The screenshot shows the Mode Controls interface with the following elements and annotations:

- Input Resolution (Pulses/Revolution):** A dropdown menu set to 6400. Annotation: "Select number of input pulses required to rotate the motor shaft exactly one revolution."
- Reverse Direction:** A checkbox. Annotation: "Check to reverse direction of motor shaft rotation."
- Torque Limit:** A section with an "OVR" indicator and a "Setup..." button. Annotation: "Click to open Torque Limit Setup dialog."
- Input Format:** A dropdown menu set to "Step+Direction". Annotation: "Choose pulse input format. Step & Direction or Quadrature"
- Torque Override Indicator:** A text box explaining: "When lit, the main torque limit is being overridden by a secondary, user-set torque limit (e.g., when an axis is homing, the main torque limit may be overridden by the separate homing torque limit setting)."
- Profile Conversion:** A section with "RAS™ 16 ms" and a "Setup..." button. Annotation: "Set jerk limit. Higher values result in smoother, more gradual transitions between move segments of differing acceleration; however, overall move time is increased."
- Homing:** A section with radio buttons for "Disabled" and "Enabled", and a "Setup..." button. Annotation: "Click to open Homing Setup window (when homing is enabled)."
- Hardware Input Status LEDs:** A section with "Light = Input asserted (on)" and "Dark = Input de-asserted (off)".
- Inputs and Commands:** A row of controls including "Enable On/Off", "Input A Dir (CW/CCW)", and "Input B Step CCW".
- ServoOn Output:** A blue button labeled "Servo On". Annotation: "Displays HILFB output status."
- Override Inputs:** A checkbox. Annotation: "Check to turn on Soft Controls. Override cannot be activated when ClearPath is hardware enabled."
- Soft Inputs and LEDs:** A section with "Jog CW" and "Jog CCW" buttons. Annotation: "Emulate hardware inputs. For use only when Soft Controls are active. **Caution: motor may spin when enabled.**"
- Vel. (RPM):** A text input field set to 15.0. Annotation: "Enter motor velocity. For use with Soft Controls."
- Accel. (RPM/s):** A text input field set to 5,000. Annotation: "Enter motor acceleration. For use with Soft Controls."

STEP & DIRECTION PULSE TIMING INFORMATION

This section contains:

- A step timing diagram applicable to ClearPath **Step and Direction mode** (SD models) and **Pulse Burst Positioning mode** (MCPV models).
- A table listing minimum step (pulse) timing requirements based on typical interface circuits and controller cable lengths.
- A section discussing **Step Timing Errors**, including common causes and fixes. This type of alert occurs when ClearPath identifies a problem with the timing and/or quality of the incoming controller pulses.

STEP/PULSE TIMING DIAGRAM

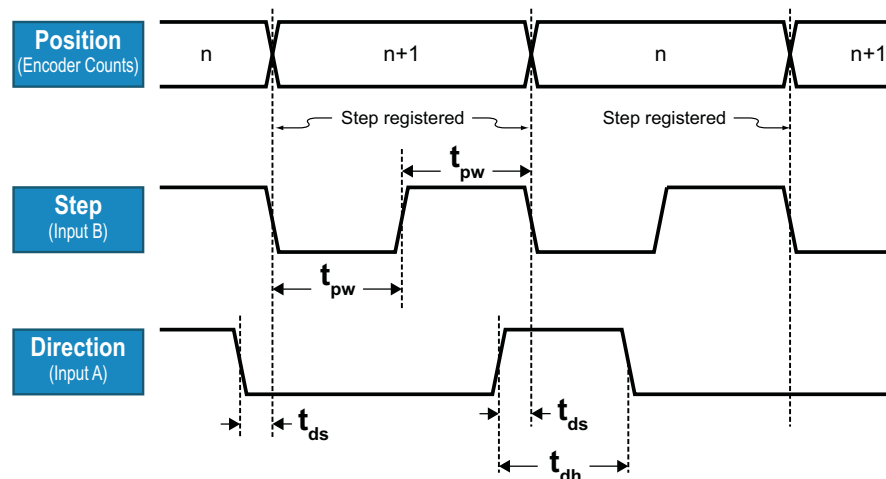

ClearPath Minimum Step/Direction Timing

- t_{pw} – Absolute minimum step pulse width: **750 nS** (applies to high and low states)
- t_{ds} – Absolute minimum time between direction change and step input change: **25 nS**
- t_{dh} – Absolute minimum direction hold time: **1 uS**

The timing diagram above shows *absolute minimum* step and direction timing values as measured directly at the ClearPath motor inputs. For recommended pulse width settings at the controller, see table **Minimum Pulse Width Settings for Step/Dir and Pulse Burst Positioning** (next page).

MINIMUM STEP PULSE WIDTH SETTINGS

The table below shows minimum step and direction pulse width requirements for actively driven vs. open collector pulse output architectures at different controller cable lengths (10 ft. and 55 ft. Teknic cables). This data applies to Step and Direction (SD models) and Pulse Burst Positioning modes (MCPV models).

Minimum Pulse Width Settings for Step/Dir and Pulse Burst Positioning

Output Type	Cable Length (Teknic Cable Part Number)			
	10 ft. (CPM-CABLE-CTRL-MU120)		55 ft. (CPM-CABLE-CTRL-MU660)	
	Minimum pulse width (time high)	Minimum pulse width (time low)	Minimum pulse width (time high)	Minimum pulse width (time low)
Totem-pole ¹ , 5V (actively driven)	750nS	750nS	750nS	750nS
Open collector, 249Ω pull-up to 5V	750nS	750nS	1,000nS	1,000nS
Open collector, 1kΩ pull-up to 5V	750nS	750nS	1,200nS	1,200nS
Open collector, 5V, no pull-up ²	900nS	900nS	1,700nS	1,700nS

1. Values based on driver chip P/N U74HC14.

2. This is not recommended. Always use a pull-up resistor for open collector outputs.

3. Open collector signals >5VDC should be evaluated for minimum stable pulse width settings.

STEP INPUT TIMING PROBLEMS

If ClearPath detects a problem with the incoming step/pulse stream (e.g. electrical noise, narrow pulses, pulses sent at excessively high frequency, etc.), it will execute a safety shutdown and alert the user with 1) an LED blink code at the motor, and 2) an exception/alert message viewable in MSP software as a **Step Timing Error**.

Application Note

All three ClearPath digital inputs are optically isolated and highly noise immune when used as recommended. ClearPath firmware was designed to detect, and alert the user to problems related to step and direction signaling.

COMMON CAUSES OF STEP TIMING ERRORS

Low voltage and/or low current from the controller. If the controller is outputting less than 4VDC and/or less than 8mA, it may be unable to reliably switch the ClearPath motor's inputs.

Pull-up resistor not installed or installed incorrectly. If your controller has open collector outputs, be sure to install the recommended pull-up resistors (at the controller end) as specified in the [ClearPath Inputs section](#).

Step pulses from the controller are out of spec. Problems can occur if the controller's step pulse frequency is higher than the ClearPath specification, or if the minimum step pulse time is less than 750 nS. **Note:** Pulse width and frequency settings are often configurable in the controller.

Signal pairs were not run from motor to controller. Always run two wires for each ClearPath I/O signal (e.g. Step+ & Step-) all the way from the ClearPath motor to the controller's outputs. *Avoid jumping or otherwise combining wires at the motor connector. For example, do not combine all of the return wires (i.e. Step-, Dir-, Enable-) together at the motor and run a single wire from the motor to the controller.* If your controller doesn't have enough connection points, always opt to *combine connections at the controller side.*

QUADRATURE INPUT

Available on
SDKS + SDHP

MODE DESCRIPTION

You send 2-channel quadrature signals and ClearPath moves in response. This mode is great for replacing quadrature driven stepper systems with a single compact device that costs less and does more.

To get started, select "Quadrature" from the Input Format drop down menu in the Mode Controls section.

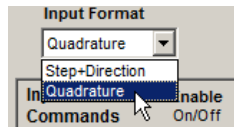

Assert the Enable input to energize the motor. Then, send quadrature pulses from an external controller to ClearPath Inputs A and B to command motion.

Stepper Replacement Quadrature Signal Control

Signal	Function	Input Type	Example Timing
Input A	Speed & Dir	Pulse: Quadrature A	
Input B	Speed & Dir	Pulse: Quadrature B	
Enable	Enable	Logic: High=Enable Low=Disable	
Trigger	NA	NA	

cc_mcsd

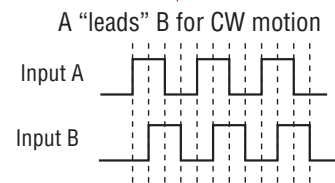
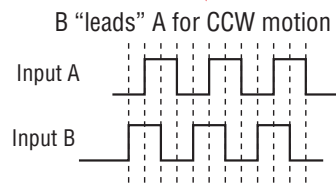

Step and Direction Inputs and Timing

I/O FUNCTIONS

Enable Input - Asserting this input energizes the motor shaft.

Input A - Quadrature A input.

Input B - Quadrature B input.

Output (HLFB) - See HLFb section for available modes.

Notes:

- Input B must lead Input A for CCW motion; Input A must lead Input B for CW motion.
- Maximum pulse input frequency = 667 kHz per channel **at 50% duty cycle.**

- Minimum pulse width (for high and low states) = 750 nS.
- Minimum time between adjacent channel transitions = 25 nS.
- Time before Disable = 10 mS.

MODE CONTROLS

Select number of input pulses required to rotate the motor shaft exactly one revolution.

Check to reverse direction of motor shaft rotation.

Click to open Torque Limit Setup dialog.

Click to open Homing Setup window (when homing is enabled).

Choose pulse input format. Step & Direction or Quadrature

Torque Override Indicator
When lit, the main torque limit is being overridden by a secondary, user-set torque limit (e.g., when an axis is homing, the main torque limit may be overridden by the separate homing torque limit setting).

Set jerk limit. Higher values result in smoother, more gradual transitions between move segments of differing acceleration; however, overall move time is increased.

Light = Input asserted (on)
Dark = Input de-asserted (off)

Displays HLCB output status.

Check to turn on Soft Controls. Override cannot be activated when ClearPath is hardware enabled.

Soft Inputs and LEDs
Emulate hardware inputs. For use only when Soft Controls are active. **Caution: motor may spin when enabled.**

Enter motor velocity. For use with Soft Controls.

Enter motor acceleration. For use with Soft Controls.

INPUT RESOLUTION SETTING

The Input Resolution setting provides a simple way to change the ratio of quadrature counts input to encoder counts moved.

Example 1) For a motor with a 6400 count/revolution encoder, setting the Input Resolution to **6400 quadrature counts/rev. results in a simple 1:1 relationship.** This just means that for each quadrature count seen at the ClearPath input, the motor shaft will rotate exactly 1 encoder count.

Example 2) For the same 6400 count motor, a setting of **800 quadrature counts per rev. results in a 1:8 relationship.** Thus, 1 quadrature count seen at the input will result in 8 encoder counts of motion at the shaft.

Available Input Resolution Settings

Input Resolution choices are 200, 400, 800, 1600, 3200, 6400, 12800, 25600, and 51200 quadrature counts per revolution.

APPENDIX A: TROUBLESHOOTING

LED BLINK CODES

Note: In cases where the same blink code is used for multiple different exceptions, connect your ClearPath to a PC running MSP to view the specific exception/shutdown information.

LED Code	Exception Type	Affect on Motion	Servo Status	How to Clear Exception	Status or Exception Message Reported in UI
No LED Activity	N/A	N/A	Servo off	N/A	No (or low) Power Verify power is correctly wired and within specified voltage range.
Yellow – on solid	N/A	N/A	Servo off	N/A	Status: Disabled Motor power is turned off.
Yellow - flicker	N/A	N/A	Servo on	N/A	Status: Performing Commutation Start-up
Green - flicker	N/A	N/A	Servo on	N/A	Status: Enabled Motor power is on. ClearPath will respond to motion commands.
Yellow - 2 blinks	Shutdown	Disallows motion	Servo off	Toggle Enable input	User Stop ESC key or button was pressed by the user.
Yellow - 2 blinks	Shutdown	Disallows motion	Servo off	Toggle Enable input	Motor Enable Conflict The hardware inputs did not match the active software override inputs when the motor was enabled via the hardware enable line.
Yellow - 3 blinks	Shutdown	Disallows motion	Servo off	Toggle Enable input	Max Bus Voltage Exceeded Probable cause: large regenerated voltage upon deceleration or high AC line voltage. Enable the Vector Regen Shunt (VRS) under the advanced menu as a possible remedy.
Yellow - 3 blinks	Shutdown	Disallows motion	Servo off	Toggle Enable input	Power Event Detected Probable cause: Dropped AC phase; Bus volts under operating voltage.
Yellow - 3 blinks	Shutdown	Disallows motion	Servo off	Toggle Enable input	Bus Under Operating Voltage Possible causes: Brown out, power supply undersized, Minimum Operating Bus Voltage set too high (this setting is in MSP under Advanced>Power and Temperature
Yellow - 4 blinks	Shutdown	Disallows motion	Servo off	Toggle Enable input	Command Speed Too High Probable cause: commanded speed/velocity is beyond motor spec.
Yellow - 4 blinks	Shutdown	Disallows motion	Servo off	Toggle Enable input	Tracking Error Limit Exceeded Possible causes: excessive friction, mechanical misalignment, vel/accel too high, low DC bus voltage.

Yellow - 4 blinks	Shutdown	Disallows motion	Servo off	Toggle Enable input	RMS Torque Limit Exceeded Possible causes: excessive friction, mechanical misalignment, duty cycle too high, undersized motor.
Yellow - 4 blinks	Shutdown	Disallows motion	Servo off	Toggle Enable input	Excessive Bus Current Probable cause: bad tuning, low bus voltage.
Yellow - 5 blinks	Shutdown	Disallows motion	Servo off	Toggle Enable input	Excessive Motor Temp Possible causes: ambient temperature too high for motor load, poor cooling, fan failure (if used), maximum temperature setting too low (this setting can be found under Advanced>Power and Temperature.
Yellow - 6 blinks	Shutdown	Disallows motion	Servo off	Toggle Enable input	Momentary Low Bus Voltage Power supply drooped below 18V, insufficient current capabilities, and/impedance too high.
Yellow - 7 blinks	Shutdown	Disallows motion	Servo off	Toggle Enable input	Old Config File Version Probable cause: Firmware updated after config file was saved. Create or load new config file.
Yellow - 7 blinks	Shutdown	Disallows motion	Servo off	Toggle Enable input	Motor Phase Overload Phase current is beyond allowed ADC limit. Probable cause: incorrect tuning or wrong config file.
Yellow - 7 blinks	Shutdown	Disallows motion	Servo off	Toggle Enable input	Hard Stop Gave Way A mechanical hard stop was detected during homing but it gave way before homing was completed.
Yellow - 7 blinks	Shutdown	Disallows motion	Servo off	Toggle Enable input	Excessive Bus Current Probable cause: bad tuning, low bus voltage.
Yellow - 7 blinks	Shutdown	Disallows motion	Servo off	Toggle Enable input	Commutation Startup Error DC bus too low for proper commutation start-up. Possible causes: brown out, incorrect power supply voltage, supply configured for higher AC line voltage.
Yellow - strobe	Shutdown	Disallows motion	Servo off	Toggle Enable input	Velocity Set Too High Velocity/speed limit exceeds motor's factory-set maximum speed.
Yellow - strobe	Shutdown	Disallows motion	Servo off	Toggle Enable input	RAS Change Rejected Unexpected error. Contact Teknic for work-around or new firmware.
Yellow - strobe	Shutdown	Disallows motion	Servo off	Toggle Enable input	Step Input Timing Error Possible causes: Step input pulse width too short, electrical noise, loose or shorted wires. A pull-up resistor may be required. Read Step Timing section of user manual for details.

Yellow - strobe	Shutdown	Disallows motion	Servo off	Toggle Enable input	Speed Too High For RAS Unexpected error. Contact Teknic for work-around or new firmware.
Yellow - strobe	Shutdown	Disallows motion	Servo off	Toggle Enable input	MagAlign Distance Error Distance traveled does not match expected value. Possible cause: motor against an end stop, incorrect motor settings.
Yellow - strobe	Shutdown	Disallows motion	Servo off	Toggle Enable input	MagAlign Direction Error Direction traveled is incorrect. Probable cause: external forces during MagAlign procedure.
Yellow - strobe	Shutdown	Disallows motion	Servo off	Toggle Enable input	DSP Watchdog Restart Firmware problem. Re-flash firmware with same or newer firmware version. Return unit to Teknic if problem not solved.
Green/Yellow alternating	Lockdown	Disallows motion	Servo on	Toggle Enable input	Travel Limits Violated (lockdown) Commanded position is on the wrong side of the home position.
Green/Yellow alternating	Lockdown	Disallows motion	Servo on	Toggle Enable input	Travel Limits Violated (lockdown) Commanded position is beyond the Max Travel from Home position as specified in Homing Setup.
Green/Yellow alternating	Lockdown	Disallows motion	Servo on	Toggle Enable input	Motor Enable Conflict The hardware inputs did not match the active software override inputs when the motor was enabled via the hardware enable line.
Green – 2 blinks	Warning	Allows motion (if cause is no longer present)	Servo on	Auto-clears at start of next move if cause is no longer present	Travel Limits Violated (warning) Commanded position is on the wrong side of the home position.
Green – 2 blinks	Warning	Allows motion (if cause is no longer present)	Servo on	Auto-clears at start of next move if cause is no longer present	Travel Limits Violated (warning) Commanded position is beyond the Max Travel from Home position as specified in Homing Setup.
Green – 2 blinks	Warning	Allows motion (if cause is no longer present)	Servo on	Auto-clears at start of next move if cause is no longer present	Move Buffer Underrun Possible causes: move increments too small or sent too slowly.
Green - 3 blinks	Alert	Allows motion	Servo on	Auto-clears when cause is no longer present	Torque Saturation Power supply may be insufficient for application, torque Limit may be set too low for command. Try lowering acceleration.
Green - 3 blinks	Alert	Allows motion	Servo on	Auto-clears when cause is no longer present	Voltage Saturation Available torque is limited by DC bus voltage. Commanded speed may exceed motor spec. Try lowering speed or using a higher voltage power source (if possible).

Green - 3 blinks	Alert	Allows motion	Servo on	Auto-clears when cause is no longer present	Over Speed Commanded speed exceeds motor max speed limit. Try lowering speed.
Green - 3 blinks	Alert	Allows motion	Servo on	Auto-clears when cause is no longer present	Over Temp Internal electronics above shutdown threshold. Add fan.
Red Toggle	Motor Failure	Disallows Motion	Servo off	Not clearable	Motor Has Failed Return to Teknic for repair or replacement.

If ClearPath shows no LED activity

During operation, if ClearPath DC bus voltage droops below approximately 18VDC, the following will occur:

- ClearPath will go into a shutdown state.
- The LED will turn off. Note: ClearPath will continue to communicate if voltage remains high enough.
- The LED will remain off. Toggling the Enable *will not* clear this shutdown.

Once voltage returns to approximately 20VDC or higher:

- ClearPath will remain in a shutdown state but the LED will “wake up” and flash a yellow blink code 6 (see table above for complete description of this exception code).
- At this point, toggle the enable to clear the shutdown.

APPENDIX B: MECHANICAL INSTALLATION

MOUNTING DIMENSIONS: POWER4-HUB

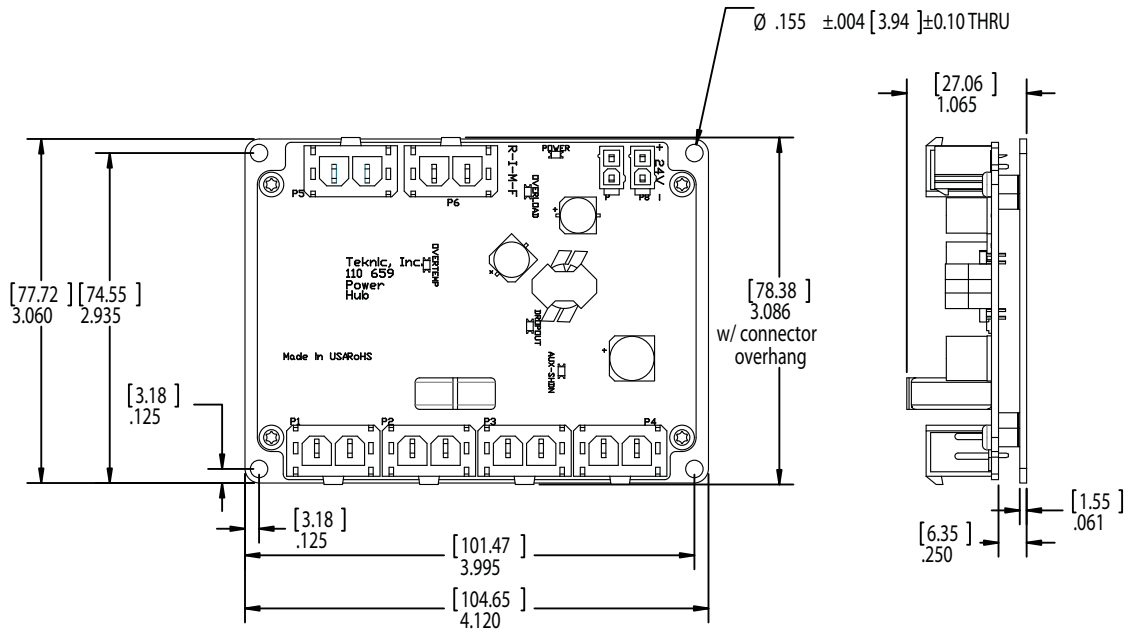

POWER4-HUB Mounting Dimensions

MOUNTING DIMENSIONS: CLEARPATH NEMA 34

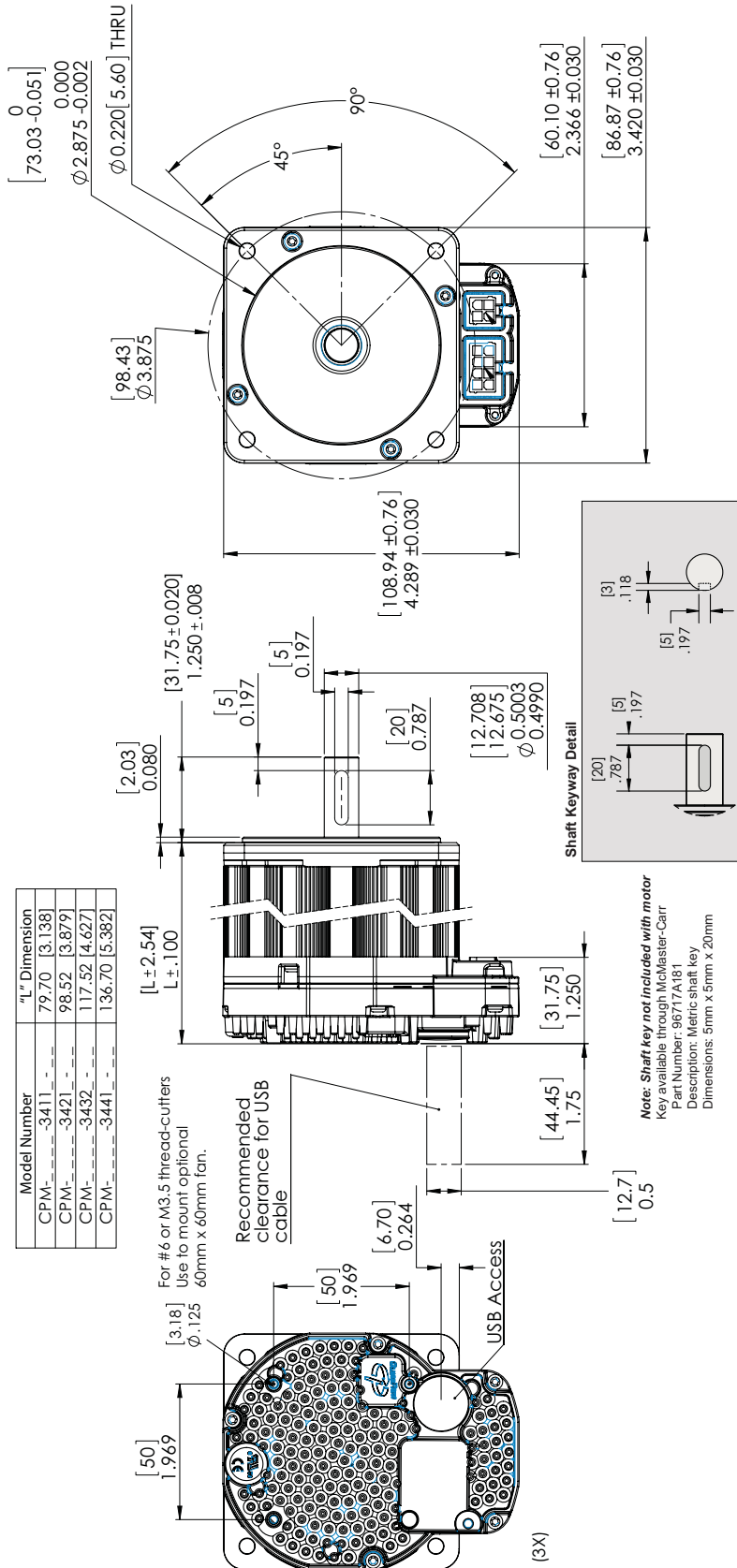

MOUNTING DIMENSIONS: CLEARPATH NEMA 23

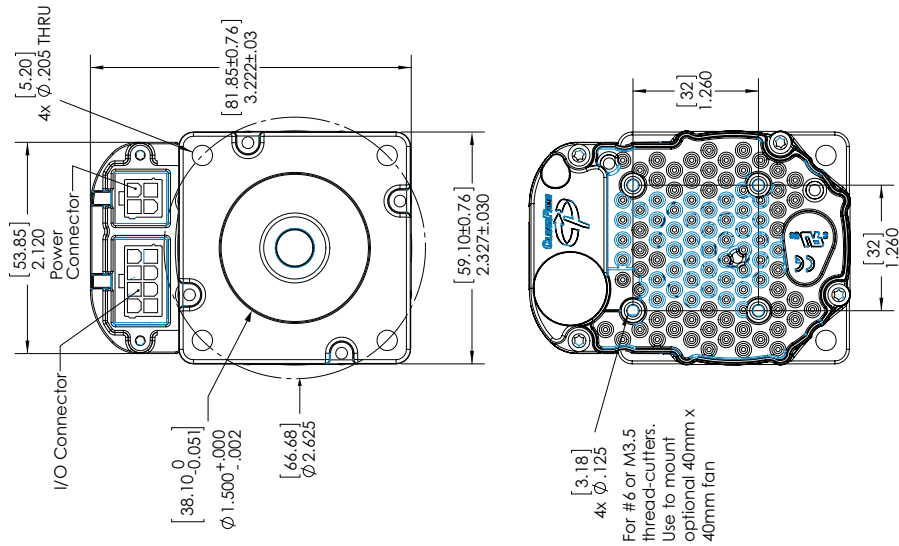

Model Number	"L" Dimension
CPM-2310	84.81 [3.339]
CPM-2311	84.81 [3.339]
CPM-2321	103.83 [4.088]
CPM-2331	122.83 [4.834]
CPM-2341	141.83 [5.584]

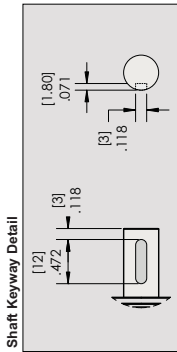

Note: Shaft key not included with motor
 Key available through MillMaster-Cair
 Part Number: 36717A086
 Rescription: Metric Shaft Key
 Dimensions: 3mm x 3mm x 10mm

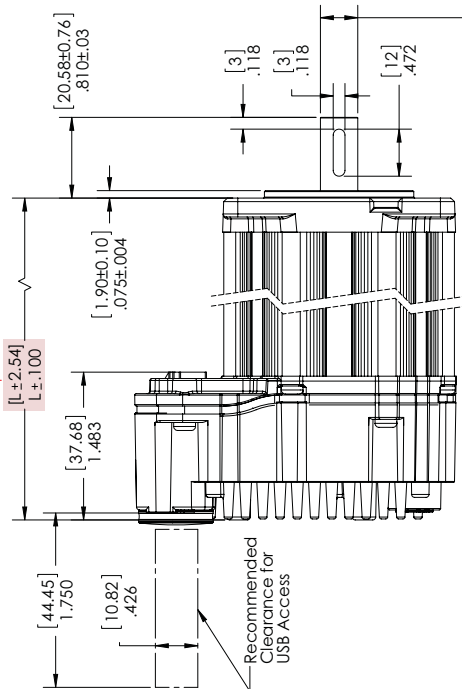

Optional 1/4" Full Round Shaft

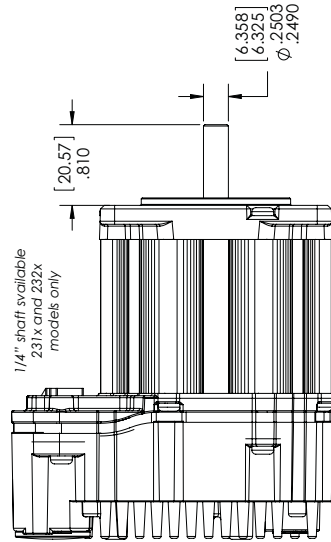

1/4" shaft available
 231x and 232x
 models only

MOTOR MOUNTING CONSIDERATIONS

Tip: Teknic recommends mounting the motor such that the USB port and status LED are visible and accessible when the motor is mounted to the machine.

- **Do not** mount ClearPath over a heat source such as a power supply, spindle drive, etc. ClearPath will automatically shut down if its internal temperature exceeds specifications.
- **Do not** mount ClearPath in an unventilated enclosure.
- **Do** allow for at least 1” of space around each ClearPath.
- ClearPath can be fitted with an external accessory fan if desired. See **Fan Mounting and Cooling** later in this section for details.

CONNECTING CLEARPATH TO A MECHANICAL SYSTEM

While it's obvious that ClearPath must be connected to a mechanical system to do useful work, it's not always clear just how to connect the motor to the mechanics.

Problems arise when a connecting element (such as a coupling) slips, exhibits excessive backlash, or can not accommodate typical shaft-to-shaft misalignments. Ultimately, the choice of shaft interface or coupling depends on the application, whether a precision positioning stage or a low speed conveyor.

The shaft interface (coupling, pulley, pinion, etc.) must be securely clamped to the shaft with minimum backlash (ideally none). This primary mechanical interface is critical in achieving and maintaining the best possible performance from a servo motion system.

MOTOR CONNECTION: GENERAL TIPS AND GUIDELINES

- **Align with care.** When connecting two shafts—such as a motor shaft to a screw shaft—the rotating centers must be carefully aligned in both the angular and offset sense (including offsets/adjustments for thermal growth) to achieve the best possible motion quality and longest motor/bearing life.

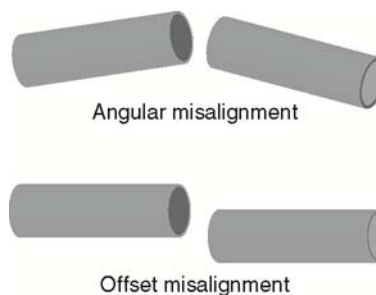

Some couplings are more forgiving of misalignment than others, but in general, misalignment will cause undesired vibration/noise, shortened bearing life, and even broken motor shafts.

- **Use lightweight components.** Aluminum couplings, pinions, and pulleys add significantly less inertia to the motion system than steel parts of the same size. In most applications, lower inertia is preferable because it allows the motor (and attached mechanics) to accelerate harder and move and settle faster.
- **Avoid using set screws.** Coupling devices with set screws are prone to failure and often become the weak link when joining a motor to a load. Set screws deform the metal around the screw's point of contact, often resulting in a raised bur on the shaft that can make it hard to remove and replace the coupling element. Set screws also tend to slip and score the shaft.
- **Tip:** Couplings, pulleys and pinions with circumferential clamping mechanisms tend not to damage motor shaft, hold better, and are easier to replace than those that use set screws.
- **Clamp close to the motor.** For maximum performance, secure pulleys and pinions as close to the motor face as is practical. This effectively reduces the lever arm (and associated bearing load) for applications with a side load.
- **Don't over tighten belts.** Always read the belt manufacturer's guidelines for proper belt tension, but never exceed the ClearPath specification for maximum side load. Overly tight belts put undue stress on the motor shaft and bearing systems that can result in premature bearing and shaft failure.
- **Avoid using shaft keys when possible.** Although ClearPath includes a keyway feature on the shaft, Teknic does not generally recommend the use of keys. Keys tend to cause run-out and backlash errors, particularly in reciprocating, precision positioning motion applications.

However, keys *should be considered* for use in applications where coupling slip could result in a dangerous or hazardous condition. Also, key use may be appropriate for unidirectional applications (where the motor always spins in the same direction) as these applications are less prone to key-related lash problems.
- **Avoid direct loads.** In general, ClearPath motors are not designed for connection to direct loads (e.g. direct connection to a grinding wheel). However, direct connection may make sense if the load is of low-mass and balanced, as with small mirrors for laser applications.

NOTES ON COUPLING SELECTION

A complete coverage of the topic *Coupling Selection for Servo Applications* is beyond the scope of this document, but many articles and resources can be found on the web for those interested in learning more. Because there are so many different coupling styles and applications, selecting the “right” coupling for a particular application can be challenging.

General Guidelines for Coupling Selection

Teknic has a few guiding principles when it comes to coupling selection for servo applications. Keep in mind that these are rules of thumb and may not apply to every application. In general:

- **Don't** undersize the coupling. Understand how much torque your application requires and stay within the coupling manufacturer's specifications. Always leave reasonable engineering margin.
- **Don't** use set screw type couplings. They damage the motor shaft and tend to be less reliable over time than clamp style couplings.
- **Do** use clamp style couplings. These clamp around the circumference of the shaft at one or two points without deforming the shaft surface.
- **Don't** use rigid couplings—they are notoriously intolerant of misalignments.
- **Don't** use beam style (helical) couplings if vibration damping or torsional stiffness is critical to your application. Beam couplings tend to resonate/whine at higher speeds.
- **Don't** use any coupling that requires you to drill into, deform, or “pin” the motor shaft.

Coupling Recommendation

Teknic often recommends **zero-backlash curved jaw couplings** (commonly referred to as “spider couplings”) as a good choice for many servo applications. These couplings are moderately priced and widely available from well established manufacturers such as Ruland.



Curved Jaw (Spider) Coupling

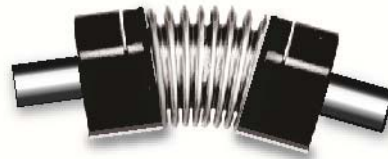

Bellows Coupling

Couplings for servo applications

Note: Curved jaw couplings (also known as spider couplings) are a good choice for many applications, but cannot tolerate a great deal of misalignment or axial motion. Also, never exceed the manufacturer's rating for “maximum torque with zero backlash” when using jaw couplings.

Bellows couplings are also excellent for high precision positioning applications. Bellows couplings allow for more misalignment than jaw couplings but are generally more expensive.

Both curved jaw and bellows coupling offer excellent positioning accuracy, high speed performance, and vibration damping when installed and operated within the manufacturer's specifications and guidelines.

Coupling Information on the Web

Ruland's website has a good collection of technical information on coupling types and coupling selection for servo systems. See links below.

<https://www.ruland.com/technical-resources/technical-articles>

<https://www.ruland.com/technical-resources/technical-articles/5-reasons-to-consider-using-jaw-couplings>

INSTALLING PULLEYS AND PINIONS

PULLEY AND PINION MOUNTING

- Always follow the manufacturers mounting guidelines.
- Mount pulleys and pinions as close to the motor face as possible while still following the manufacturer's installation guidelines.
- Never drill through, "pin", or deform the motor shaft when mounting a pulley or pinion.

Application Tip: To prevent loosening/slip, some users bond their pulleys and pinions to the motor shaft with a high strength adhesive such as Loctite #638. While this is very effective in preventing pulley slip, it can be difficult to undo once the adhesive has cured.

ABOUT END-OF-TRAVEL STOPS

End-of-travel stops are typically installed to prevent the moving element of a linear axis from flying off the machine in the event of a use or control error. There are a few common types of end stop to consider, but the final choice depends on the application objectives and requirements.

HARD BLOCKS

This is usually a solid block of steel, aluminum, or hard plastic secured at one or both ends of travel and positioned in such a way as to make even, repeatable contact with a hard surface on the moving element. Hard blocks are very effective at arresting motion, but can result in mechanical damage when struck at high speeds.

In several modes, ClearPath must home to a hard stop to establish a home reference position before functional positioning can begin.

ELASTOMERIC (RUBBER) STOPS

High durometer rubber stops (hard rubber) can also be used with applications that use HardStop Homing. This type of end stop offers a higher level of shock absorption and axis protection than hard blocks. Spongy, low durometer rubber stops are not recommended in most cases. They offer little benefit over a hard end stop during an axis crash.

PNEUMATIC (DASHPOTS)

Pneumatic hard stops (dashpots) offer excellent shock absorption performance but are considerably more expensive than hard blocks. Examples of specialized dashpots include the hydraulic cylinder in an automobile shock absorber as well as many automatic door closers.

END STOPS AND HARD STOP HOMING

End stops from medium durometer rubber to steel can be used successfully with Hard Stop Homing. When selecting end stops for a Hard Stop Homing application consider the following:

- Axes with low friction that are easily back driven can tolerate “softer” rubber end stops and still achieve good homing performance.
- Higher friction applications and those that cannot be back driven will generally require harder end stop material to achieve best Hard Stop Homing performance.
- Be prepared to test and experiment with different end block materials to ensure proper homing operation with your mechanical system.

FAN MOUNTING AND COOLING

All ClearPath motors have unthreaded mounting bosses on the rear casting to accommodate a standard DC fan (60mm for NEMA 34 motors, or 40mm for NEMA23 size motors). See the diagram below for mounting dimensions, hardware and supported fan sizes. Teknic does not sell accessory fans, but they are readily available through electronics suppliers including Digikey and Mouser.

Note: As with all electronic products, *cooler is better* for longest life span. So, even though ClearPath can reliably operate at elevated temperatures (exceeding the ratings of most other motor drives) your system should always be designed with the best cooling you can reasonably provide.

Note: ClearPath will shut down to self-protect when the rear cover temperature reaches 80 degrees C.

ClearPath NEMA 34

Designed for 60mm fans rated at **11 CFM** or greater

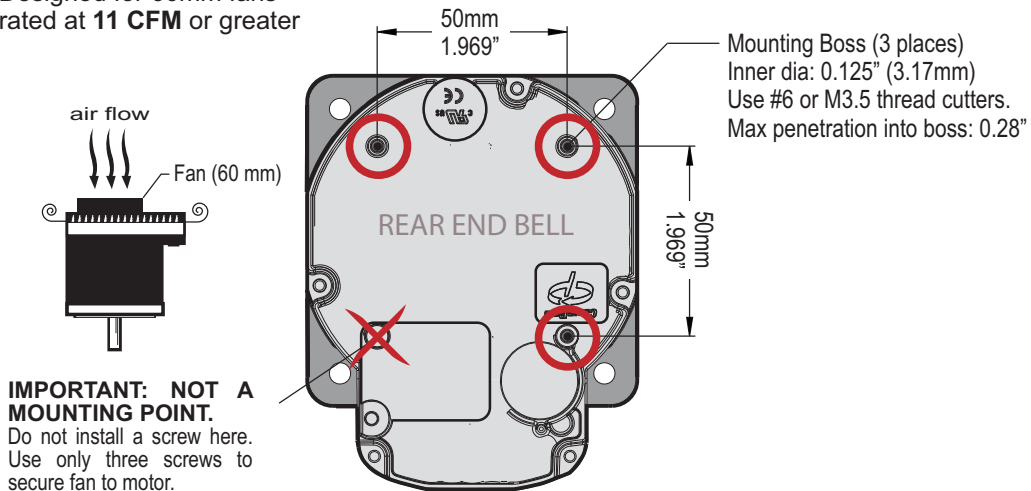

ClearPath NEMA 23

Designed for 40mm fans rated at **5 CFM** or greater

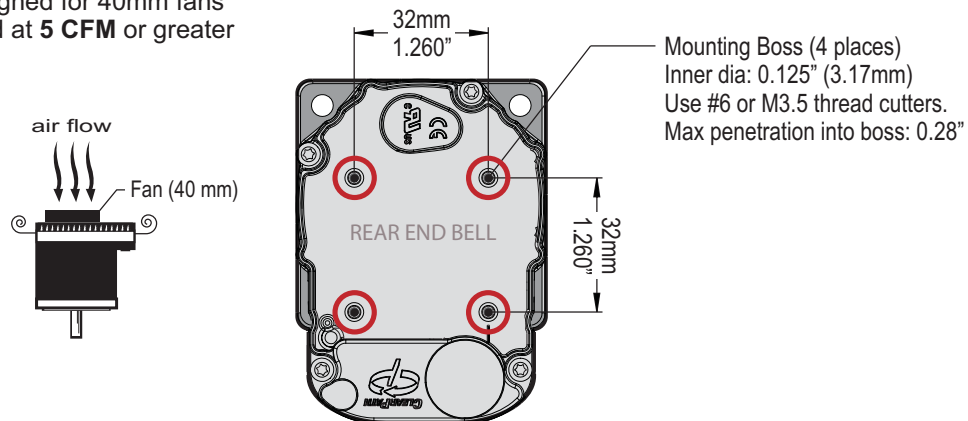

APPENDIX C: MATING CONNECTORS AND CABLE PINOUTS

MATING CONNECTOR INFORMATION

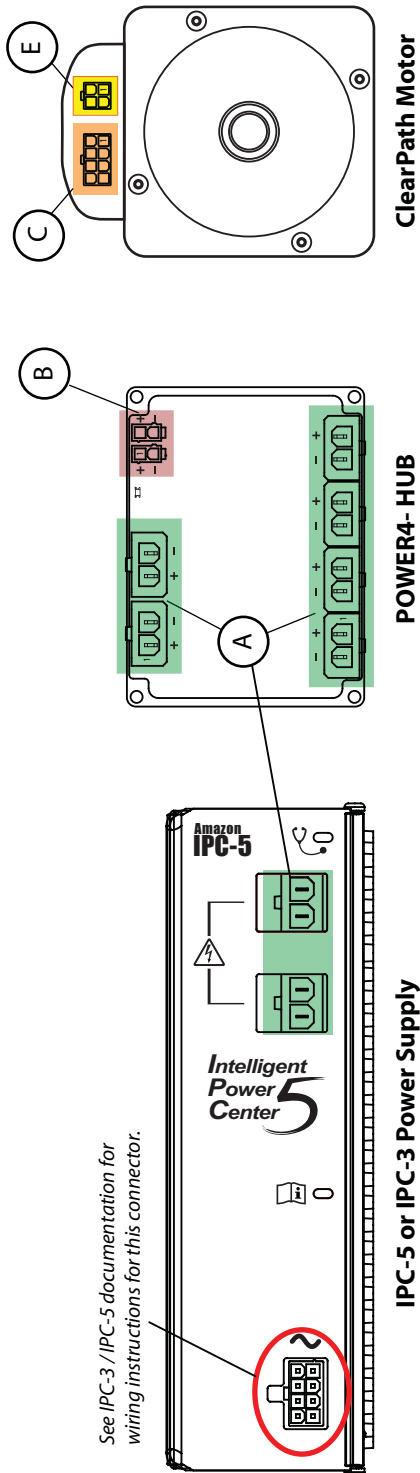

Parts listed in table manufactured by Molex Inc. Visit www.molex.com for complete specifications and application information.

Ref.	Description	Mating		Terminal PN	Terminal Desc.	Crimp Tool	Extraction Tool	Recommended Wire Gauge ¹
		Connector PN	Terminal PN					
A	Molex Sabre, Receptacle, 2 circuits	44441-1002 (natural, UL 94V-2) 44441-2002 (black, UL 94V-0)	43375-0001	Female crimp terminal, tin plate, 14-16 AWG	63811-7200 (14-16 AWG)	63813-2700		16 AWG
B	Molex MiniFit-Jr, Receptacle, 2 circuits	39-01-2020 (natural, UL 94V-2) 39-01-3025 (black, UL 94V-2) 39-01-3028 (natural, UL 94V-0) 39-03-9022 (black, UL 94V-0)	39-00-0059 (reel) 39-00-0060 (loose)	Female crimp terminal, tin plate, 18-24 AWG	63819-0901 (18-24 AWG)	11-03-0044		20 AWG
C	Molex MiniFit-Jr, Receptacle, 8 circuits	39-01-2080 (natural, UL 94V-2) 39-01-3085 (black, UL 94V-2) 39-01-2085 (natural, UL 94V-0) 39-03-9082 (black, UL 94V-0)	39-00-0046 (reel) 39-00-0047 (loose)	Female crimp terminal, tin plate, 22-28 AWG	63819-1000 (22-28 AWG)	11-03-0044		22 AWG
D								
E	Molex MiniFit-Jr, Receptacle, 4 circuits	39-01-2040 (natural, UL 94V-2) 39-01-3045 (black, UL 94V-2) 39-01-2045 (natural, UL 94V-0) 39-03-9042 (black, UL 94V-0)	39-00-0077 (reel) 39-00-0078 (loose)	Female crimp terminal, tin plate, 16 AWG	200218-2200 (16 AWG)	11-03-0044		16 AWG

¹AWG values listed are the actual wire gauges used in Teknic-manufactured cables.

CABLE PINOUTS

CONTROL CABLE: CPM-CABLE-CTRL-MU120

Cable description: ClearPath I/O connector cable, ~122 inches end-to-end. Overmolded Molex MiniFit Jr. 8-position connector to standard MiniFit Jr. 8-position connector (no overmolding on one end for easy access to wires).

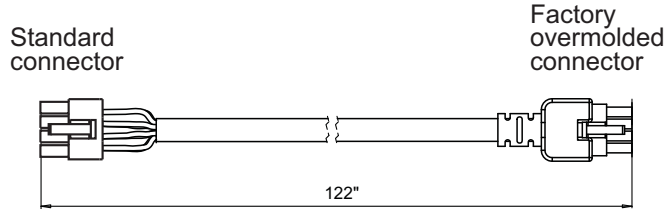

Pin Assignments		
Pin	Color	Name
1	GRN	HLFB +
2	BLK	Input B +
3	WHT	Input A +
4	BLU	Enable +
5	RED	HLFB -
6	YEL	Input B -
7	BRN	Input A -
8	ORN	Enable -

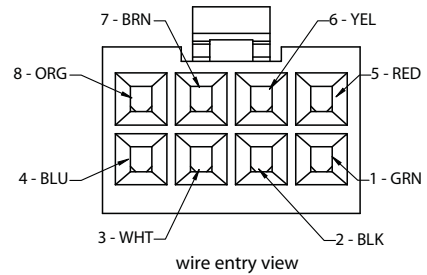

CONTROL CABLE: CPM-CABLE-CTRL-MM660

Cable description: ClearPath I/O connector cable (double-ended), ~662” end-to-end. Overmolded Molex MiniFit Jr. 8-position connector to same. Use “as is” or cut in half to make two cables with flying leads.

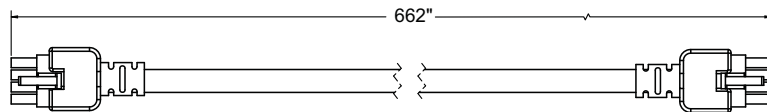

Pin Assignments		
Pin	Color	Name
1	GRN	HLFB +
2	BLK	Input B +
3	WHT	Input A +
4	BLU	Enable +
5	RED	HLFB -
6	YEL	Input B -
7	BRN	Input A -
8	ORN	Enable -

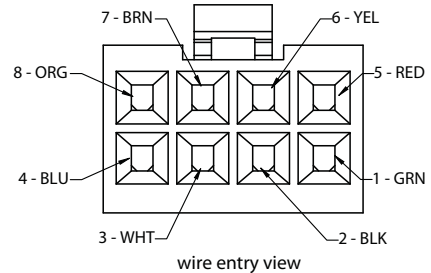

CONTROL CABLE: MOLEX BRAND (2 METERS AND SHORTER)

Molex stocks a few shorter, ClearPath-compatible control cables through their website (see URLs below).

Cable description: These cables are overmolded Molex MiniFit Jr. 8-position connector to same, with 18AWG wires. Available lengths include 0.5 meter, 1 meter, and 2 meters.

Note: The wire colors for the Molex brand cables are not identical to the wire colors used in the Teknic brand cables (listed on the previous page). This will not affect cable operation.

Length	Molex PN	Link
0.5 m	2451350805	https://www.molex.com/molex/products/part-detail/cable_assemblies/2451350805
1.0 m	2451350810	https://www.molex.com/molex/products/part-detail/cable_assemblies/2451350810
2.0 m	2451350820	https://www.molex.com/molex/products/part-detail/cable_assemblies/2451350820

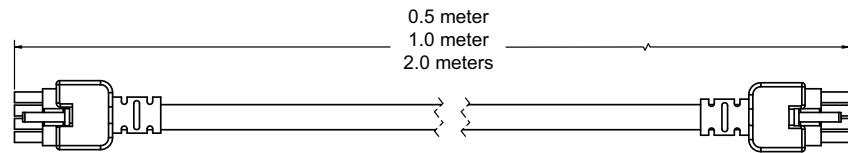

Pin Assignments		
Pin	Color	Name
1	BLK	HLFB +
2	RED	Input B +
3	WHT	Input A +
4	GRN	Enable +
5	ORN	HLFB -
6	BLU	Input B -
7	YEL	Input A -
8	GRY	Enable -

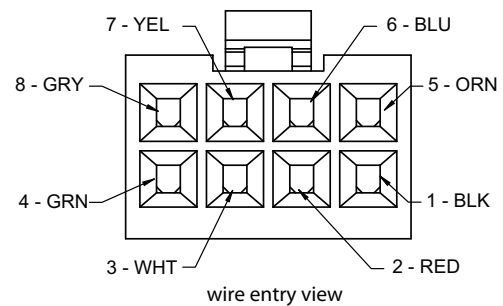

POWER CABLE: CPM-CABLE-PWR-MM660

Cable description: ClearPath power cable (double-ended). MiniFit Jr. 4-position connector to same. Designed to be cut in half (or as needed) to make up to two custom-length power cables with flying leads.

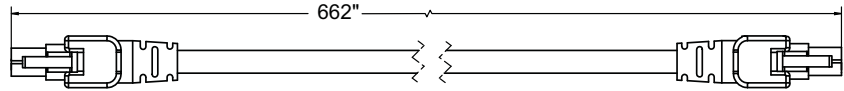

Pin Assignments		
Pin	Color	Name
2	BLK	GND
3	RED	V+

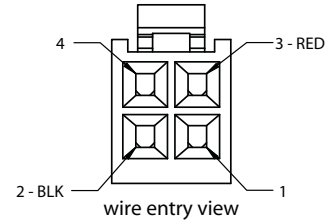

POWER CABLE: CPM-CABLE-PWR-MS120

Cable description: ClearPath power cable. This cable connects the DC output of a Teknic IPC-3 or IPC-5 power supply to the ClearPath power input connector. It features a Sabre 2-position connector to Molex MiniFit Jr. 4-position connector.

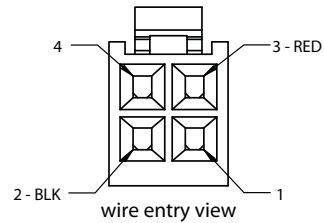
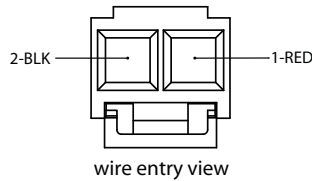
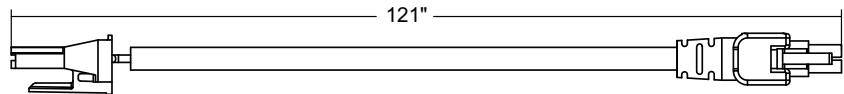

Pin Assignments		
Pin	Color	Name
1	RED	V+
2	BLK	GND

Pin Assignments		
Pin	Color	Name
2	BLK	GND
3	RED	V+

APPENDIX D: COMMON SPECIFICATIONS

Electrical Power Requirements:

Supply Voltage, Typical:	24VDC to 75VDC
Supply Voltage, Absolute Min:	21.5VDC (as measured at input terminals)
Supply Voltage, Absolute Max:	90VDC (as measured at input terminals)
Continuous Bus Current, Typical:	1A to 4A (application dependent)
Continuous Bus Current, Maximum:	10A
Idle Power usage from Bus	4W (enabled, no torque used by axis or load) 3W (disabled)

Electrical I/O:

Logic Input Voltage Range:	4.0VDC to 28VDC
Input Current @ 5V:	7.5mA (min.)
Input Current @ 28V:	12.0mA (min.)
HLFB Absolute Maximum Voltage	30VDC (across output terminals)
HLFB Output Current, Maximum:	9mA (non-inductive load)
HLFB Output voltage drop @ 2mA:	0.30VDC (+/- 100mV)
HLFB Output voltage drop @ 5mA:	0.55VDC (+/- 100mV)

Motor Bearing, NEMA34:

Maximum Radial Load, NEMA34:	220N (50-lbs), applied 25mm (1.0in) from front bearing
Maximum Thrust Load, NEMA34:	44N (10-lbs)
Bearing Life, NEMA34:	2.4×10^9 to 5.3×10^9 revs (typ., load dependent.)

Motor Bearing, NEMA23:

Maximum Radial Load, NEMA23:	110N (25 lbs), applied 25mm (1.0in) from front bearing
Maximum Thrust Load, NEMA23:	22N (5 lbs)
Bearing Life, NEMA23:	3.2×10^9 to 5.0×10^9 revs (typ., load dependent.)

Environmental:

Shock (peak, maximum):	10G (applied no more than twice)
Vibration (RMS, 2 Hz-200 Hz):	1.0G or 0.5mm, whichever is less
Maximum External Shaft Deceleration:	$250,000 \text{ rad/s}^2$
Ambient Temperature ⁴ :	-40°C to +70°C
Maximum Body Temp.:	100°C
Maximum Rear Cover Temp.:	70°C
Humidity:	0% to 95%, Non-Condensing
Recommended Optional Fan, NEMA23:	40mm square, 45.25 mm bolt center, ≥ 5 CFM
Recommended Optional Fan, NEMA34:	60mm square, 70.71 mm bolt center, ≥ 11 CFM

Environmental Sealing:

Front Face, with shaft seal option:	IP65
Front Face, without shaft seal option:	IP53
Body/rear, with dielectric sealing grease in connectors	IP55
Body/rear, no sealing provisions	IP53

Compliance:

Regulatory Certifications:	UL recognized, CE, RoHS
Electrical Safety:	UL508C, EN 61010-1
EMI:	EN 61326-1

Country of Origin:

USA

Warranty:

3 years

⁴ The RMS torque limit on certain motors is derated for operation in ambient temperatures above +40°C. Contact Teknic for derating assistance.

APPENDIX E: GROUNDING AND SHIELDING

PROTECTIVE EARTH (PE) CONNECTION

Compliance Note: ClearPath must be properly connected to the machine's Protective Earth terminal to meet EMC emissions specification EN-61000-6-4, and EMC immunity specification EN-61000-6-2, as well as EMC electrical safety specification EN-61010 (for CE/UL compliance).

Connect ClearPath to your machine's Protective Earth terminal (PE) using one of the following methods.

- **If the motor mounting plate is bonded to machine PE (typical)**, most of the work is already done. Simply secure ClearPath to the mounting plate with conductive fasteners (don't use anodized or coated hardware). Ensure direct, bare metal-to-metal contact between the ClearPath motor face and mounting surface.
- **If the motor mounting plate is not bonded to machine PE** it's still easy to make a good PE connection. Just install a grounding wire from ClearPath's Auxiliary PE Connection Point (located on the motor's rear casting) to a point on the machine that is bonded to machine PE. Use **#6-32, thread forming screw, 5/16" length** (McMaster-Carr PN 93878A145). Use grounding wire with same AWG number (or heavier) as the ClearPath DC power input wiring.

Note: In scenarios where ClearPath is *not* connected to a PE (Protective Earth) return path—such as during bench testing or maintenance—temporary grounding measures may be necessary to comply with safety requirements.

GROUNDING AND SHIELDING

- Always maintain separation between isolated control ground and power ground.
- Shielded cable is not required for ClearPath control cables.
- If you choose to use shielded control cable, connect the cable's isolated ground at one point (at the controller only). Do not hook isolated control ground to the machine frame or chassis at any other location.
- Do not ground ClearPath I/O circuits to the machine frame or chassis.

Note: All ClearPath I/O signals are electrically isolated from ClearPath's DC power input and motor output circuits, as well as from the motor case. This design feature helps to ensure that control signals aren't compromised by induced currents from the motor, power supply, or internal PWM.

POWER RETURNS

- Never use the machine frame or chassis as a power return. Use discrete cable or wires for all power wiring.
- Use only recommended wire gauge (16-18AWG typical) for all ClearPath power wiring. When in doubt, use heavier wire.

APPENDIX F: CIRCUIT SCHEMATICS

POWER4-HUB SCHEMATIC (SIMPLIFIED)

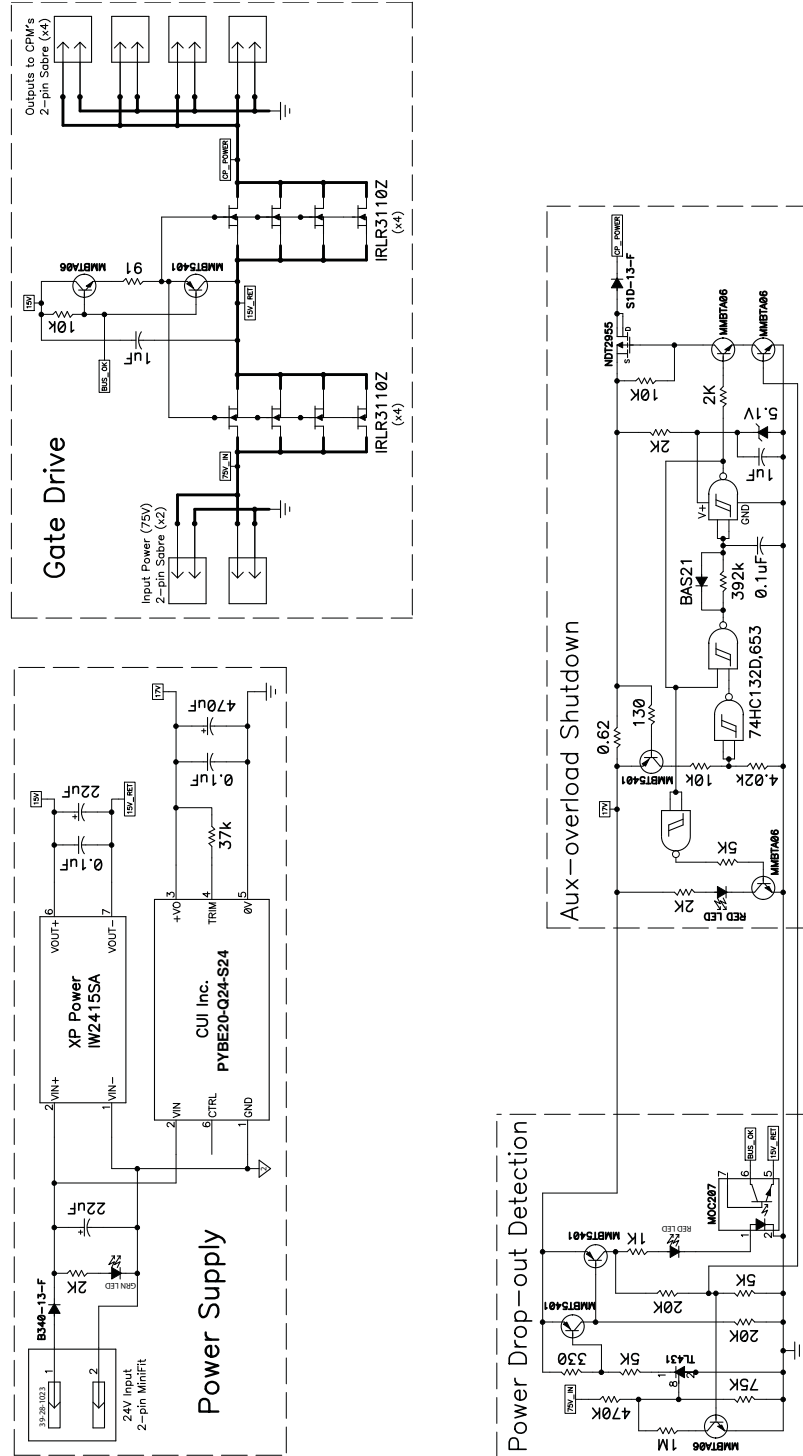

POWER4-HUB simplified schematic

APPENDIX G: CLEARPATH PART NUMBER KEY



1	Product ID	CPM	ClearPath® Motor
2	Family/Model	SDSK	Step & Direction / "Stepper Killer" (2-3x the power of a similarly sized stepper)
		SDHP	Step & Direction / High Power model (8-15x the power of a similarly sized stepper)
		MCVC	Motion Controller / Velocity, Torque, 2 Position Modes
		MCPV	Motion Controller / Position, Velocity, Torque Modes
		SCSK	Software Control / "Stepper Killer" (3x the power of similarly sized steppers)
3	Motor Frame Size	23	NEMA 23 frame
		34	NEMA 34 frame
4	Body Length <i>Approximate, excludes shaft length</i>	1	82mm
		2	100mm
		3	120mm
		4	140mm
5	Winding/Magnetic Structure	0	
		1	
		2	Indicates specific winding design. See your motor's torque-speed curve for more information.
		5	
		6	
6	Winding Type	S	Series-Wye (higher torque, lower speed)
		P	Parallel-Wye (in between S and D characteristics)
		D	Parallel-Delta (higher speed, lower torque)
7	Enhanced Options	R	Positioning Resolution = 800 counts per rev. (<i>g-Stop supported on MCPV models ending in Exx</i>)
		E	Positioning Resolution = 6400 counts per rev.
8	Shaft Diameter	L	Standard (NEMA 34 = 1/2", NEMA 23 = 3/8")
		Q	1/4" shaft diameter (<i>available only on NEMA 23 models with body length 1 or 2</i>)
9	Shaft Seal	N	Standard dust sealing
		S	Extra PTFE infused polyimide seal. Not available on 1/4" shaft models.
10	Feature Set SC Models Only	B	Basic features; see list below.
		A	Advanced features; see list below.

Basic Features-SC models only

- Velocity moves
- Global torque limit
- HardStop foldback (homing)
- Trapezoidal moves
- Node stops / e-stops
- Reading and modifying positions
- RAS™ (jerk limiting)
- Status register
- Warning and alert system
- Parameter memory
- Safety shutdowns
- Soft limits
- User defined data
- Automatic brake coil control
- Group shutdowns

Advanced Features-SC models only (Includes all Basic Features)

- RAS™ & g-Stop™ (jerk limiting & vibration suppression)
- Positive and Negative torque limiting
- Triggered moves (on input or command, including move groups)
- Head-tail moves
- Asymmetric moves
- A-after-start event generation
- B-before-end event generation
- Conditional torque limiting
- Attention generation
- Position capture

APPENDIX H: MISCELLANEOUS TOPICS

HOMING

INTRODUCTION

Why Home? In many servo positioning applications, the moving element of the stage (i.e., the load) must be precisely positioned at a known location along the stroke of the axis before accurate positioning can begin. This is where homing comes in.

When a ClearPath motor is powered up the motor does not know exactly where its load is positioned along the stroke. Thus, if an application requires the load to be in a specific location before operations begin, the motor must be homed.

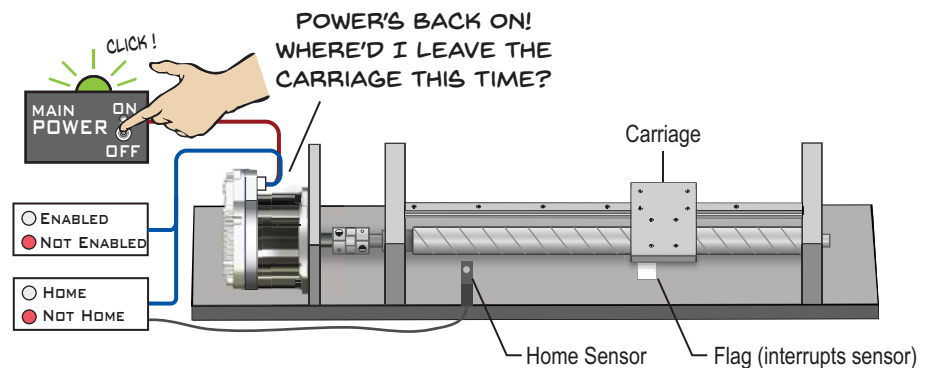

HOMING (OVERVIEW)

The homing process typically involves moving the motor in a predetermined direction towards a physical home location (typically a sensor or hardstop at the end of travel).

When the motor arrives at this location, the position is recorded, and the motor moves to a predefined offset location. Once at the offset position, the motor will begin to operate normally as defined by the currently selected operating mode.

This process ensures that an application will always begin in the same physical location regardless of the motor's position upon power-up.

TERMS USED IN THIS SECTION

Please read the below definitions to familiarize yourself with a few frequently used ClearPath homing terms.

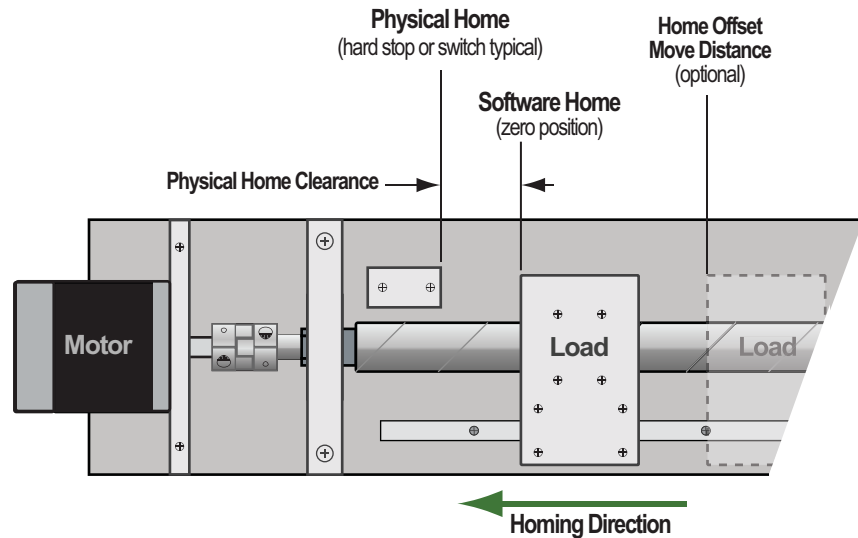

Physical Home - Physical Home is the position of a mechanical hardstop or home sensor. When the Physical Home is encountered, e.g. a homing switch is actuated, the position is recorded, and the ClearPath motor stops and moves away towards the final offset position.

Software Home (zero position) - During homing, once the Physical Home (sensor or hard stop) is detected, ClearPath's position counter is adjusted such that the Software Home (zero position) is a user defined distance from the Physical Home

Physical Home Clearance (setting) - This is the user-defined distance between Physical Home and Software Home (in encoder counts). Physical Home Clearance provides safety spacing between the load and Physical Home. The default setting is 1 motor revolution.

Home Offset Move Distance (setting) - This is an additional, user-defined parameter which determines the final offset location when homing is completed. At the end of homing the load will be the specified distance away from the Software Home.

HOMING SETTINGS

Homing dialog settings are explained below.

HOMING SETTINGS: COMMON TO ALL MODES

These homing settings are common to all ClearPath Automatic Homing setups. They tell ClearPath the basics of when, where, and how to home.

The screenshot shows a dialog box with three sections:

- Homing Occurs...**: Two radio buttons. The first is selected: "Upon first Enable after power-up (or motor reset)". The second is "Upon every Enable".
- Homing Direction**: Two radio buttons. The second is selected: "CW (Clockwise) (-)". The first is "CCW (Counter-clockwise) (+)".
- Homing Move Settings**: Two input fields. The first is labeled "Speed (RPM)" and contains the value "200". The second is labeled "Accel/Decel (RPM/s)" and contains the value "1,500".

Homing Occurs...

Lets you specify when to home your axis, either 1) the first time ClearPath is enabled after power up (typical), or 2) every time ClearPath is enabled.

Application Note: If your ClearPath has Logic Power Back-up, *and* you select "Homing Upon first Enable after power-up", you must cycle both power sources (main DC and Logic Power) before homing will be allowed.

Homing Direction

Lets you choose clockwise or counter-clockwise shaft rotation during homing. Select the direction of motor shaft rotation that will move the load toward the Physical Home (hard stop, switch, sensor).

Homing Move Settings

Lets you specify homing speed and acceleration. **Caution:** always test homing operation at low speed and acceleration.

HOMING SETTINGS: OTHER

Homing Torque Limit (Hard Stop Homing only)

Homing Torque Limit

Torque Limit Used During Homing (% of max)

When homing is initiated, ClearPath lowers the torque limit to this value. The Main Torque Limit is automatically restored after homing is complete.

Switch Polarity (Home To Switch only)

The Switch Polarity checkbox gives you the option of inverting how ClearPath interprets the home switch input state. This is helpful, for example, if you have a normally closed home switch and you really needed a normally open switch.

Switch Polarity

Invert Not In Home

Switch Polarity

Invert In Home Now

To test or change the Home Switch Polarity:

1. Actuate the home switch manually, i.e. close the switch or interrupt the sensor.
2. Read the status indicator from the homing dialog in MSP as shown above. If it reads "Not in Home" when the switch is actuated then click the Invert checkbox. "In Home Now" should display.
3. Release the home switch and verify that "Not in Home" is now displayed in the status indicator.

"Miscellaneous" Settings

Miscellaneous

Max Travel From Home (cnts)

Physical Home Clearance (cnts)

Home Offset Move Distance (cnts)

Max Travel From Home (cnts) - (Optional. Set to "0" to turn off.) This is a software enforced travel limit. It is the maximum distance that the motor is allowed to travel away from the Software Home position (i.e.,

the zero position). ClearPath will not execute any move that would violate this travel limit.

Physical Home Clearance (cnts) - This is the user-defined distance between Physical Home and Software Home (in encoder counts). It is intended to provide safety spacing between the load and Physical Home. Default setting is 1 motor revolution.

Home Offset Move Distance (cnts) - (Optional. Set to "0" to ignore.) This parameter determines the final position of the axis relative to the Software Home. If this parameter is set to zero, the motor will remain at the Software Home (zero) position when homing is complete.

Precision Homing

The Precision Homing feature was created to help ensure that ClearPath always finds the exact same Software Home (zero) position, even in cases where the hard stop or home switch has slipped, bent, or otherwise drifted in position. See the "Precision Homing" section later in this document for more information.

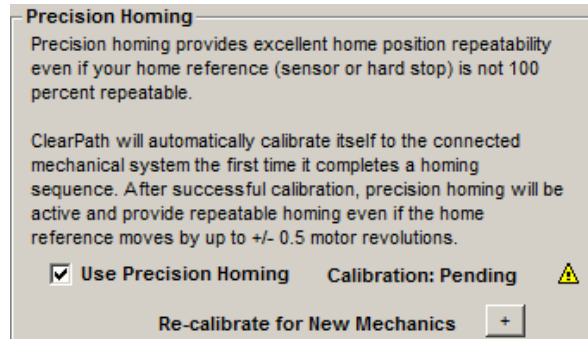

Precision Homing section of Homing Dialog

Shaft Angle Homing

This homing method was designed with a rotary axis in mind— a rotary tool changer for example. This method requires no additional sensor or end of travel hard stop to use.

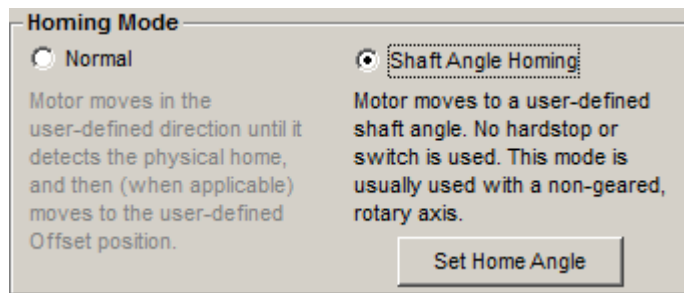

To use Shaft Angle Homing:

1. Select "Shaft Angle Homing" from the homing dialog (see image above).
2. Manually move the motor shaft to the desired position.
3. Click "Set Home Angle" button to store the shaft angle in the motor's memory. This setting will be retained in motor memory, even if main power to ClearPath is cycled.

Note: on first power-up, the motor may move more than 1 revolution before reaching the desired shaft angle.

Manual Homing aka "User Seeks Home"

Manual Homing is available in Step & Direction and Pulse Burst Positioning modes only.

When using Manual Homing, the user is responsible for sending homing moves to ClearPath via step and direction or pulse burst signals.

To use this feature, select the "**User Seeks Home**" setting in the homing dialog of Step and Direction or Pulse Burst Positioning mode.

See typical homing sequences section for more information on manual hard stop homing.

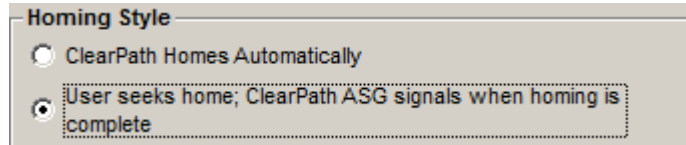

Advanced Settings

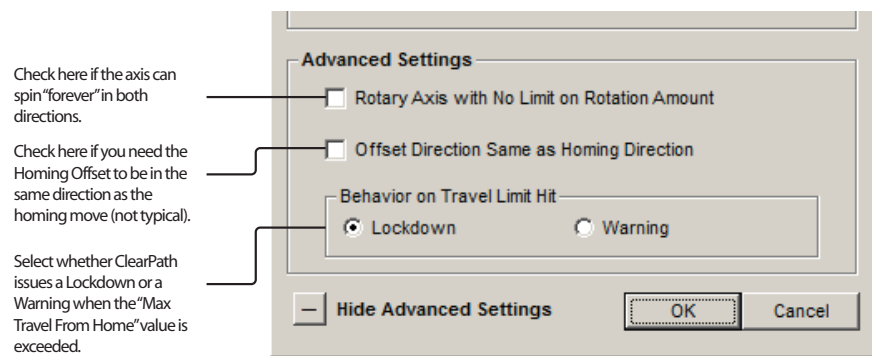

Homing: Advanced Settings

Rotary Axis with No Limit on Rotation Amount

Check this box if you have an axis such as a conveyor or turntable with unlimited travel in either direction.

Offset Direction Same as Homing Direction *(not commonly used)*

Check this box if you want the post-homing offset move to be in the same direction as the homing move. This setting is mainly used with rotary axes with unlimited bi-directional motion such as a turntable or conveyor.

Behavior on Travel Limit Hit

This setting tells ClearPath whether to issue either a Warning or a Lockdown (read note below) if you attempt to move past the "Max Travel from Home" setting described earlier.

Warning vs. Lockdown

A Lockdown disallows motion until you toggle Enable to clear it. The indicator LED on ClearPath flashes alternating yellow and green when a Lockdown occurs.

A Warning allows motion only in the direction away from the soft limit and the Warning automatically clears when the condition that caused it is no longer present. The indicator LED on ClearPath flashes a green 2-blink code when a Warning occurs.

TYPICAL HOMING SEQUENCES

This section enumerates the main steps involved in the most common ClearPath homing scenarios.

For the sake of discussion, we will assume that the ClearPath motor described in this section is set to **home every time it is enabled** (as opposed to homing only the first time it is enabled after power up).

AUTOMATIC SWITCH HOMING SEQUENCE

1. The user Enables ClearPath. (Enabling energizes the motor coils and puts ClearPath in Automatic Homing mode.)
2. ClearPath automatically moves the load toward Physical Home (a sensor) at the user-specified acceleration, speed, and direction.
3. The sensor is actuated. The point of actuation is defined as Physical Home. The Software Home (zero position) is defined to be the Physical Home Clearance away from the Physical Home.
4. The motor begins to decelerate.
5. The motor stops at some point past the sensor location (determine by homing velocity and deceleration).
6. ClearPath moves towards the offset location as defined by the [Home Offset Move Distance] parameter. If this value is zero, ClearPath moves to the Software Home (zero position).
7. Homing is complete. ClearPath can now act on motion commands.

AUTOMATIC HARD STOP HOMING SEQUENCE

1. The user Enables ClearPath. (Enabling energizes the motor coils and puts ClearPath in Automatic Homing mode.)
2. ClearPath automatically moves the load toward Physical Home (a hard stop in this case) at the user-specified acceleration, speed, and direction.
3. The load hits the hard stop, triggering the Hard Stop Detection algorithm. Holding torque against the hard stop is automatically rolled back.
4. Physical Home is established. This then defines the Software Home(zero position) to be the Physical Home Clearance away from the Physical Home.
5. ClearPath moves away from the Physical Home to the offset location specified in the [Home Offset Move Distance] parameter. If this value is zero, ClearPath moves to the Software Home(zero position).
6. Homing is complete. ClearPath can now act on motion commands.

MANUAL HARD STOP HOMING SEQUENCE

1. The user Enables ClearPath. (Enabling energizes the motor coils and puts ClearPath in Manual Homing mode.)
2. The motor remains stationary until the user's control system issues a move toward the Physical Home (hard stop) using Step & Direction or Pulse Burst signals. *Note: This initial move must be long enough to guarantee the load will hit the hard stop from the farthest point away from the stop.*
3. The load hits the hard stop, triggering the Hard Stop Detection algorithm. Holding torque against the hard stop is automatically rolled back.
4. If the motor's HLFB output is set to "ASG", the output asserts.
5. ClearPath waits for the user's controller to send pulses to command motion *away* from the hard stop. Any further commands into the hardstop are disregarded while the motor is folding back torque.
6. Upon seeing the first step or pulse away from the hard stop ClearPath's position counter is automatically zeroed. ClearPath exits homing mode and is ready for further move commands.

PRECISION HOMING

Precision Homing helps assure that your specified home position remains highly repeatable over time, even if the physical home mechanism (typically a switch, sensor or hard stop) takes a hit and shifts position, becomes bent, or experiences sensor drift over time. The physical home mechanism can move by as much as $\pm 1/2$ of a motor revolution and not affect axis homing repeatability.

Video Link: [Precision Homing Explained](#)

When a ClearPath motor is set up for Precision Homing, the motor automatically calibrates itself to the connected mechanical system the first time ClearPath completes a homing operation (note: homing can be recalibrated very easily at any time). After successful calibration, Precision Homing remains active unless the feature is turned off in MSP.

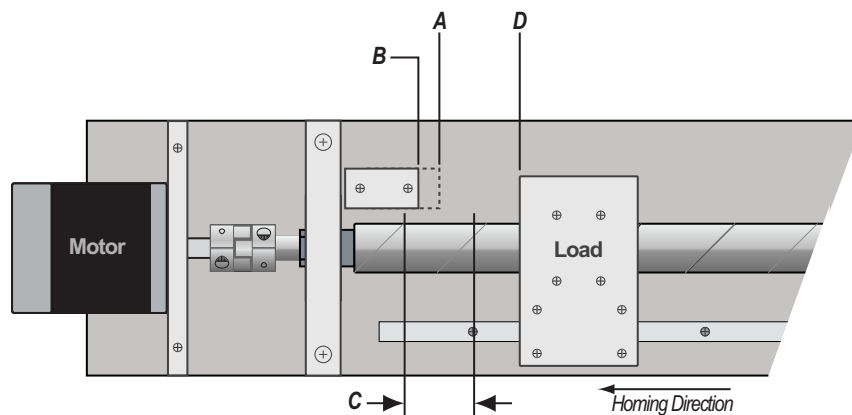

Precision Homing Nomenclature

- (a) **Original Physical Home** - This is the Physical Home reference *point found during the initial homing/calibration* operation. Note: This reference position is stored in the motor's NV memory. It is not reset if power is cycled.
- (b) **Current Physical Home** - This is the most recent Physical Home found. This position will only be different from Original Physical Home if the associated sensor or hard stop has moved or drifted.
- (c) **Max. Error Between Original (Calibrated) Physical Home and Current Physical Home.** Precision Homing will successfully complete as long as the Current Physical Home position does not exceed $\pm 1/2$ rev from Original Physical Home.
- (d) **Final Position** after homing is complete (defined by the Physical Home Clearance, and Offset Move Distance parameters).

PRECISION HOMING SETUP

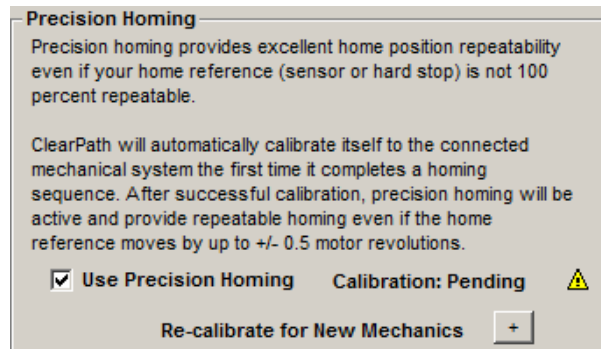

Precision Homing dialog in Homing Setup window

To calibrate ClearPath to your mechanics, you only need to complete one initial homing operation. Whenever you need to clear and reset calibration, click the (+) button as shown in the above screenshot and follow the prompts to clear the calibration.

Important: Any time a motor is connected to new or different mechanics, or is disassembled from its associated mechanics and reassembled, **you must clear the Precision Homing calibration data** to allow a new calibration to occur.

Manually clear the Precision Homing calibration data by doing one of the following:

- Press the “Clear Calibration...” button.
- Load a motor configuration file.
- Run Auto-tune.
- Reset the configuration to factory default settings. Once cleared, re-calibration will occur on the very next homing operation.

HOMING METHODS LISTED BY OPERATIONAL MODE

Sensor Homing is available in the following modes:

- Move to Absolute Position: 2 Positions (Home to Switch)
- Move Incremental Distance: 2 Increments (Home to Switch)
- Move Incremental Distance: 1 Increments (Home to Switch)
- Multiple Sensor Positioning: Rotary with Sensor Homing
- Follow Digital Position Command: Unipolar PWM Command
- Follow Digital Position Command: Frequency Command

Automatic Hard Stop Homing is available in the following modes:

- Move to Absolute Position: 4 Positions (Home to Hard Stop)
- Move to Absolute Position: 16 Positions (Home to Hard Stop)
- Move Incremental Distance: 4 Increments (Home to Hard Stop)
- Move Incremental Distance: 2 Increments (Home to Hard Stop)
- Pulse Burst Positioning
- Multiple Sensor Positioning: Linear
- Follow Digital Position Command: Unipolar PWM Command
- Follow Digital Position Command: Frequency Command
- Step and Direction

Manual Hard Stop Homing aka "User Seeks Home" is available in these modes:

- Pulse Burst Positioning
- Step and Direction

Shaft Angle Homing is available in the following modes:

- Move to Absolute Position: 4 Positions (Home to Hard Stop)
- Move to Absolute Position: 16 Positions (Home to Hard Stop)
- Move Incremental Distance: 4 Increments (Home to Hard Stop)
- Move Incremental Distance: 2 Increments (Home to Hard Stop)
- Pulse Burst Positioning
- Multiple Sensor Positioning: Linear
- Multiple Sensor Positioning: Rotary with Sensorless Homing
- Follow Digital Position Command: Unipolar PWM Command
- Follow Digital Position Command: Frequency Command
- Step and Direction

MSP MOTION GENERATOR

The Motion Generator in MSP allows you to quickly and easily jog and test your ClearPath motors (and any connected mechanics) with **no external switches or sensors required**.

With the Motion Generator you can:

- Manually enable your ClearPath motor
- Run point-to-point profiled moves at the velocity, acceleration, and distance of your choosing
- Jog your motor at different velocities and accelerations
- Manually toggle all of your motor's digital inputs
- Visually monitor the status of the motor inputs and HLFB output

To open the Motion Generator mode from the MSP main menu, select *Mode>Motion Generator*.

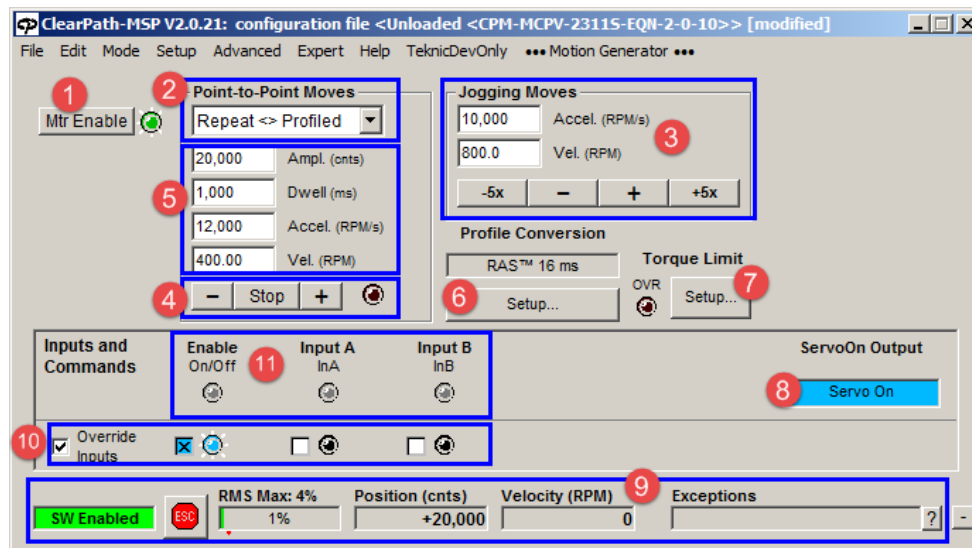

Motion Generator window

MOTION GENERATOR CONTROLS

1. Mtr Enable (Enable/Disable Button)

Use this button to enable and disable the motor. When ClearPath is enabled, the motor windings are energized and ready for commands.

2. Point-to-Point Move Type (drop down menu)

- **Single Profiled** - Move once and stop. Click + or - button to launch a single move in the specified direction.
- **Repeat <> Profiled** - Move back and forth repeatedly. Click + or - button to launch reciprocating (back and forth) moves.
- **Repeat >> Profiled** - Move repeatedly in the same direction. Click + or - button to launch repeating moves in the same direction.

3. Jog Controls - Jog your motor with a single click. Set acceleration and velocity as desired. Then, hold down (+) or (-) button to jog ClearPath; release to stop motion. Hold down the (+5x) or (-5x) button to jog ClearPath at 5 times the speed setting.

4. Move Start and Stop: Use these controls to start and stop a point-to-point move. The (+) button commands a move in the counterclockwise direction; the (-) button commands a move in the clockwise direction. Click the Stop button to end a move cycle. **Double-click the Stop button to stop motion immediately.**

5. Move Parameters: Define move parameters for Point-to-Point Moves here. These include move distance (Ampl.), Velocity (Vel.) Acceleration (Accel.), and pause time between repeating moves in milliseconds (Dwell).

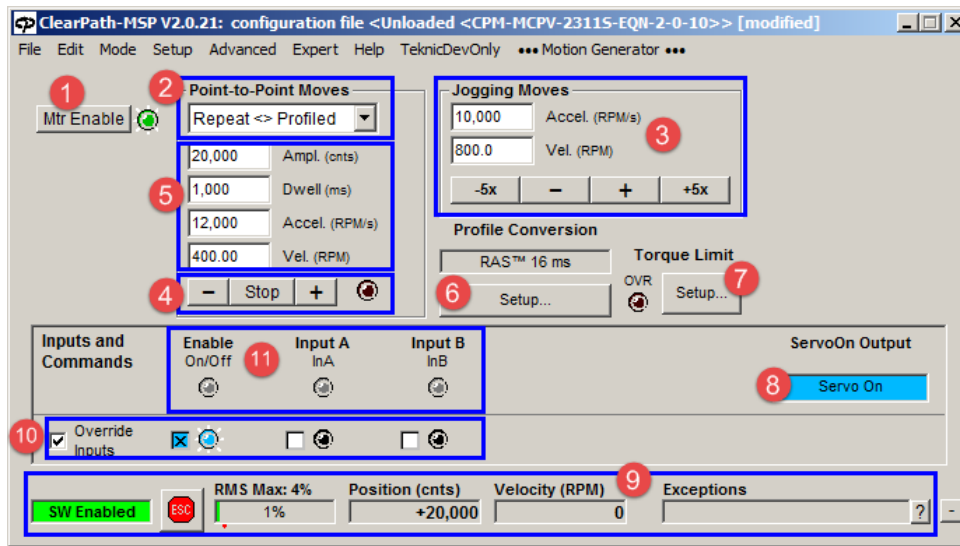

Motion Generator window (duplicate figure for reference)

6. g-Stop and RAS Setup: Opens the Profile Conversion dialog. Use this to set and test the effect of different g-Stop and RAS settings on your Motion Generator moves. For MC series motors, **the g-Stop feature is available only on MCPV models ending in -Exx (Enhanced models) for example: CPM-MCPV-2331S-ELN.**

7. Torque Limit Setup: Opens Torque Limit dialog.

8. High Level Feedback Readout: Displays status of ClearPath's digital output, HLFB (High Level Feedback).

9. Dashboard: Displays real-time motor information including enable state, RMS torque level, motor position, motor velocity, and exception information.

10. Software Control Override: Check the "Override Inputs" button to activate Soft Controls. Manually toggle the motor's inputs without an external hardware controller.

11. Input Status: Software LEDs that visually indicate the logic states of the Enable Input, Input A, and Input B.

ENCODER AND INPUT RESOLUTION

INTRODUCTION

This section includes a discussion of the following topics:

- ClearPath's Internal (native) Encoder Resolution versus Positioning Resolution.
- Understanding and using the Input Resolution setting for *Step and Direction* and *Pulse Burst Positioning* applications.

TERMS USED IN THIS SECTION

Count (or "encoder count")

A count is the smallest increment of encoder/shaft motion that can be commanded at a given encoder resolution. This family of ClearPath motors come in either 800 or 6400 counts per revolution. See *Positioning Resolution*, next page.

Step (also called "step pulse", or just "pulse")

A step is an electrical pulse sent from a controller, PLC, indexer, etc. to the ClearPath motor's step input as a means of commanding motion. One step pulse sent to the ClearPath Step Input tells ClearPath to rotate the shaft one increment of motion. If the step-to-count ratio is 1:1, then 1 step will command 1 count of motion.

Steps per count

This is just the number of step pulses required to move the motor shaft one count. This is often set at 1:1, but can be adjusted using the Input Resolution setting in MSP (covered later in this section).

Counts per step

This is the number of counts the motor shaft will move for each step sent to the ClearPath Step Input. This is often set at a 1:1 ratio, but can be adjusted using the Input Resolution setting in MSP (covered later in this section).

NATIVE RESOLUTION

ClearPath motors described in this manual are all equipped with an incremental rotary encoder with a native resolution of 12800 counts per revolution. This "internal" resolution is used by the motor's motion algorithms, and is one of the factors behind ClearPath's high precision, highly repeatable motion performance.

POSITIONING RESOLUTION

Positioning Resolution—also called "*Commandable Resolution*"—is the ClearPath motor's working encoder resolution. This is the encoder resolution you specified when ordering your ClearPath. The two available Positioning Resolution options for NEMA 23 and NEMA 34 ClearPaths are:

- **800 counts per revolution** for motor part numbers ending in **-Rxx**.
- **6400 counts per revolution** for motor part numbers ending with **-Exx**.

INPUT RESOLUTION SETTING IN MSP

Note: This topic applies to Pulse Burst Positioning and Step and Direction modes only.

The **Input Resolution** setting lets you vary the ratio of step pulses received by the motor to encoder counts moved. It is set via a drop down menu in the mode settings of *Pulse Burst Positioning* and *Step and Direction* modes.

Feature Note: Enhanced ClearPath motors (part# ends in -Exx) allow the user to set the Input Resolution (steps per revolution) to **any whole number value greater than or equal to 200**.

INPUT RESOLUTION USE CASES

Note: The examples and screenshots below are based on an 800 count per revolution ClearPath motor.

- **Case #1. You want one step pulse to command one count of motion (default).** One count per step is the most common Input Resolution setting.

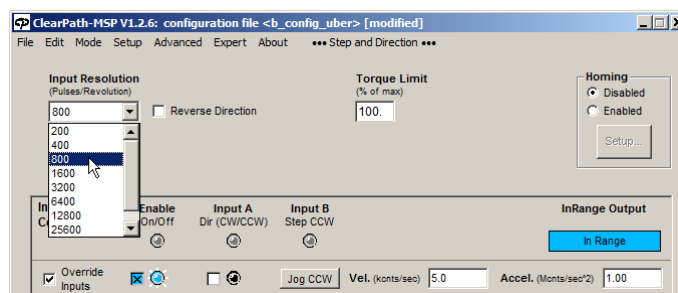

Using the above setting, 800 step pulses will make this [800 count] motor rotate one full revolution.

Tip: To set a 1:1 (1 step = 1 count) relationship, set the Input Resolution to the same value as your motor's Positioning Resolution. Example: For an 800 count per revolution motor (as in the figure above) set Input Resolution to 800 pulses per rev. For a 6400 count per rev motor, set it to 6400 pulses per revolution.

- Case #2. You want one step pulse to command multiple counts of motion.** ClearPath can be configured such that a single step pulse commands 2, 4, 8, or more counts of motion. This strategy is most often used to compensate for a "slow" controller, i.e., a controller that can't put out step pulses fast enough to meet the user's velocity requirements.

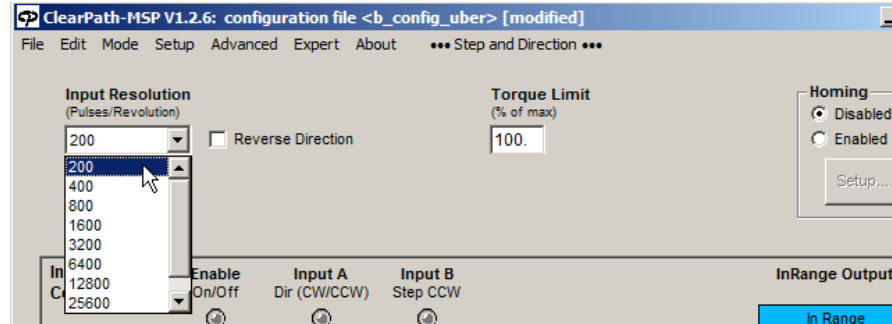

With the above Input Resolution setting, it takes only 200 step pulses to make this [800 count] motor rotate one full revolution.

- Case #3. You need multiple step pulses to command one count of motion.** This use case is less typical, but can be convenient if you happen to be replacing a stepper motor with a ClearPath, but the two motors have different positioning resolutions.

In the below example, by selecting 3200 step pulses per revolution, the controller must send 4 step pulses to command a single count of motion, 8 steps to command two counts of motion, and so forth.

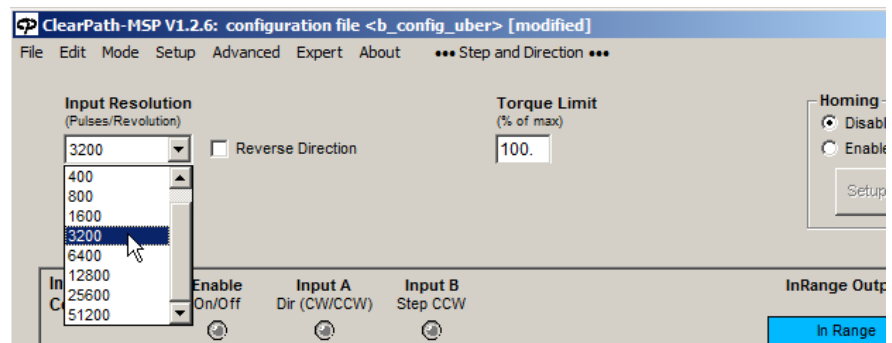

With the above Input Resolution setting, it takes 3200 step pulses to make this [800 count per rev.] motor rotate one full revolution.

RAS AND G-STOP (VIBRATION AND RESONANCE SUPPRESSION)

RAS (Regressive Auto-Spline) and g-Stop are Teknic's proprietary vibration and resonance suppression features. Although these features work somewhat differently, both were designed to help produce smooth motion, reduce machine vibration, audible noise and settling time.

Important Notes:

- RAS and g-Stop cannot be used simultaneously.
- g-Stop is available on all MCPV models with part numbers ending in -Exx (Enhanced).
- g-Stop is not available on SD (Step & Direction) models or MCVC models.

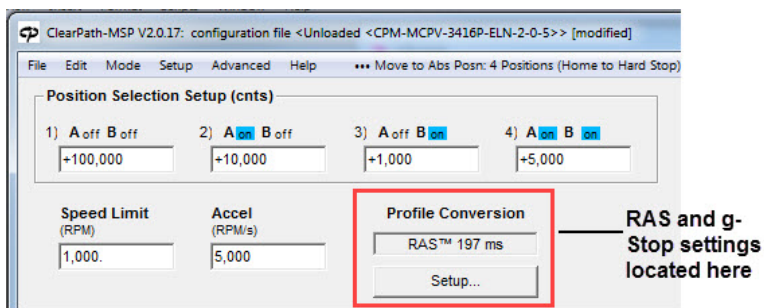

Location of RAS and g-Stop settings

RAS (REGRESSIVE AUTO-SPLINE)

RAS is a jerk limiting, and jerk-derivative limiting feature based on proprietary technology developed by Teknic.

The RAS software uses advanced algorithms to analyze each commanded move and rapidly calculate and "fit" a fourth-order polynomial spline to it. This converts the sharp transitions between constant velocity and acceleration with more gradual, rounded corners. This results in moves that are lower in vibration, quieter, and easier on the machine's mechanical parts.

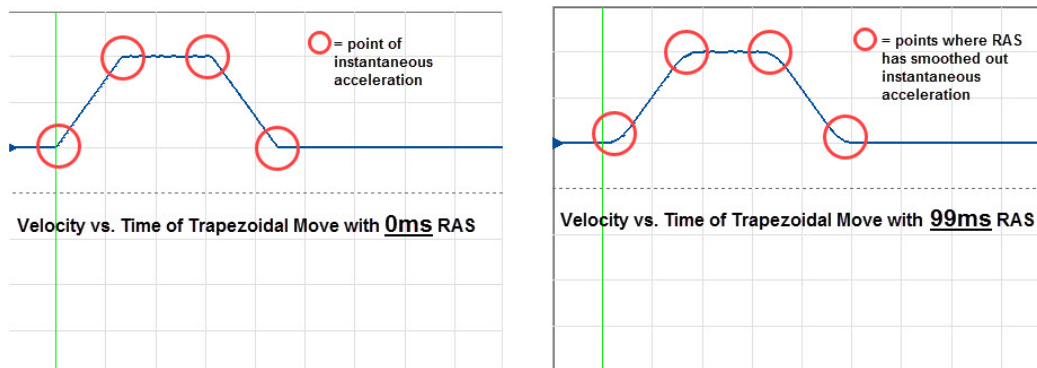

RAS Settings Comparison

Although RAS adds some time to the move (in the millisecond range), it can actually reduce overall move time by reducing settling time and/or allowing for the use of higher acceleration limits.

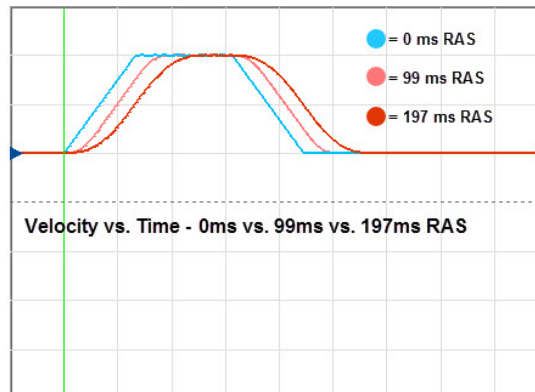

RAS Motion Profile Comparisons

AUTO-RAS (MC SERIES MOTORS)

Auto-RAS simplifies RAS selection by offering three settings, "Auto-High", "Auto-Med", or "Auto-Low". "Auto-High" applies the most jerk/jerk-derivative limiting, but also adds the most conversion time.

Each Auto-RAS setting you choose, automatically adjusts to the motor's velocity and acceleration settings.

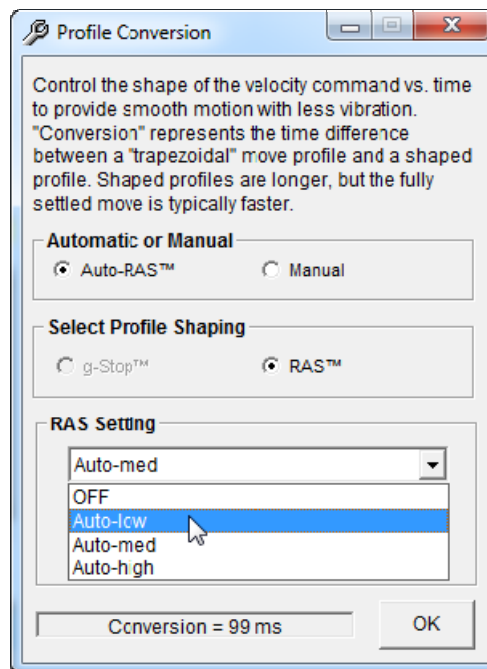

MANUAL RAS SETTINGS (MC AND SD MOTORS)

In MC and SD ClearPath op modes, you can manually select a single numerical RAS setting from the drop down list as shown below.

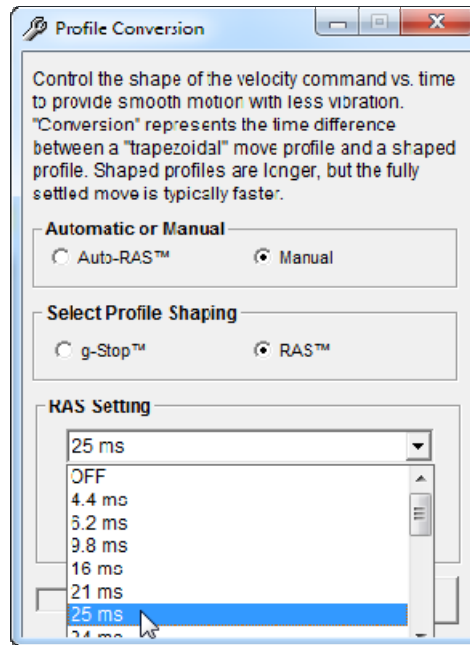

Additional Notes

- Manual RAS settings add a fixed conversion time to all moves. For example, a RAS setting of 25ms will add 25ms of conversion time to all moves issued while Manual RAS is in effect.
- ClearPath SD motors with part numbers ending in -Rxx have limited Manual RAS selections.
- ClearPath MC motors offer Manual RAS settings in increments from 0-779ms.
- Auto-RAS is only available for ClearPath MC series motors.

G-STOP TUNING

Notes:

- g-Stop is available on MCPV models ending in -Exx (Enhanced models). g-Stop is *not* available on MCVC models.
- g-Stop is *not* available on SD (Step & Direction) models.

g-Stop was designed to help address machine resonances, reduce machine shake and vibration, allow for the use of higher acceleration limits, and reduce audible noise. This feature builds on patented technology developed by Teknic.

Teknic Video: g-Stop

To understand how g-Stop works, watch the Teknic video on this topic [here](#). Note: This video was created for the *ClearPath-SC* family of motors, so the UI shown in the video is slightly different from that of MSP.

g-Stop works by analyzing and identifying problematic machine resonances, and then converting the commanded move profile such that energy is intelligently added or removed from the system to cancel the vibrations.

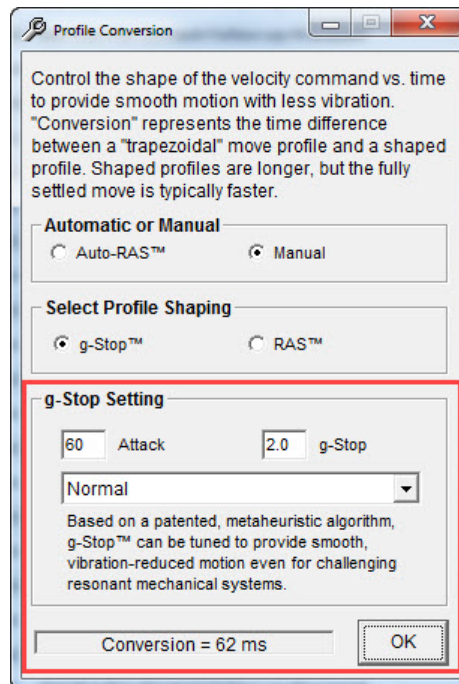

g-Stop Settings; MCPV -Exx (Enhanced) models only

To implement g-Stop, start with a tuned motor that is attached to the mechanical system on which it will be running. Create a test move that is aggressive but realistic. Use the highest acceleration and velocity that the axis or machine is expected to run at. The load must be moving back and forth during the g-Stop tuning process, so always use a repeating (back and forth) type move. MSP's Move Generator can do this type of move.

With the repeating test move running, slowly increase the Attack setting—one increment at a time—while observing axis performance, preferably on an accelerometer, but by observation if necessary. *Tip: Use your keyboard's Page Up and Page Down keys to increment and decrement Attack and g-Stop settings.)*

Increase Attack until the machine vibration has improved to the desired level of performance. Then, slowly increment the g-Stop value to fine tune performance. The objective is to find a solution that results in minimal machine shake and vibration and optimal move and settle time.

OTHER PRODUCT NOTES

CLEARPATH EMC INSTRUCTIONS

<https://tekninc.com/files/downloads/ClearPath EMC Instructions.pdf>

APPENDIX I: LOGIC POWER SUPPLY SIZING

This section was designed to help users estimate how much power (wattage) to specify when selecting a logic power supply for a ClearPath system. The logic supply is typically 24VDC (nominal).

The worksheet below lists the power rating of ClearPath "logic power" system components. Space is provided for calculation of total estimated power usage for any combination of these components.

- Additional Notes**
- Your ClearPath system may not include all of the components listed below.
 - The topic of main DC bus power is not discussed in this section.

Part	Power Req'd (ea)	x	Qty	=	Line Total (Watts)
Logic power backup: <i>integral</i> hp ClearPath motors (optional)	5W	x		=	
Logic power backup: <i>fractional</i> hp ClearPath motors (optional, and requires POWER4-HUB accessory)	3W	x		=	
POWER4-HUB (for fractional hp motors only, optional)	2W	x		=	
Brake/GPO (optional)	W	x		=	
Input Sensors (optional)	W	x		=	
Other	W	x		=	
Grand Total (W)					

Teknic, Incorporated
7650 Omnitech Pl
Victor, NY 14564

© 2026 Teknic Incorporated