



## Gearbox Mounting Instructions

Rev.1.5 1/5/2026

### Gearbox Shaft Key Removal (if required):

**Note:** All gearboxes are shipped with a shaft key installed for compatibility with specific unidirectional motion setups. For the majority of applications, especially those involving dynamic bi-directional motion, it is not recommended to use shaft keys, so you'll want to remove the key before installing the gearbox/motor assembly into your machine. For more information on why shaft keys are not recommended, and alternative solutions, see Teknic's motion article: [Securing Mechanics to Motor Shafts](#).

1. Clamp the gearbox down so that it is securely fixed in place. Orient the gearbox shaft so the shaft key is facing up.
2. Use a pair of diagonal cutting pliers or a parallel key extractor to remove the key. Here's a short video demonstrating how to remove the key using diagonal cutters: [https://youtube.com/shorts/L\\_N\\_Bpb185g?feature=share](https://youtube.com/shorts/L_N_Bpb185g?feature=share)

### Gearbox/Motor Mounting Instructions:

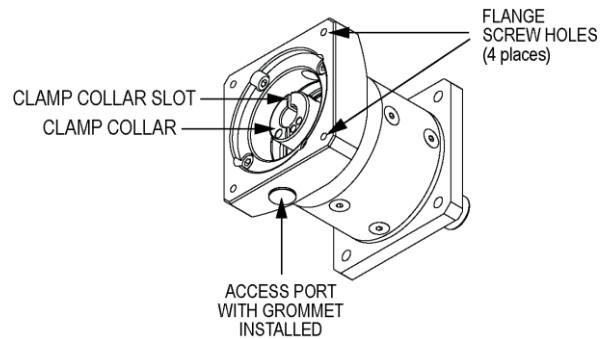

1. Prior to motor installation, remove the Access Port Grommet on the body of the gearbox and rotate the gearbox Clamp Collar such that the clamping screw aligns with the Access Port. This ensures access to the screw for tightening after the motor is mounted.
2. If the gearbox includes a bore adapter, loosen the clamp collar screw and orient the bore adapter slot such that it is rotated approximately 90° with respect to the clamp collar slot.
3. Orient the gearbox vertically so the gearbox shaft faces directly down. It may be helpful to clamp the gearbox flange in a vice. Be sure the mounting faces are free of debris.
4. Slide the motor shaft into the clamp collar and bring the units together until the gearbox and motor flange faces are flush.

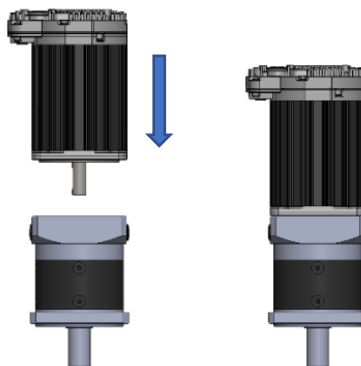

5. Align the flanges and loosely install the four flange screws. Only tighten until resistance is first felt. **Note: Do not fully tighten these screws yet.**
6. Re-orient the assembly such that the gearbox shaft faces directly up. It may be helpful to clamp the motor flange in a vice.

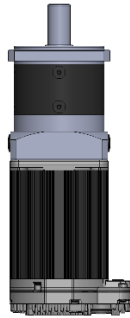

7. While pressing down on the top of the assembly with approximately 10-20 pounds of force, fully tighten the clamp collar screw through the Access Port on the gearbox.
8. Slowly spin the gearbox output shaft one full revolution to ensure the assembly is centered. If the reduction ratio of the gearbox is such that it doesn't allow rotating the shaft by hand, you can power the motor and jog it slowly using the Motion Generator feature in the ClearPath application software.
9. Using a diagonal tightening pattern, fully tighten the four flange screws. Then, repeat this tightening pattern a second time to ensure all screws are fully seated.
10. Loosen the gearbox clamp collar screw until the motor shaft releases. Slight movement may be felt as bearing stress is relieved; this is normal.
11. Fully re-tighten the clamp coupling screw and replace the Access Port Grommet.